

**Instruction 51-1262**  
**06-24-14**

**S&S<sup>®</sup> Cycle, Inc.**

**14025 Cty Hwy G PO Box 215**  
**Viola, Wisconsin 54664**

Phone: 608-627-1497 • Fax: 608-627-1488  
Technical Service Phone: 608-627-TECH (8324)  
Technical Service Email: [sstech@sscyle.com](mailto:sstech@sscyle.com)  
Website: [www.sscyle.com](http://www.sscyle.com)



Copyright © 2006, 2008, 2009,  
2010, 2013, 2014  
by S&S Cycle, Inc.

All rights reserved.  
Printed in the U.S.A.

## Installation Instructions for Single Bore Tuned Induction System

### DISCLAIMER:

S&S parts are designed for high performance, closed course, racing applications and are intended for the very experienced rider only. The installation of S&S parts may void or adversely effect your factory warranty. In addition such installation and use may violate certain federal, state, and local laws, rules and ordinances as well as other laws when used on motor vehicles used on public highways, especially in states where pollution laws may apply. Always check federal, state, and local laws before modifying your motorcycle. It is the sole and exclusive responsibility of the user to determine the suitability of the product for his or her use, and the user shall assume all legal, personal injury risk and liability and all other obligations, duties, and risks associated therewith.

The words Harley®, Harley-Davidson®, H-D®, Sportster®, Evolution®, and all H-D part numbers and model designations are used in reference only. S&S Cycle is not associated with Harley-Davidson, Inc.

### SAFE INSTALLATION AND OPERATION RULES:

Before installing your new S&S part it is your responsibility to read and follow the installation and maintenance procedures in these instructions and follow the basic rules below for your personal safety.

- Gasoline is extremely flammable and explosive under certain conditions and toxic when breathed. Do not smoke. Perform installation in a well ventilated area away from open flames or sparks.
- If motorcycle has been running, wait until engine and exhaust pipes have cooled down to avoid getting burned before performing any installation steps.
- Before performing any installation steps disconnect battery to eliminate potential sparks and inadvertent engagement of starter while working on electrical components.
- Read instructions thoroughly and carefully so all procedures are completely understood before performing any installation steps. Contact S&S with any questions you may have if any steps are unclear or any abnormalities occur during installation or operation of motorcycle with a S&S part on it.
- Consult an appropriate service manual for your motorcycle for correct disassembly and reassembly procedures for any parts that need to be removed to facilitate installation.
- Use good judgment when performing installation and operating motorcycle. Good judgment begins with a clear head. Don't let alcohol, drugs or fatigue impair your judgment. Start installation when you are fresh.
- Be sure all federal, state and local laws are obeyed with the installation.
- For optimum performance and safety and to minimize potential damage to carb or other components, use all mounting hardware that is provided and follow all installation instructions.
- Motorcycle exhaust fumes are toxic and poisonous and must not be breathed. Run motorcycle in a well ventilated area where fumes can dissipate.

### IMPORTANT NOTICE:

Statements in this instruction sheet preceded by the following words are of special significance.

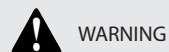

**WARNING**

Means there is the possibility of injury to yourself or others.



**CAUTION**

Means there is the possibility of damage to the part or motorcycle.

**NOTE**

Other information of particular importance has been placed in italic type.

S&S recommends you take special notice of these items.

### WARRANTY:

All S&S parts are guaranteed to the original purchaser to be free of manufacturing defects in materials and workmanship for a period of twelve (12) months from the date of purchase. Merchandise that fails to conform to these conditions will be repaired or replaced at S&S' option if the parts are returned to us by the purchaser within the 12 month warranty period or within 10 days thereafter.

In the event warranty service is required, the original purchaser must call or write S&S immediately with the problem. Some problems can be rectified by a telephone call and need no further course of action.

A part that is suspect of being defective must not be replaced by a Dealer without prior authorization from S&S. If it is deemed necessary for S&S to make an evaluation to determine whether the part was defective, a return authorization number must be obtained from S&S. The parts must be packaged properly so as to not cause further damage and be returned prepaid to S&S with a copy of the original invoice of purchase and a detailed letter outlining the nature of the problem, how the part was used and the circumstances at the time of failure. If after an evaluation has been made by S&S and the part was found to be defective, repair, replacement or refund will be granted.

### ADDITIONAL WARRANTY PROVISIONS:

- (1) S&S shall have no obligation in the event an S&S part is modified by any other person or organization.
- (2) S&S shall have no obligation if an S&S part becomes defective in whole or in part as a result of improper installation, improper maintenance, improper use, abnormal operation, or any other misuse or mistreatment of the S&S part.
- (3) S&S shall not be liable for any consequential or incidental damages resulting from the failure of an S&S part, the breach of any warranties, the failure to deliver, delay in delivery, delivery in non-conforming condition, or for any other breach of contract or duty between S&S and a customer.
- (4) S&S parts are designed exclusively for use in Harley-Davidson® and other American v-twin motorcycles. S&S shall have no warranty or liability obligation if an S&S part is used in any other application.

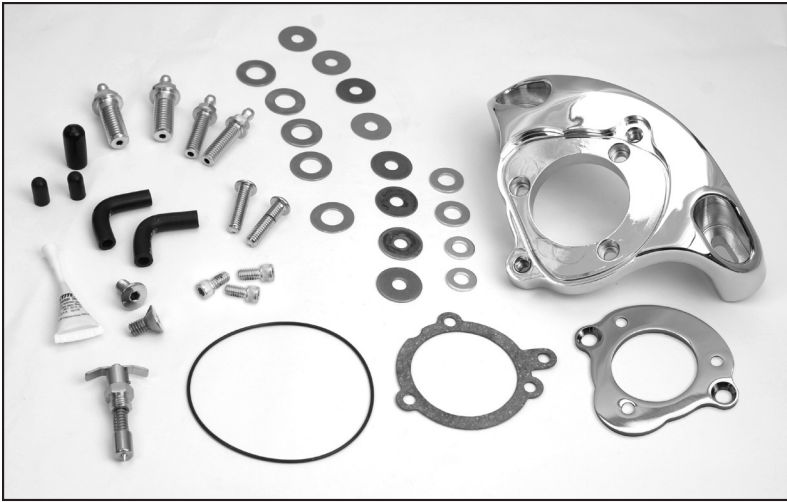

Bracket kit for single bore tuned induction system- hardware contents and bracket styles may vary.



Single bore tuned intake kit available in natural, wrinkle black or chrome plated finishes. Filters available in red or blue.

### INSTALLATION



**Installation of the Teardrop Air Cleaner on carbureted motorcycles is limited to closed course competition use only.**

**NOTE:** The Teardrop Air Cleaner may be used on 2001 and later fuel injected highway motorcycles.

- 1- Remove the existing air cleaner and clean the carburetor or throttle body face and the cylinder head mount faces. These surfaces must be free of any burrs or remaining gasket material, which could prevent a proper seal or fit. **See Picture 1, below.**



Picture 1

- 2- For S&S® Super E or G carburetors, remove the existing enrichment device and install the supplied S&S quarter-turn enrichment device. **See Picture 2, below.**
- 3- Locate the bracket, three ¼" - 20 x ½" socket head cap screws, gasket\* and shims from the bracket kit.



Picture 2

**NOTE:** A gasket is supplied for the S&S Throttle Body or E & G Carburetor. The gasket for stock Harley-Davidson® motorcycle applications is also supplied. Select the appropriate gasket.

Some brackets have a secondary breather passage that must be connected to a breather system or capped. **See Picture 3.**

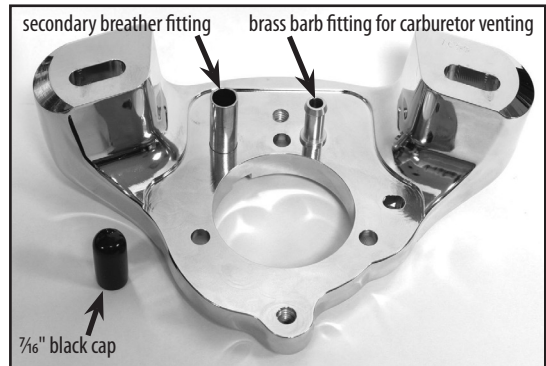

Picture 3

For S&S 4 1/8" V-Series carbureted engines, locate the breather hose attached to the rear cylinder head and connect it to the secondary breather hose fitting. **See Picture 4, below.**



Picture 4



If the secondary breather passage is not used, cap it with the supplied  $\frac{7}{16}$ " black cap. **See Picture 3.**

Brackets for S&S Super E & G carburetors will have a brass barb fitting on the back of the bracket. **See Picture 3.** Attach the supplied rubber tubing to the brass barb fitting. **See Picture 4.** Route the hose under the gas tank or in an area of undisturbed air. Make sure the hose points down and towards the rear of the motorcycle to prevent water from entering. Make sure the hose does not kink.

- 4- Measure and record the bracket standoff thickness using a caliper against a flat surface. If a caliper is not available then skip this step and go to the next. **See Picture 5, below.**



**Picture 5**

- 5- Fasten the bracket and gasket to the carburetor or throttle body face using the three supplied  $\frac{1}{4}$ " - 20 x  $\frac{1}{2}$ " socket head cap screws (torque to 90-110 in-lbs). There are two gaskets included in some kits. One for S&S carbs and one for stock carbs or throttle bodies. Verify that the threads of the screws have pre-applied threadlock.

**NOTE:** The gasket must be positioned evenly around the S&S® Super E or G carburetor bore. If the gasket is too low then it may not seal at the bottom of the bore and poor performance may result. **See Picture 6, below .**

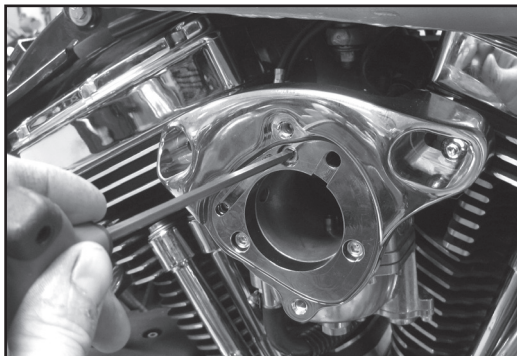

**Picture 6**

- 6- The slots of the bracket standoffs must be aligned with the cylinder head mounts. If the bracket is not aligned then determine if there is enough intake manifold flexibility to position the bracket correctly. If there is not enough flexibility then loosen the intake manifold and adjust accordingly. **See Picture 7.**

**NOTE:** Make certain the intake manifold is fastened tightly before continuing.

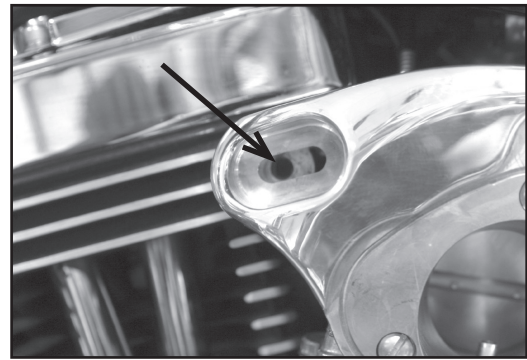

**Picture 7**

- 7- Measure and record the distance from the bracket standoff outer face to the cylinder head mount face using a caliper. Calculate the required shim thickness (shim thickness = bracket-to-head distance - bracket standoff thickness) and select the shims that are equal to, or no less than 0.020" of the calculated shim thickness. If a caliper is not available then select and test different sized shims. An assortment of shim thicknesses are supplied with each bracket kit. Combine the appropriate shims to fill the gap between the bracket and the cylinder head mount surface. **See Picture 8.**

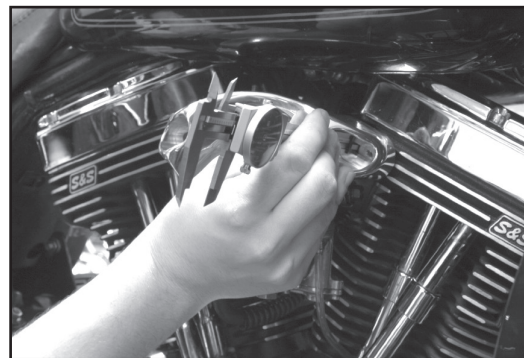

**Picture 8**

**CAUTION**

**If the shims used are too thick or not thick enough then damage to the intake manifold and the carburetor or throttle body may result. This can potentially cause leaks in the system.**

- 8- Choose the supplied bracket mounting fasteners and washers that fit your cylinder head mounts. The choices are  $\frac{5}{16}$ " - 18 x 1- $\frac{1}{4}$ " button head cap screws,  $\frac{3}{8}$ " - 16 x 1- $\frac{1}{4}$ " breather screws or  $\frac{1}{2}$ " - 13 x 1- $\frac{1}{4}$ " breather screws. Use the appropriate supplied washers for the  $\frac{5}{16}$ " and  $\frac{3}{8}$ " screws. Apply a drop of blue threadlock to the selected screws. Install the screws while supporting the shims and torque to 15 ft-lbs. **See Picture 9.**



**Picture 9**

- 9- If the breather screws are used then the supplied breather hoses are needed. The breather hose has a 90-degree bend with one end longer than the other. Insert the longer end onto the barb fitting of the breather screw. Insert the shorter end onto the barb fitting of the bracket. The breather hose may need to be trimmed to fit on some applications. **See Picture 10.**



**Picture 10**

- 10- If the button head cap screws are used then the supplied 1/4" black caps are needed. Insert the black caps onto the barb fittings of the bracket. These caps prevent contaminants from entering the air flow to the engine. **See Picture 11.**

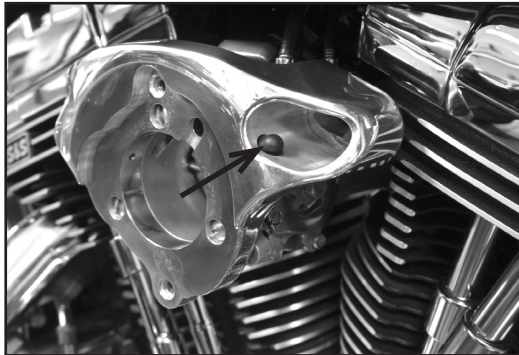

**Picture 11**

- 11- Install the supplied O-Ring into the O-Ring groove on the face of the bracket. The O-Ring may need to be stretched or compressed to fit in the O-Ring groove. The O-Ring will increase in size when heated above room temperature. **See Picture 12.**

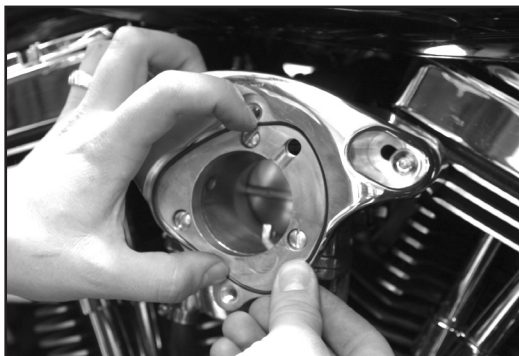

**Picture 12**

**NOTE:** If the O-Ring is removed from a hot engine then the O-Ring may need to cool before reinstalling it.

12. Locate the single bore tuned intake assembly, two 5/16" – 18 x 5/8" flat head socket cap screws and the two air filters with clamps. Apply a drop of blue threadlock to the screws. Verify that the O-Ring stays in the O-Ring groove. Align the single bore tuned intake assembly and torque the screws to 15 ft-lbs. **See Picture 13.**

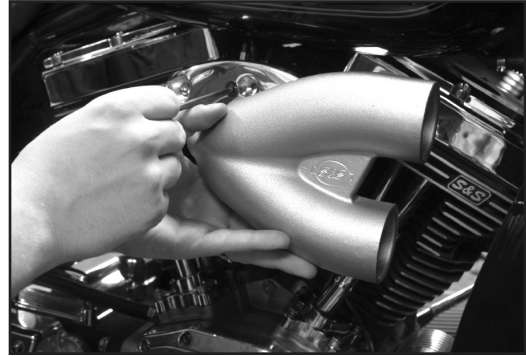

**Picture 13**

13. Install the air filters and clamps onto the single bore tuned intake assembly. Press the air filters on approximately 1-inch from the tube ends. Tighten the clamps towards the end of the air filter flange. **See Picture 14.**

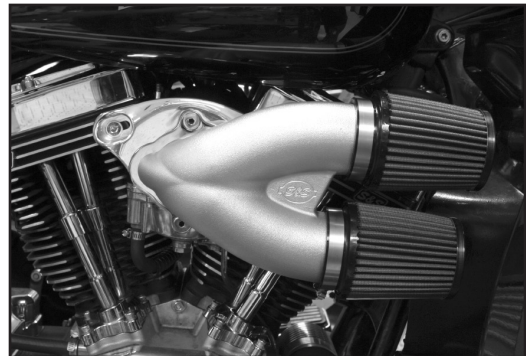

**Picture 14**

**NOTE:** If the motorcycle is equipped with faring lowers then it may be necessary to remove the glove-box from the faring lowers. **See Picture 15.**



**Picture 15**

15. On 2001 and later fuel injected bikes apply the included label containing the EO number to the frame down tube above or below the factory label. Do not cover up any portion of the factory label.



Picture 16

**⚠ WARNING ⚠**

**Do not apply this label to carbureted motorcycles.**



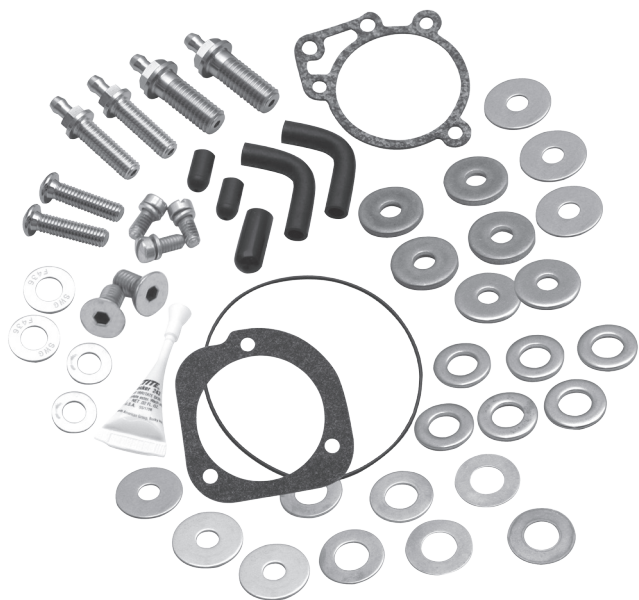

**17-5098**

1984-up BT

- S&S single-bore EFI
- Stock carb
- 2001-up Delphi EFI

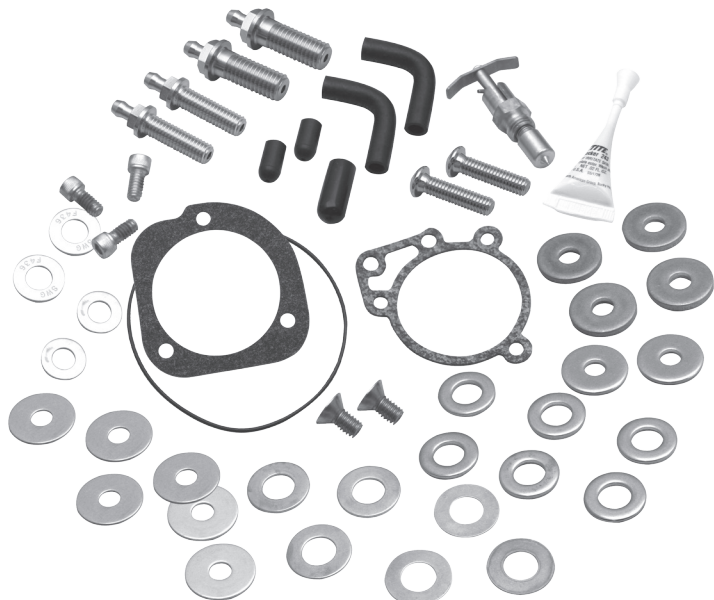

**17-5099**

1984-up BT & 1986-'03 XL

- S&S Super E & G



**106-1066**

X-Wedge

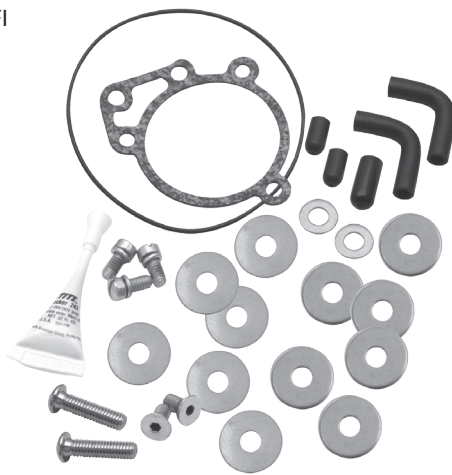

**500-0016**

S&S 124 V-Series or T-Series

- Single-bore EFI
- E & G carb



**500-0018**

1991-up XL

- Stock carb
- 2004-up EFI

# S&S® SINGLE BORE EFI TUNED INDUCTION SYSTEM REPLACEMENT PARTS

1. Tuned Intake Kit, 2.19" Single Bore
  - Natural ..... 106-4968
  - Wrinkle Black ..... 106-4969
  - Chrome Plated ..... 106-4970
2. Tuned Intake Assembly, 2.19" Single Bore
  - Natural ..... 106-4965
  - Wrinkle Black ..... 106-4966
  - Chrome Plated ..... 106-4967
3. Air Filter, with Clamp
  - Stainless Cap – Conical – 2 $\frac{1}{16}$ " I.D. x 4"
  - Red (1 Each)..... 17-1020
  - Blue (1 Each) ..... 17-1023
4. Gasket, Intake – Adapter Plate
  - 2.19" Single Bore Tuned Intake..... 17-1022
5. Plate, Adapter, 2.19" Single Bore Tuned Intake
  - Chrome Steel..... 17-1014
6. FHSC ¼-20 x 5/8" ..... 50-0433
7. FHSC 5/16-18 x 5/8" ..... 50-0432
8. O-Ring, Adapter Plate Bracket
  - 3 $\frac{3}{8}$ " O.D. x 3 $\frac{1}{2}$ " I.D. ¼ CS, Viton..... 50-0446
9. Bracket Kit, 2.19" Single Bore Tuned Intake
  - Super E/G, S&S V124 & T124 - Chromed ..... 106-4973
  - Super E/G, 1984-up BT - Chromed..... 106-4974
  - Super E/G, 1986-'03 Sportster® - Chromed..... 106-4975
  - Single VFI, S&S V124 & T124 - Chromed..... 106-4976
  - Single VFI, 1984-up BT - Chromed ..... 106-4977
  - Stock carb, Delphi® EFI, 1984-up BT - Chromed..... 106-4978
  - S&S X-Wedge™ ..... 106-4972
  - Stock CV & EFI, 1991-up XL..... 106-6026
10. Backplate Screw
  - Screw, SHC, w/Threadlock, ¼-20 x ½" ..... 106-2084
  - LSHC Black Oxide (X-Wedge Only)..... 106-0817
11. Screw, 5/16 - 18 x 1¼, BHC, Chrome ..... 50-0309-5
12. Flat Washer 5/16" x 1/16" ..... 50-7034
13. Hose, Breather, ¼" I.D., 90° ..... 19-0178
14. Screw, Breather Fitting, 3/8 - 16 x 1¼" ..... 50-0436
15. Washer, Flat, 3/8" x 13/16" x 1/16", Chrome..... 50-7106-5
16. Screw, Breather Fitting, ½ - 13 x 1.25 ..... 50-0435
17. Shim Kit
  - (a) 5/16" I.D. 1984-'92 BT  
1986-'90 XL models and S&S 4 $\frac{1}{16}$ " engines ..... 17-0314
  - (b) ½" I.D. 1993-up BT, 1991-up XL models ..... 17-0464
18. Enrichment Device, S&S Super E & G carbs
  - (Use in place of enrichment device on air cleaner backplate)
  - ..... 11-2084
19. Gasket, Backplate - E/G/SBEFI..... 106-1724
20. Gasket, S&S SBEFI 58mm..... 106-4662
21. Gasket, Stock carb/Throttle Body..... 106-6022

## ADAPTER BRACKET KITS FOR SINGLE BORE TUNED INDUCTION SYSTEMS

Engine/Model	Fuel System			
	Super E or G Carburetor	S&S Single Bore EFI	Stock Carburetor	2001-up Delphi® EFI
S&S X-Wedge™	N/A	106-4972	N/A	N/A
S&S V124 S&S T124	106-4973	106-4976	NA	NA
1999-up Big Twin	106-4974	106-4977	106-4978	106-4978
1984-'99 Big Twin	106-4974	106-4977	106-4978	NA
2004-up Sportster®	106-6026	NA*	106-6026	106-6026
1991-'03 Sportster	106-4975	NA*	106-6026	NA
1986-'90 Sportster	106-4975	NA*	NA	NA

\*NOTE – S&S Single bore EFI is not available for Harley-Davidson® Sportster® models.

