

400 W. Artesia Blvd.
Compton, CA 90220
Fax: (310) 747-3912
Ph: 1-800-776-0767
E-Mail: info@procompusa.com
Website: www.procompusa.com

Latest Revision:
9.27.2014



off-road driven!™

PRO COMP SUSPENSION

52219B/52219BP
K4144B/K4144BP
2009 -2014 FORD F150 2WD 4" LIFT KIT

NOTE: This kit fits 2011-2014 vehicles equipped with electric steering rack

***IMPORTANT!: 18" AND LARGER WHEEL, NOT TO EXCEED
9" IN WIDTH WITH A MAXIMUM BACKSPACING OF 5 1/2"
MUST BE USED IN CONJUNCTION WITH THIS LIFT KIT!
EXCLUDES 18" REVERSE MOUNT WHEELS.***

See pg. 5 for details.

This document contains very important information that includes warranty information and instructions for resolving problems you may encounter. Please keep it in the vehicle as a permanent record.

Box 1 of 4-PN 52219B-1

Part #	Description	Qty.	Illus.	Page
91-5559	REAR CROSSMEMBER	1	3,4	7
91-5565	SWAY BAR DROP: Drvr	1	4	7
91-5574	REAR BUMP STOP DROP	4	12	14
91-5575	STRUT SPACER SHIM	2	7b	9
90-6701	HARDWARE PACK: Rear Crossmember	2	-	-
71-181502501000	18mm-2.5 X 150mm HEX BOLT 10.9	1	5	8
72-01810932	18mm-2.5 STOVER NUT Gr. C	1	5	8
73-01810934	18mm USS FLAT WASHER	2	5	8
90-6703	HARDWARE PACK: Leaf Spring Shim Pack	1	-	-
90-3085	FORD REAR END SHIMS	4	-	-
97-120	1/2" X 3 1/2" GR. 8 USS. HEX MACHINED HEAD	4	-	-
72-050100811	1/2" GR. 8 USS UNPLATED HEX NUT	4	-	-
90-6314	HARDWARE PACK: Rear Bump stop Drops	1	-	-
70-0311001800	5/16" X 1 HEX BOLT GR. 8 -Not Used	1	-	-
72-031100816	5/16" STOVER NUT GR. C -Not Used	1	-	-
73-03100838	5/16" USS FLAT WASHER -Not Used	2	-	-
70-0371501800	3/8" X 1 1/2" HEX BOLT GR. 8	2	12	15
72-037100816	3/8" STOVER NUT GR. C	2	12	15
73-03700034	3/8" HARDENED FLAT WASHER	4	12	15
90-6569	HARDWARE PACK: Carrier Bearing Shim Kit	1	-	-
90-1080	3/8" SHIM	2	-	-
90-1081	1/4" SHIM	2	-	-
90-1082	1/8" SHIM	2	-	-
90-6013	HARDWARE PACK: Carrier Bearing Shim Kit	1	-	-
70-04322501800	7/16" x 2 1/4" USS GRADE 8 BOLT	2	-	-
73-04300042	7/16 USS HARDENED WASHER	2	-	-
95-204F	2" LIFT BLOCK	2	11	14
31-40024	SPRING RETAINER COLLAR	4	7	9
61-40025	SPRING COLLAR	4	7	9
P-1381	LOWER SPRING PERCH	4	7	9
90-40027	STRUT BUMPSTOP DROP	4	7	9
13-90385	U-BOLT: 9/16"-18 x 3.75" x 10.50"	4	11	14

Box 2 of 4-PN 52213B-2

90-4253	KUCKLE: Drvr	1	-	-
90-4254	KUCKLE: Pass	1	-	-
91-7210	BRAKE LINE BRACKET: Front Knuckle	2	-	-
90-6299	HARDWARE PACK: Front Brake Lines	1	-	-
70-0311001500	5/16" X 1" Gr. 5 HEX BOLT	2	-	-
72-03100100512	5/16" NYLOCK NUT	2	-	-
73-03100030	5/16" SAE FLAT WASHER	4	-	-
90-6736	HARDWARE PACK: Caliper Mount	1	-	-
62NWHDY/SAEXT	5/8" (thick) Hardened Flat Washer	4	-	-

Box 3 of 4-PN 52213B-3

Part #	Description	Qty.	Illus.	Page
91-5519	FRONT CROSSMEMBER	1	2	7
91-5518	SWAY BAR DROP: Pass	1	4,6	7,8
91-2126	COMPRESSION STRUT	2	9	10
13-90390	U-BOLT: 9/16"-18 x 3.36" x 12.50" - Not Used	4	11	14
91-7826	EMERGENCY BRAKE BRACKET	1	10	13
91-1435	COMPRESSION STRUT MOUNT	2	9	10
91-5502	REAR BRAKE LINE DROP	1	-	-
90-6422	HARDWARE PACK: E-Brake Bracket	1	-	-
70-0501501800	1/2" X 1 1/2 HEX BOLT Gr. 8	1	10	13
73-05000034	1/2" HARDENED FLAT WASHER	2	10	13
72-0501100816	1/2" NYLOCK NUT Gr. 8	1	10	13
90-6314	HARDWARE PACK: Brake Line Drop/ Bump Kit	1	-	-
70-0311001800	5/16" X 1" HEX BOLT Gr. 8 -Not Used	1	-	-
72-031100816	5/16" STOVER NUT Gr. C -Not Used	1	-	-
73-03100832	5/16" USS FLAT WASHER -Not Used	2	-	-
70-0371501800	3/8" X 1 1/2" HEX BOLT Gr.8	2	10	13
72-037100816	3/8" STOVER NUT Gr. C	2	10	13
73-03700034	3/8" HARDENED FLAT WASHER	4	10	13
90-6393	HARDWARE PACK: Front Brake Line Drops	1	-	-
90-3202	F150 BRAKELINE DROP	2	-	-
90-6299	HARDWARE PACK: Front Brake Lines	1	-	-
70-0311001500	5/16" X 1" Gr. 5 HEX BOLT	2	-	-
72-03100100512	5/16" NYLOCK NUT	2	-	-
73-03100030	5/16" SAE FLAT WASHER	4	-	-
90-6315	HARDWARE PACK: Sway Bar Drop	1	-	-
70-0431751800	7/16" X 1 3/4" HEX BOLT Gr. 8	4	4,6	7,8
72-043100816	7/16" STOVER NUT Gr. C	4	4,6	7,8
73-04300830	7/16" SAE FLAT WASHER	8	4,6	7,8
90-6319	HARDWARE PACK: Zip Ties	1	-	-
10999	ZIP TIE, 11", BLACK	12	-	-
90-6700	HARDWARE PACK: Cam Bolts	1	-	-
90-5532	CAM ECCENTRIC: F-150 Slotted	4	5	8
90-5533	CAM BOLT- Front: 18mm-2.5 X 150mm 10.9	2	5	8
90-5535	CAM BOLT- Rear: 18mm-2.5 X 160mm 10.9	2	5	8
90-6313	HARDWARE PACK: Crossmember	1	-	-
72-01810932	18mm STOVER NUT	4	5	8
73-01810934	18mm FLAT WASHER	4	5	8
90-6263	HARDWARE PACK: Compression Strut Bushings	1	-	-
15-11148	URETHANE BUSHING	8	9	10
90-2109	SLEEVE	4	9	10
90-6234	HARDWARE PACK: Compression Struts	1	-	-
70-0501251800	1/2" X 1 1/4" HEX BOLT Gr. 8	2	9	10
70-0504001800	1/2" X 4" HEX BOLT Gr. 8	4	9	10
72-050100816	1/2" STOVER NUT Gr. C	4	9	10
73-05000034	1/2" HARDENED FLAT WASHER	10	9	10

Part #	Description	Qty.	Illus.	Page
90-1915	NUT PLATE: Compression Strut	2	9	10
20-65302	HARDWARE PACK: 9/16" HI-NUTS	1	11	14
Box 4 of 4-PN 52213B-4				
932008	9000 SERIES SHOCK	2	-	-
91-2977	STRUT SPACER	2	8	9
90-6317	HARDWARE PACK: Spacer Mount	1	-	-
72-043200810	7/16" GR. 8 HEX NUT	6	8	9
73-04300830	7/16" SAE FLAT WASHER	6	8	9
73-04300836	7/16" SPLIT LOCK WASHER	6	8	9
Box 4 BP of 4-PN 52213BP-4				
ZX2071	PRO RUNNER MONOTUBE REAR SHOCKS	2	-	-
91-2977	STRUT SPACER	2	8	9
90-6317	HARDWARE PACK: Spacer Mount	1	-	-
72-043200810	7/16" GR. 8 HEX NUT	6	8	9
73-04300830	7/16" SAE FLAT WASHER	6	8	9
73-04300836	7/16" SPLIT LOCK WASHER	6	8	9

Special Tools:

Please refer to your service manual for more information.

A special removal tool is required for safe removal of the tie rods. (PN T64P-3590-F).

These tool may be purchased at your local Ford dealer.

You may be able to rent any of these tools at your local parts store.

Optional Equipment Available from your Pro Comp Distributor!

52213B/52213BMX (2009-2013 only)

PN 52209B/52209BMX

62159

62160

52211BMX*

52214BMX*

Mounting kit: 72096B*, Bars: 72500B*

13137*

2WD 6" Suspension Lift Kit

4WD 6" Suspension Lift Kit

4WD Level Lift Kit

2WD Level Lift Kit

4WD Coil Over Upgrade Kit

2WD Coil Over Upgrade Kit

Traction bars: 4wd Crew cab short bed

Add a leaf kit: (Use with Suspension lift kit)

*Install on Pro Comp lift kit equipped vehicles ONLY!

Also, check out our outstanding selection of Pro Comp tires
compliment your new installation!

Notice:

- ◆ This installation requires a professional mechanic!
- ◆ We recommend that you have access to a factory service manual for your vehicle to assist in the disassembly and reassembly of your vehicle. It contains a wealth of detailed information.
- ◆ Prior to installation, carefully inspect the vehicle's steering and driveline systems paying close attention to the tie rod ends, ball joints, wheel bearing preload, pitman and idler arm. Additionally, check steering-to-frame and suspension-to-frame attaching points for stress cracks. The overall vehicle must be in excellent working condition. Repair or replace all worn or damaged parts!
- ◆ Read the instructions carefully and study the illustrations before attempting installation! You may save yourself a lot of extra work.
- ◆ Check the parts and hardware against the parts list to assure that your kit is complete. Separating parts according to the areas where they will be used and placing the hardware with the brackets before you begin will save installation time.
- ◆ Check the special equipment list and ensure the availability of these tools.
- ◆ Secure and properly block vehicle prior to beginning installation.
- ◆ Always use NEW cotter pins on re-assembly! (These items are NOT supplied)
- ◆ ALWAYS wear safety glasses when using power tools or working under the vehicle!
- ◆ Use caution when cutting is required under the vehicle. The factory undercoating is flammable. Take appropriate precautions. Have a fire extinguisher close at hand.
- ◆ **IT IS ADVISABLE THAT YOU HAVE HELP AVAILABLE WHEN INSTALLING THIS KIT. SOME COMPONENTS ARE HEAVY AND AWKWARD. ADDITIONAL HELP IS GOOD INSURANCE AGAINST INJURY!**
- ◆ Foot pound torque readings are listed on the Torque Specifications chart at the end of the instructions. These are to be used unless specifically directed otherwise. Apply thread lock retaining compound where specified.
- ◆ **Please note that while every effort is made to ensure that the installation of your Pro Comp lift kit is a positive experience, variations in construction and assembly in the vehicle manufacturing process will virtually ensure that some parts may seem difficult to install. Additionally, the current trend in manufacturing of vehicles results in a frame that is highly flexible and may shift slightly on disassembly prior to installation. The use of pry bars and tapered punches for alignment is considered normal and usually does not indicate a faulty product. However, if you are uncertain about some aspect of the installation process, please feel free to call our tech support department at the number listed on the cover page. We do not recommend that you modify the Pro Comp parts in any way as this will void any warranty expressed or implied by the Pro Comp Suspension company.**
- ◆ If you use traction bars, ES9000 shocks may hit the traction bar mount, if it does a MX6 Series shock should be used.

Tire & Wheel Information:

Due to differences in manufacturing, dimensions and inflated measurements, tire and wheel combinations should be test fit prior to installation. Tire and wheel choice is crucial in assuring proper fit, performance, and the safety of your Pro Comp equipped vehicle. For this application, a 18" or larger wheel not to exceed 9" in width with a maximum backspacing of 5 1/2" is acceptable. A quality tire of radial design, not exceeding 35" tall X 13.5" wide is recommended. Please note that the use of a 35" X 13.5" tire may require fender modification. Violation of these recommendations will not be endorsed as acceptable by Pro Comp Suspension and will void any and all warranties either written or implied.

IMPORTANT!: 18" OR LARGER WHEELS MUST BE USED IN CONJUNCTION WITH THIS LIFT KIT! EXCLUDES 18" REVERSE MOUNT WHEELS.

Front Installation:

1. Prior to installing this kit, with the vehicle on the ground. Measure the height of your vehicle. This measurement can be recorded from the center of the wheel, straight up to the top of the inner fender lip. Record the measurements below.

LF: _____ RF: _____

LR: _____ RR: _____

2. Ensure that your work space is of adequate size and the work surface is level. Place the vehicle in park and set parking brake. Place blocks both in front of and behind the rear wheels. Place your floor jack under the front cross member and raise vehicle. Place jack stands under the frame rails behind the front wheel wells and lower the frame onto the stands. Remove the jack and remove the front wheels.
3. Remove any skid plates if necessary.
4. Work on one side of the vehicle at a time.
5. Unbolt the **OE** brake line and bracket from the side of the knuckle. Save the hardware for reinstallation.
6. Remove the front caliper and bracket assembly from the front knuckle by removing the **(2)** retaining bolts.
NOTE: Make sure you do not let the calipers hang on the brake lines or damage will occur.
7. Remove the front rotors from the front hub.
8. Disconnect the sway bar end links from the sway bar. Save hardware for reinstallation.
9. Unbolt and remove the sway bar from the vehicle. Save hardware for reinstallation.
10. Remove the tie rod end nut and separate from the knuckle using the appropriate tool.

11. Remove the upper ball joint nut from the knuckle and separate using the appropriate tool.
12. Remove the lower ball joint nut, separate using the appropriate tool. Remove the knuckle from the vehicle and set the knuckle aside.
13. Remove the three nuts from the top of the coil over assembly and the one large nut and bolt on the bottom. Remove the coil from the vehicle. Save hardware for reinstallation.
14. Remove the two bolts that retain the lower a-arms and remove them from the truck.
15. Repeat on the other side of the vehicle.
16. Remove the rear cross member brace; retain the **(4)** **OE** bolts and nuts for reinstallation. See **Illustration 1**.
NOTE: Careful heating of the OE bolts may be necessary to loosen the factory thread locker.
17. Install the front cross member **(91-5519)** into original front A-arm mounting locations, using the factory bolts with the heads to the front, leave loose. See **II-**

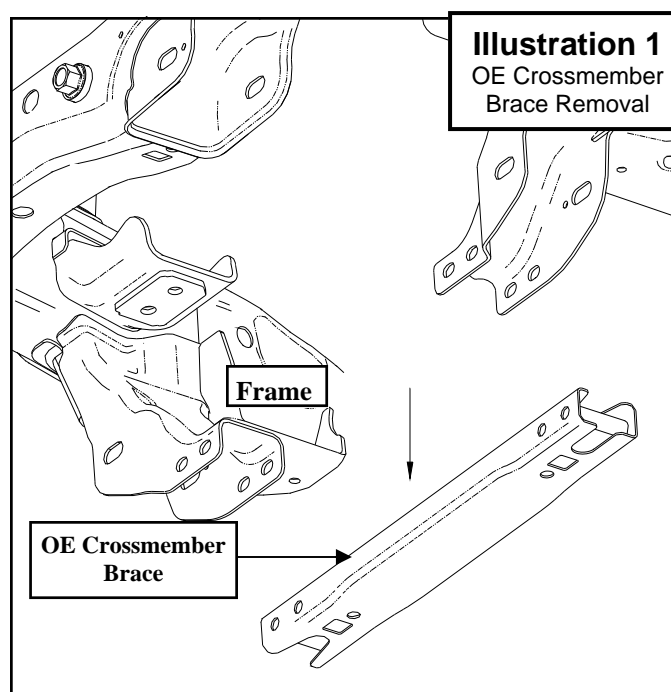

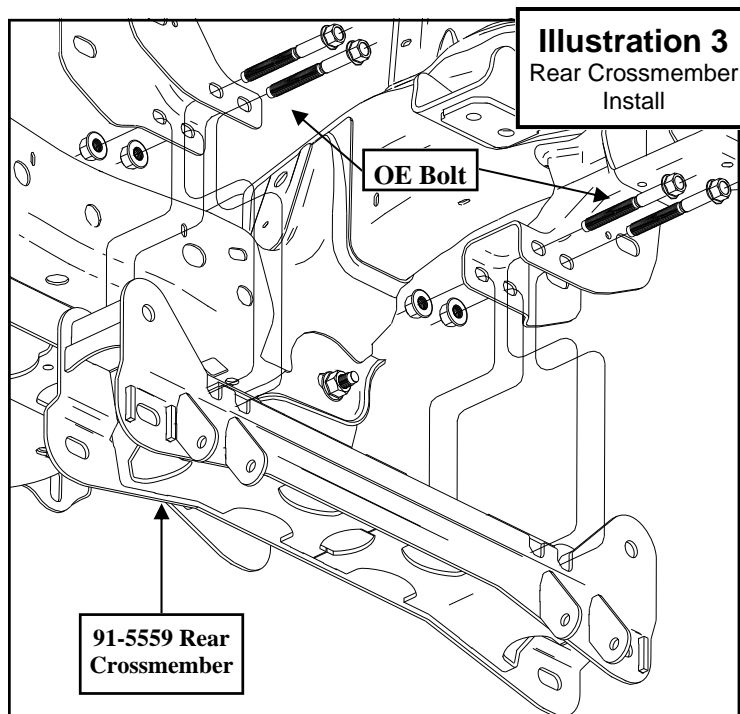
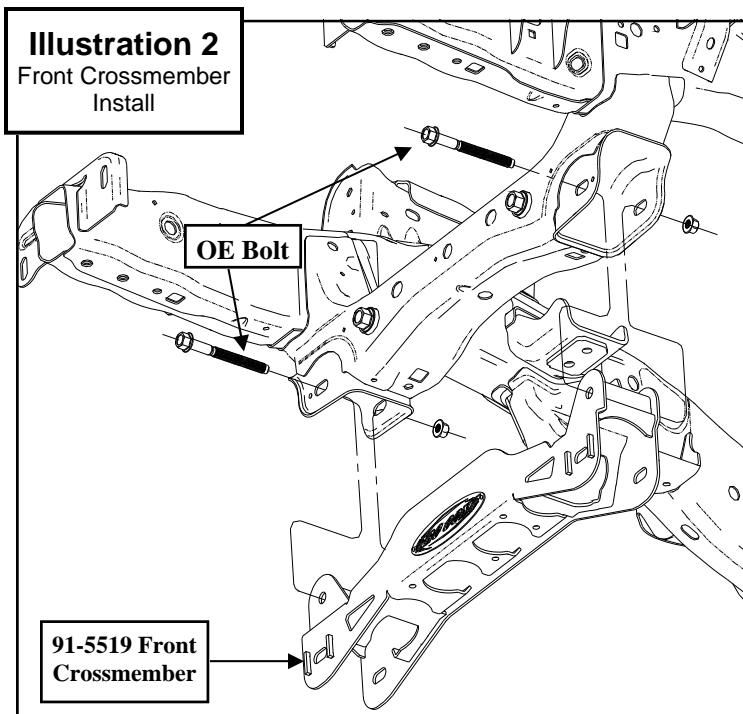
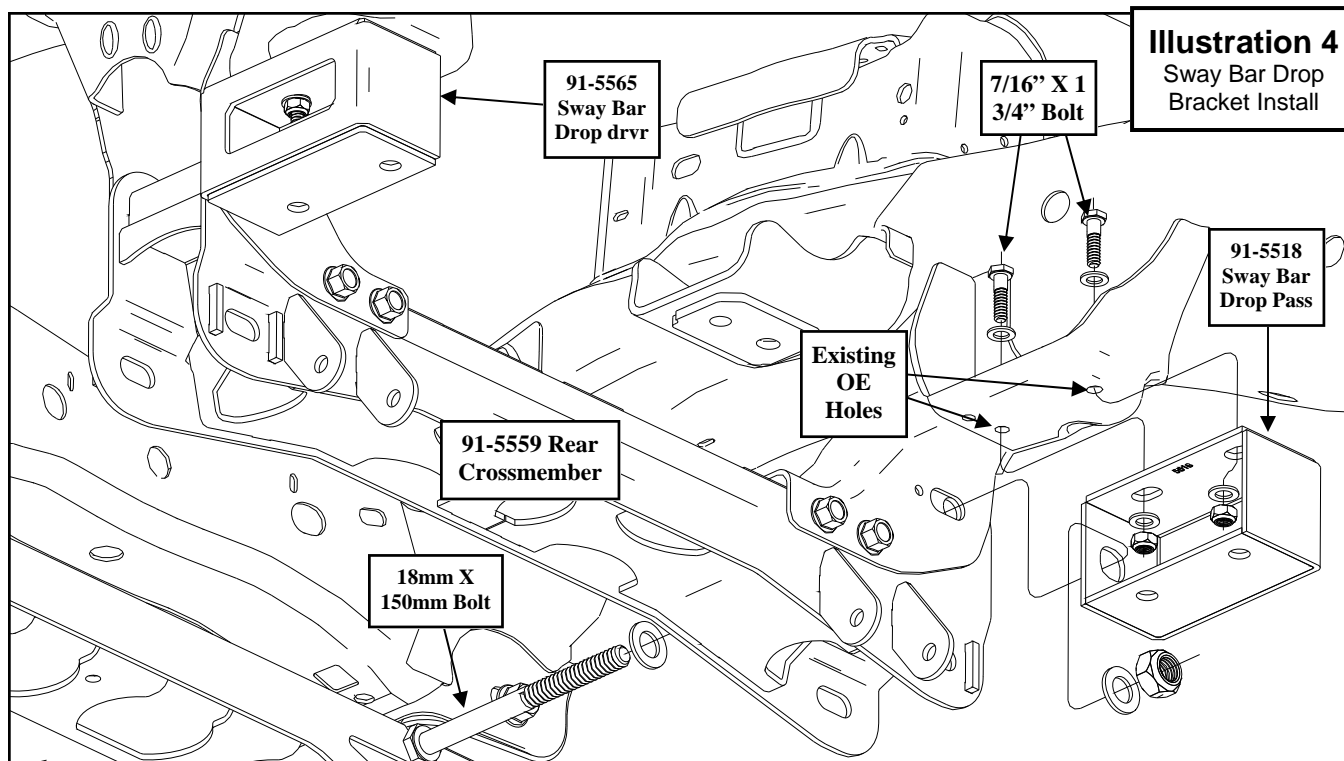

Illustration 2.

18. Raise the rear crossmember (91-5559) into place and install the (4) OE crossmember support brace bolts into the (4) crossmember brace holes on the driver and passenger side of the rear crossmember.

Leave the bolts loose. See **Illustration 3.**

19. Install the sway bar drop brackets (91-5565 driver and 91-5518 passenger) using the supplied 18mm X 150mm crossmember bolts. Install the bolts with the heads to



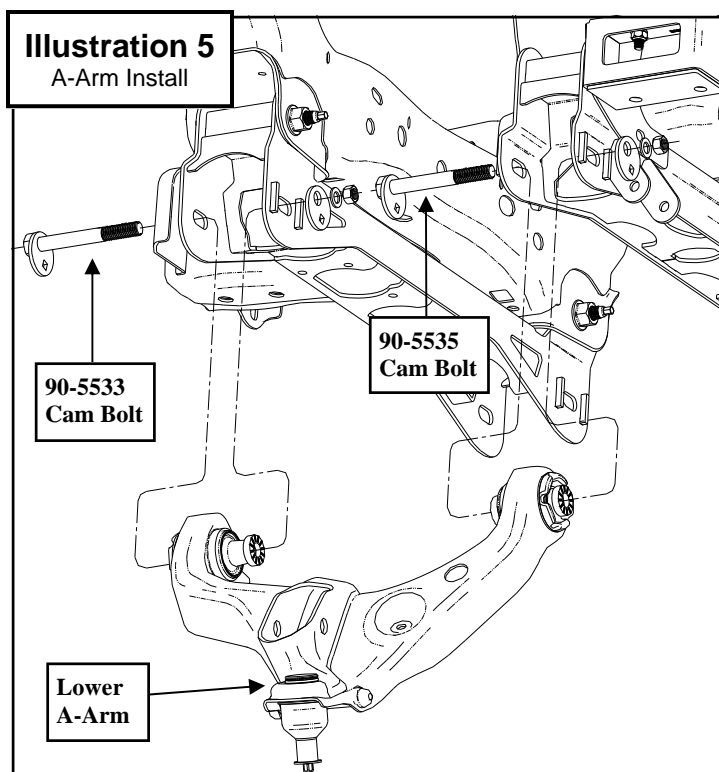

the front. Leave the bolts loose. See **Illustration 4**.

20. Secure the sway bar drop brackets (**91-5565 drvr** and **91-5518 pass**) to the **OE** sway bar mounting holes in the frame using the supplied **7/16" X 1 3/4"** bolts and hardware. Leave the bolts loose. See

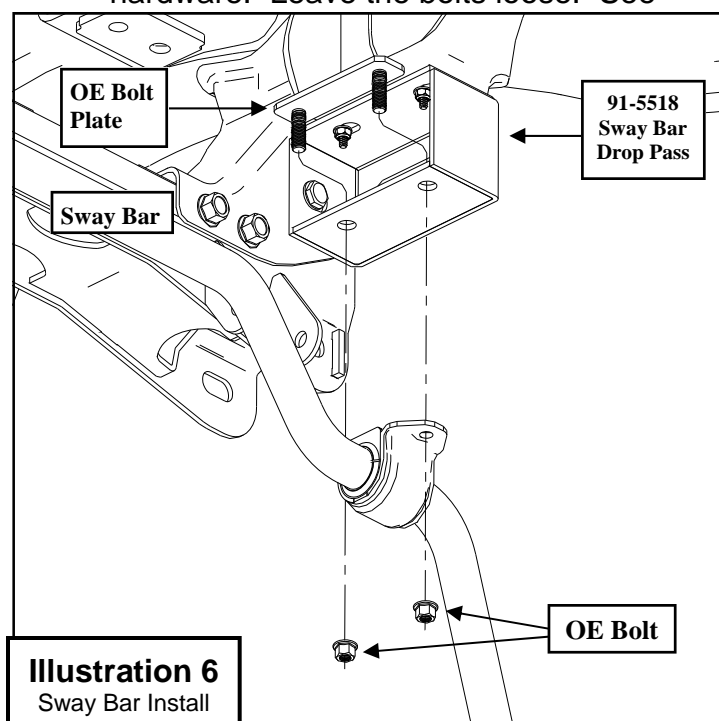

Illustration 6
 Sway Bar Install

Illustration 4.

21. Install the lower a-arms into the new cross members with the supplied cam bolts (**90-5533 front** and **90-5535 rear**), cam eccentric (**90-5532**), **18mm** washers and nuts. The cams should fit between the cam guides on the cross members. Center the cams in the guides. You will torque the bolts at the end of the install when the vehicle is on the ground. See **Illustration 5**.
22. Torque all crossmember and sway bar hardware according to the torque chart on page **18** or to manufacturers specifications.
23. Transfer all the parts (*except the **OE dust shields***) from the factory knuckles to the supplied Pro Comp knuckles (**90-4253 drvr** and **90-4254 pass**).

NOTE: Tighten all the factory hardware carefully. Be sure to follow the factory assembly procedures and torque specifications.

24. Install the sway bar frame mounts to the sway bar drop brackets using the previously removed **OE** bolt plate and hardware. See **Illustration 6**.
25. Secure the sway bar end links to the sway bar using the previously removed **OE** hardware.
26. Torque the sway bar mount hardware to **60** ft./lbs.
27. **STRUT SPACERS** (ILLUSTRATION 7): Scribe an index mark on the top of the **OE** coil spring to the upper strut mount.
28. Mark the orientation of the lower mount cross pin.

CAUTION: The coil is under extreme pressure and severe bodily injury may occur if the coil spring is disassembled without using a coil spring compressor.

29. Compress the coil spring on the strut as-

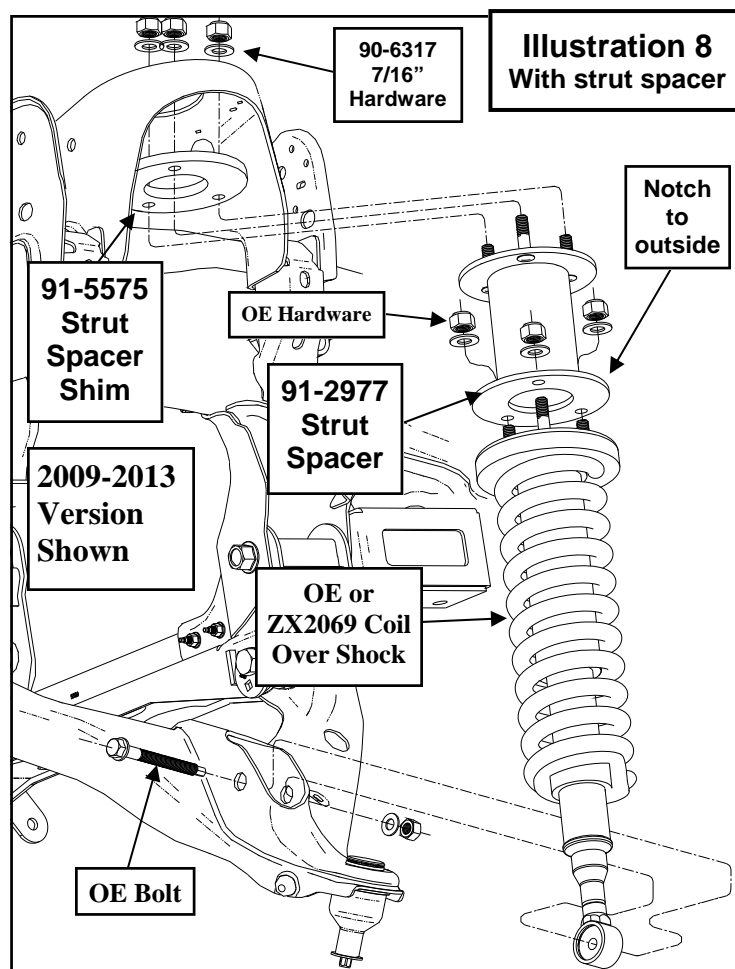
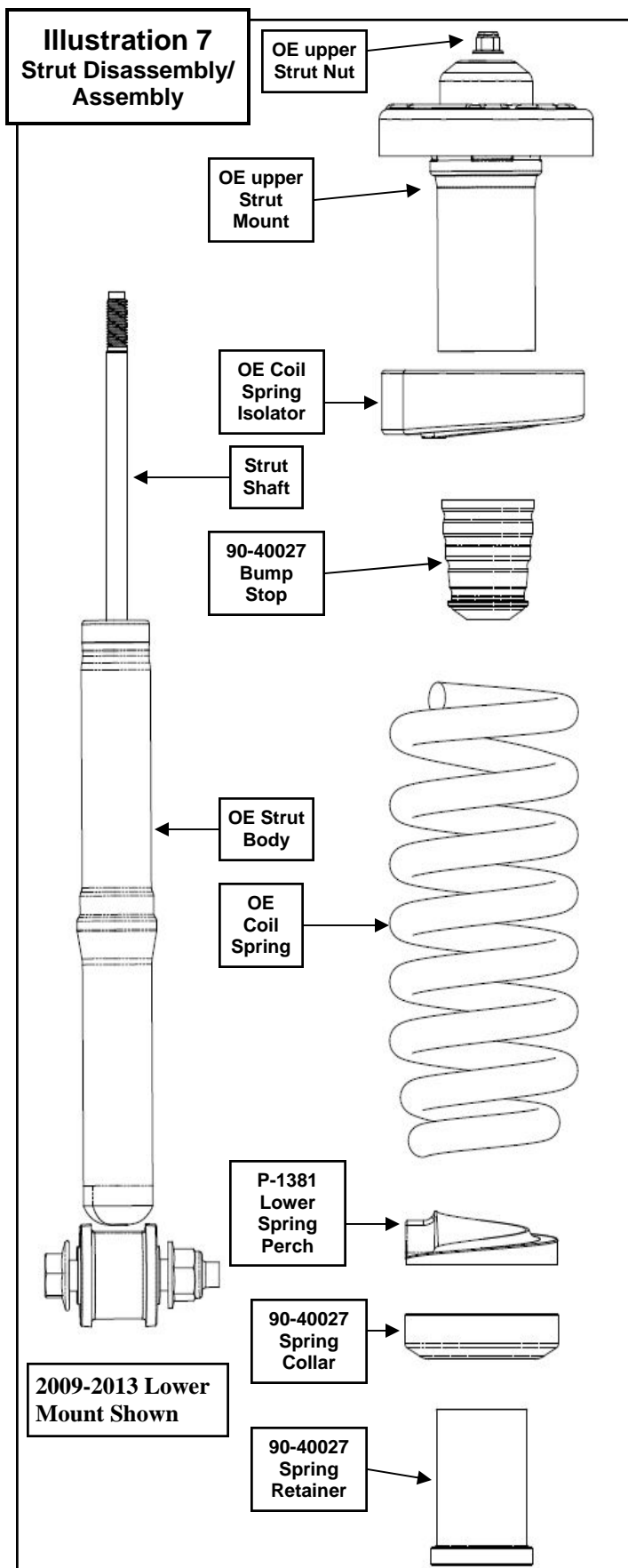

sembly with a suitable coil spring compressor so that the coil spring has about $3/8$ " play in the strut and remove the upper strut isolator retaining nut.

NOTE: Do not use an impact gun to remove the retaining nut. It will damage the strut shaft.

30. Remove the **OE** coil spring isolator from the upper strut mount. Save the isolator for reuse.

NOTE: Inspect the front shock assembly for any damage or fluid leakage. Replace if necessary.

31. Remove the **OE** bump stop from the upper strut mount.

NOTE: Be sure to note the orientation of the bumpstop in the upper strut mount

32. Carefully remove the coil spring from the strut.
33. Remove the **OE** lower spring perch from the strut by carefully tapping it with a hammer
34. Remove the **OE** coil spring retainer.
NOTE: The seal protector may need to be removed to allow the coil spring retainer to be slid off.
35. Install the new spring retainer (**31-40024**) onto the **OE** strut body
36. Install the spring collar (**61-40025**) over the spring retainer (**31-40024**) with the flat side facing up.
37. Install the lower spring perch (**P-1321**) and seat onto the spring collar (**61-40025**).
38. Reinstall the **OE** seal protector onto the strut body.
39. Install the new bump stop (**90-40027**) onto the strut shaft in the same orientation as the **OE** bump stop.
40. Reinstall the compressed coil spring onto the strut assembly using the reference marks as a guide.
41. Install the **OE** spring isolator and the upper strut mount onto the strut assembly.
42. Re-attach the upper strut mount using the **OE** hardware. Torque the upper strut mounting plate retaining nut to **20** ft./lbs.
NOTE: Failure to properly tighten the upper strut mounting nut will result in suspension noise.
43. Decompress the coil spring on the strut assembly. Make sure that the spring is seated correctly into the strut assembly and aligned with the previously scribed index mark on the upper strut mounting plate.

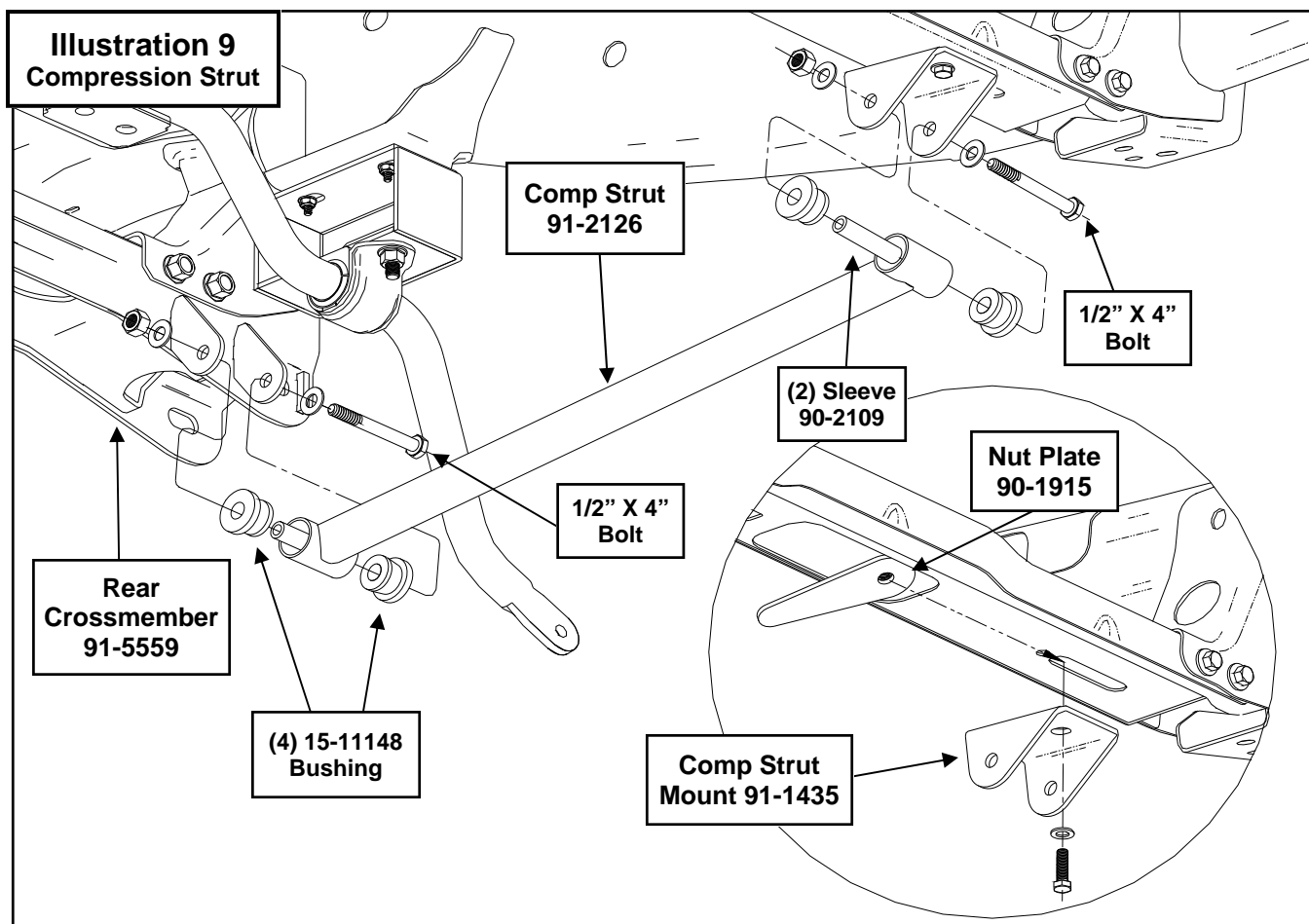

44. Attach the spacer (**91-2977**) to the top of the shock using the previously removed **OE** hardware. See **Illustration 12b**.
45. Install the strut assembly into the strut mounting locations. Secure using the **7/16"** supplied hardware on the top from hardware pack (**90-6317**). Torque to **45-50** ft./lbs. See **Illustration 12b**.
46. **2009-2013 models:** Install the **OE** bolt through the lower shock mount and a-arm. See **Illustration 12a**. Torque to factory specifications. **2014 models:** Secure the lower shock mount bar pin to the a-arm using the previously removed **OE** hardware.
47. Repeat steps 27 through 46 on the remaining side of the vehicle.
48. Remove stock brake line bracket from frame. Carefully remount the brackets with the supplied brake line drops (**90-3202 drv** and **pass**) in between bracket and frame. Use factory hardware to fasten the shorter end of the bracket to the frame. Position the drops, best for your application. Use the supplied hardware from pack (**90-6299**) to fasten **OE** bracket to the new brake line drop.

WARNING!: Make sure the brake lines that you just modified are not resting against any moving parts.
49. Support the lower A-arms. Position the new front knuckles. Attach the knuckle to the lower ball joint. Torque to **111** ft./lbs.
50. Attach the knuckle to the upper ball joint. Torque to **85** ft./lbs.
51. Connect the anti-lock wiring harness and sensor to the hub.
52. Attach the **OE** dust shields to the knuckle using the previously removed **OE** bolts.
53. Install the supplied brake line bracket (**91-7210**) to the upper hole in the knuckle, with the hole facing downward, using the previously removed **OE** bolt.
54. Secure the **OE** brake line bracket on the front brake line to the new bracket (**91-7210**) using the **5/16" X 1"** bolt and hardware.
55. Install the front rotors on to the front hub.
56. Install the front calipers on to the front rotors by reinstalling the retaining bolts. Torque to factory specifications.

NOTE: On some 2010-2014 models, the installation of the caliper bolt spacers (90-6736 2 per side) will be necessary to keep the end of the bolts from contacting the brake rotor.

NOTE: For 2010-2014 models ONLY, the brake caliper mounting bracket holes will need to be drilled out to 5/8". Also the casting nubs on the caliper mounting brackets (the bottom flat surface near the mounting holes) may need to be sanded smooth for brake caliper installation.
57. Install the tie rod end to the knuckle. Torque to **111** ft./lbs.
58. Repeat the installation on the other side of the vehicle.
59. Install the bushings (**15-11148**) and sleeves (**90-2109**) from hardware pack (**90-6263**) into the compression struts (**91-2126**). See **Illustration 9**.
60. Install the compression struts (**91-2126**) into the mounting tabs on the rear cross member using supplied **1/2" X 4"** hardware. See **Illustration 9**.
61. Place the supplied nut plates (**90-1915**) inside the transmission cross member and attach the mounts (**91-1435**) using the supplied **1/2" X 1 1/4"** bolt and washers. See **Illustration 9**.
62. Rotate the compression struts (**91-2126**) up and secure them to the mounts using the supplied **1/2" X 4"** hardware. See **Illustration 9**.
63. Torque all compression strut hardware according to the torque chart on page **18**.

64. Reinstall the wheels and tires and lower the vehicle to the ground. Torque the factory wheels to **150** ft./lbs. If you are using aftermarket wheels follow the manufacturers recommended specifications.
65. Torque the **18mm** cam bolts to **180-200** ft./lbs.
66. Recheck all hardware for proper installation and torque at this time.
67. On both sides of the vehicle, check the routing of the brake lines and the ABS wire harnesses. There must be no pinching, rubbing, or stretching of either component. Use zip ties to secure these items. At full droop, cycle the steering from lock to lock while observing the reaction of these components. Reposition them if needed.

NOTE: SEE PAGE 16 FOR STEERING STOP ADJUSTMENT INSTRUCTIONS

IMPORTANT! BE SURE TO BRING THE VEHICLE IMMEDIATELY TO A REPUTABLE ALIGNMENT SHOP TO BE ALIGNED!

IMPORTANT! SOME 2WD LONG BED VERSIONS MAY NOT NEED TO HAVE THE STRUT SPACERS (91-5575) INSTALLED. IF THE FRONT OF YOUR VEHICLE MEASURES OVER 28 5/8" TALL FROM THE HUB CENTER LINE TO THE EDGE OF THE WHEEL WELL, THEN YOU NEED TO REMOVE THE 3/8" THICK STRUT SPACER (91-5575) TO ACHIEVE THE DESIGNED RIDE HEIGHT OF 28 1/8" (+/- 3/8")

IMPORTANT!: AFTER INSTALLATION OF KIT AND BEFORE THE VEHICLE IS FIRST STARTED, BE SURE TO CENTER THE FRONT WHEELS AND THE STEERING WHEEL. IF THE FRONT WHEELS AND THE STEERING WHEEL ARE NOT CENTERED BEFORE STARTING THE VEHICLE, IT MAY TRIGGER A DIAGNOSTIC TROUBLE CODE THAT WILL HAVE TO BE RESET BY THE MANUFACTURERS SERVICE FACILITY.

Rear Installation:

1. Block the front tires and raise the rear of the vehicle. Support the frame with jack stands forward of the rear springs.
2. Remove the rear wheels.
3. Remove the shocks on both sides of the vehicle. It may be necessary that you slightly raise the axle to unload the shocks for removal.
4. On drivers side, unbolt the existing brake line bracket from the frame.
5. Install the supplied brake line extension bracket (**90-5502**) to the frame using the previously removed **OE** hardware. Then bolt the factory bracket to the new bracket using the supplied **5/16" X 1"** hardware from hardware pack (**90-6314**).
6. Reroute rear ABS as necessary use the supplies zip ties to secure lines.
7. Unhook the emergency brake cable and remove from **OE** metal wire clip by pinching the tangs on the line.
8. Bolt the supplied emergency brake bracket (**91-7826**) to the **OE** emergency brake bracket using the supplied **1/2" X 1 1/2"** Bolt. See **Illustration 10**.
9. Use the inside hole in the emergency brake bracket as a guide for drilling through the frame. See **Illustration 10**.
10. Center punch and drill the holes using a **3/8"** drill bit. See **Illustration 10**.
11. Secure the emergency brake bracket (**91-7826**) to the frame using the **3/8" X 1 1/2"** bolt. See **Illustration 10**.
12. Slip the cable through new bracket (**91-7826**) and re-connect the emergency brake cable.

NOTE: 2012-2014 models will re-use the previously removed OE metal wire clip and OE bolt to secure the emergency brake cables to the new bracket.

13. Support the rear axle with a floor jack and remove the **U-bolts** on the driver side. Loosen the **U-bolts** on the passenger side.
14. Remove the factory lift block from the spring assembly. This will not be re-installed.
15. Install the lift block (**95-204F**) onto the axle pad, making sure the pins are fitted into the holes on the spring perch. Use your floor jack to raise the axle to the spring making sure the tabs on the spring block fit into the holes on the lift block. See **Illustration 11**.

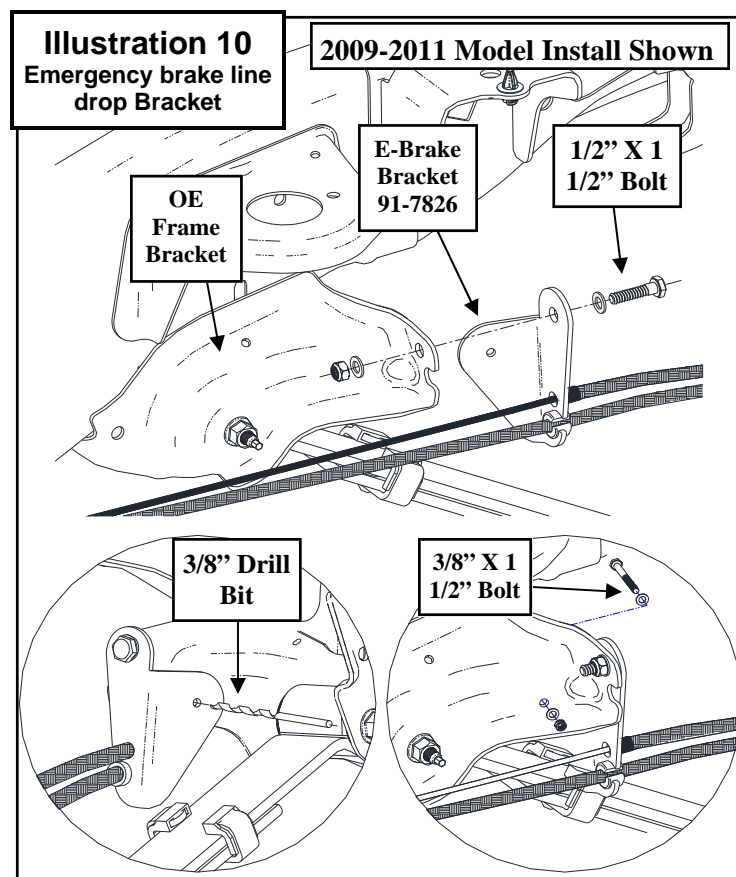

16. Secure the assembly with the U-bolts (**13-90385**) supplied in hardware pack and new high-nuts and washers from hardware pack (**20-65302**). Do not tighten the **U-bolts** at this time. See **Illustration 11**.

NOTE: Make sure the block sits flush on the axle perch.

17. Repeat the installation on the other side of the vehicle.

18. When the installation of the remaining side is complete, torque the **U-bolts** to **105** ft./lbs.

19. Remove the factory bump stops from the vehicle. Save the bolts for reinstallation.

20. Assemble the bump stop drop halves (**PN 91-5774**) and install the **OE** bump stops to the bump stop drop assemblies using the supplied **3/8" X 1 1/2"** bolts. See **Illustration 12**.

NOTE: Be sure that the pins on the OE bump stops fit into the holes in the bump stop drop assemblies.

21. Install the bump stop drop assemblies (**PN 91-5774**) to the frame using the

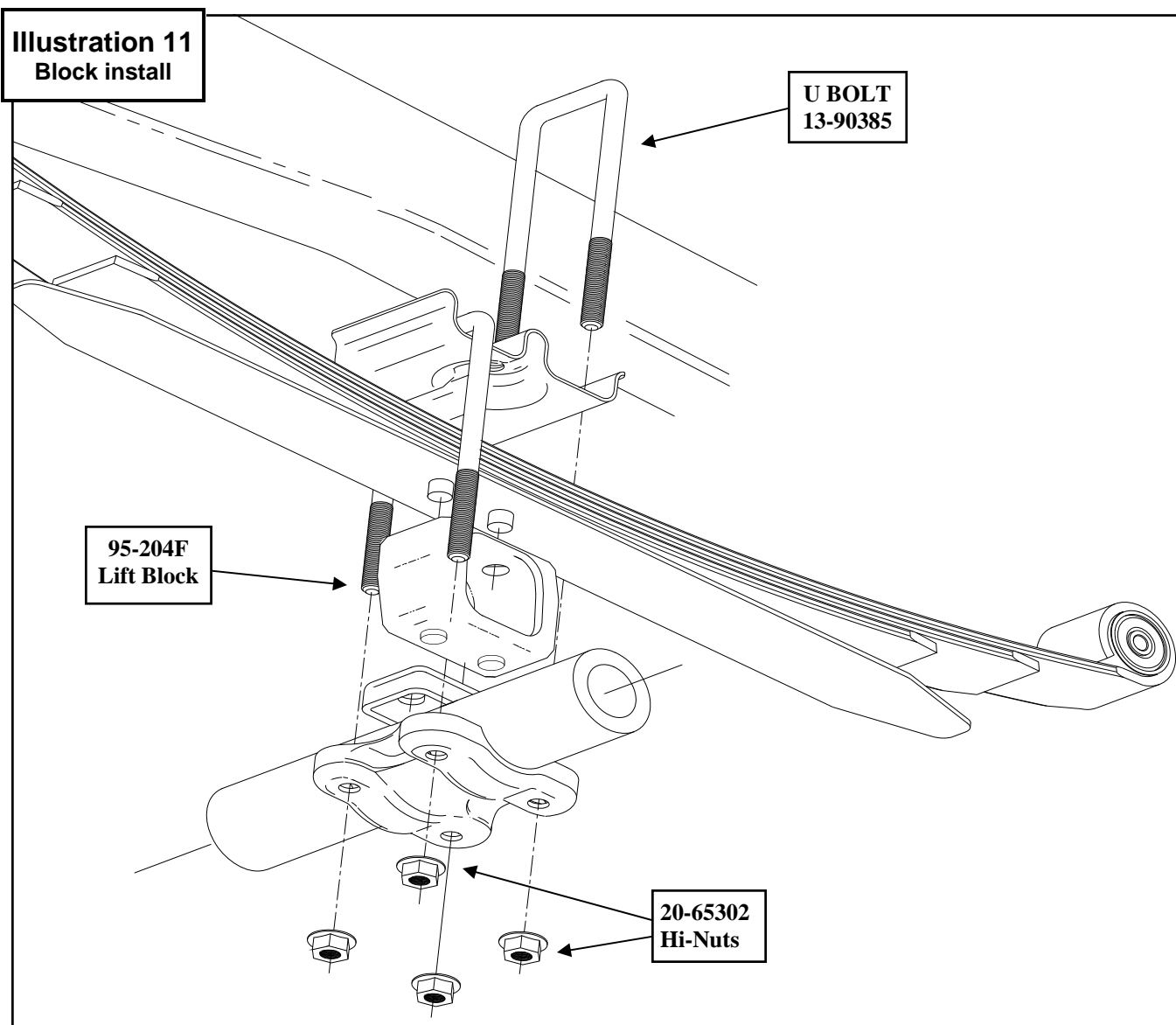

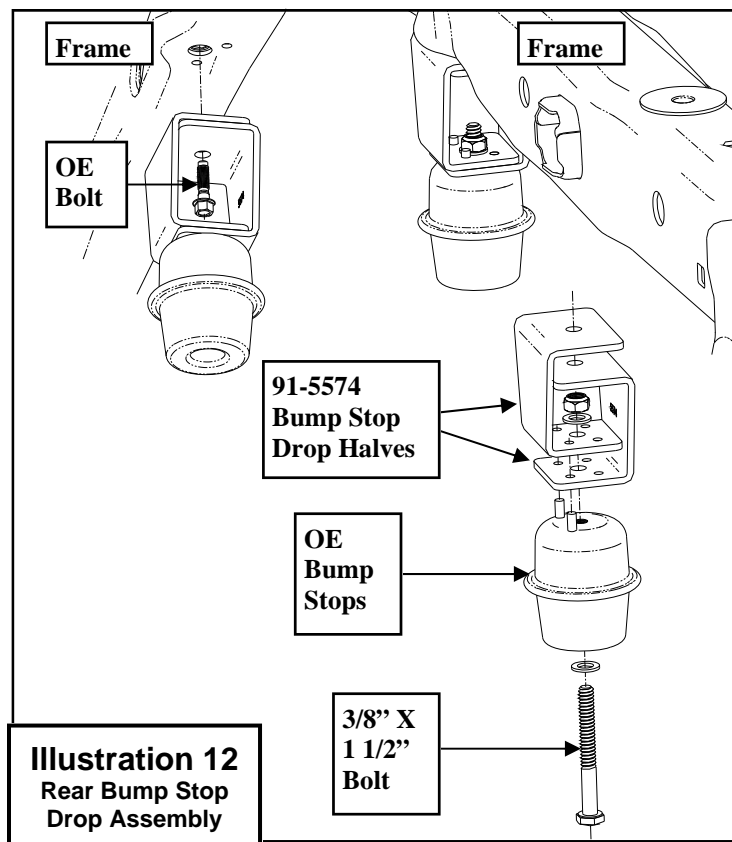

NOTE: If driveshaft vibration occurs, install the carrier bearing shim kit (90-6569) using the 3/8" X 1 1/2" bolts and hardware from pack (90-6013). Not all vehicles will use the same combination of shims. Only by driving the vehicle and adding or removing shims can the vibration be eliminated.

NOTES:

- ⇒ On completion of the installation, have the suspension and headlights re-aligned.
- ⇒ After 100 miles recheck for proper torque on all newly installed hardware.
- ⇒ Recheck all hardware for tightness after off road use.

previously removed **OE** bolts. See **Illustration 12**.

22. Insert the supplied sleeves (**60859**) in both end of the shocks.

23. Install your new Pro Comp shocks (**MX6166, 932008 or ZX2071 w/ shaft end up**) and torque this hardware to **66** ft./lbs.

24. Reinstall the wheels and tires and lower the vehicle to the ground. Torque the factory wheels to **150** ft./lbs. If you are using aftermarket wheels follow the manufacturers recommended specifications.

NOTE: If you wish to raise the ride height of the rear of the vehicle, Install the rear leaf spring shims from hardware pack (90-6703) using the enclosed instructions.

26. Recheck all hardware for proper installation and torque at this time.



PRO COMP SUSPENSION

Suspension Systems that Work!

Steering Stop Shim Adjustment Instructions:

1. After having the vehicle properly aligned by a qualified alignment shop, ensure that your work space is of adequate size and the work surface is level. Place the vehicle in park and set parking brake. Place blocks both in front of and behind the rear wheels.
2. With the vehicle on the ground make sure the steering wheel and the tires are straight.
3. Turn the steering wheel to full lock left and remove the appropriate shims from the passenger side front stop and the driver side rear stop until the steering wheel at full lock is in the same position as **Illustration A**.
4. Turn the steering wheel to full lock right and remove the appropriate shims from the driver side front stop and the passenger side rear stop until the steering wheel at full lock is in the same position as **Illustration B**.
5. Be sure to use thread locking compound on the 5/16" X 1" shim retaining bolts. See **Illustration C**.

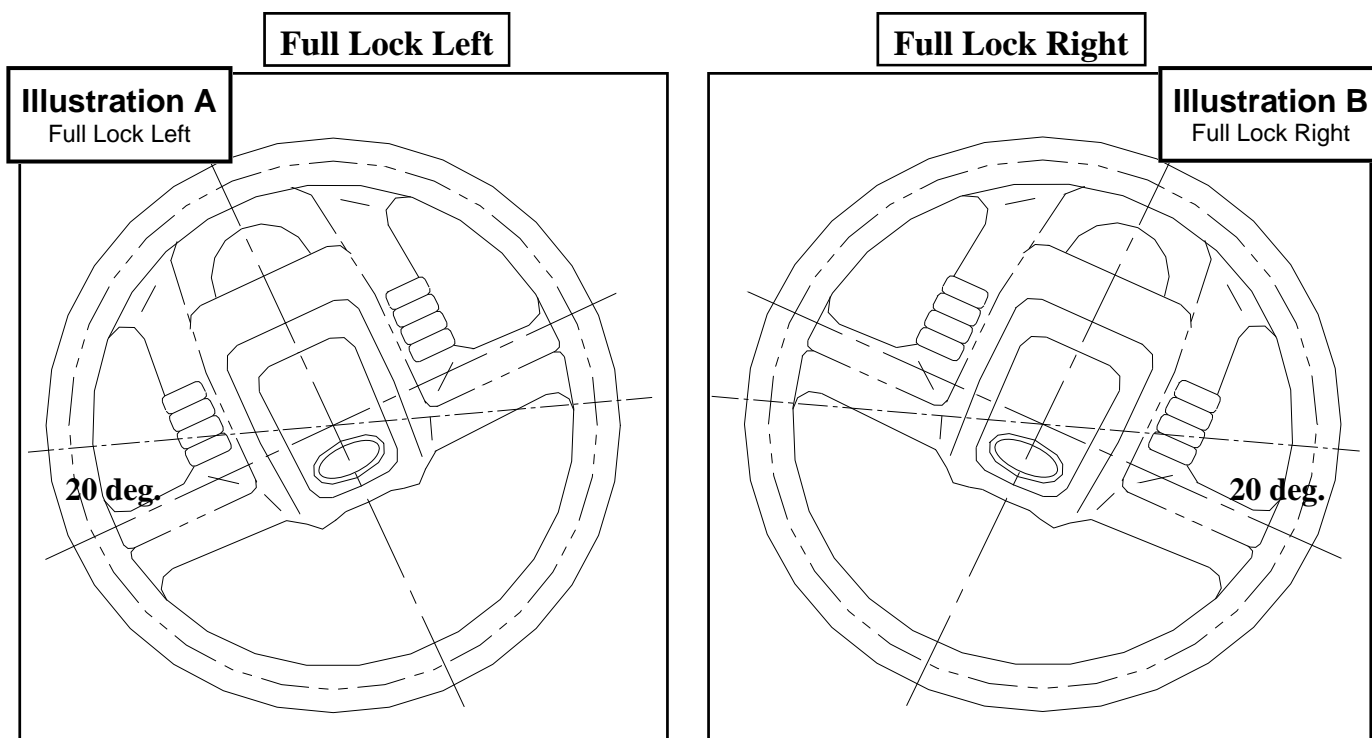

IMPORTANT!: Any more steering angle than shown in the illustrations may result in CV failure.

Illustration C
Shim Installation

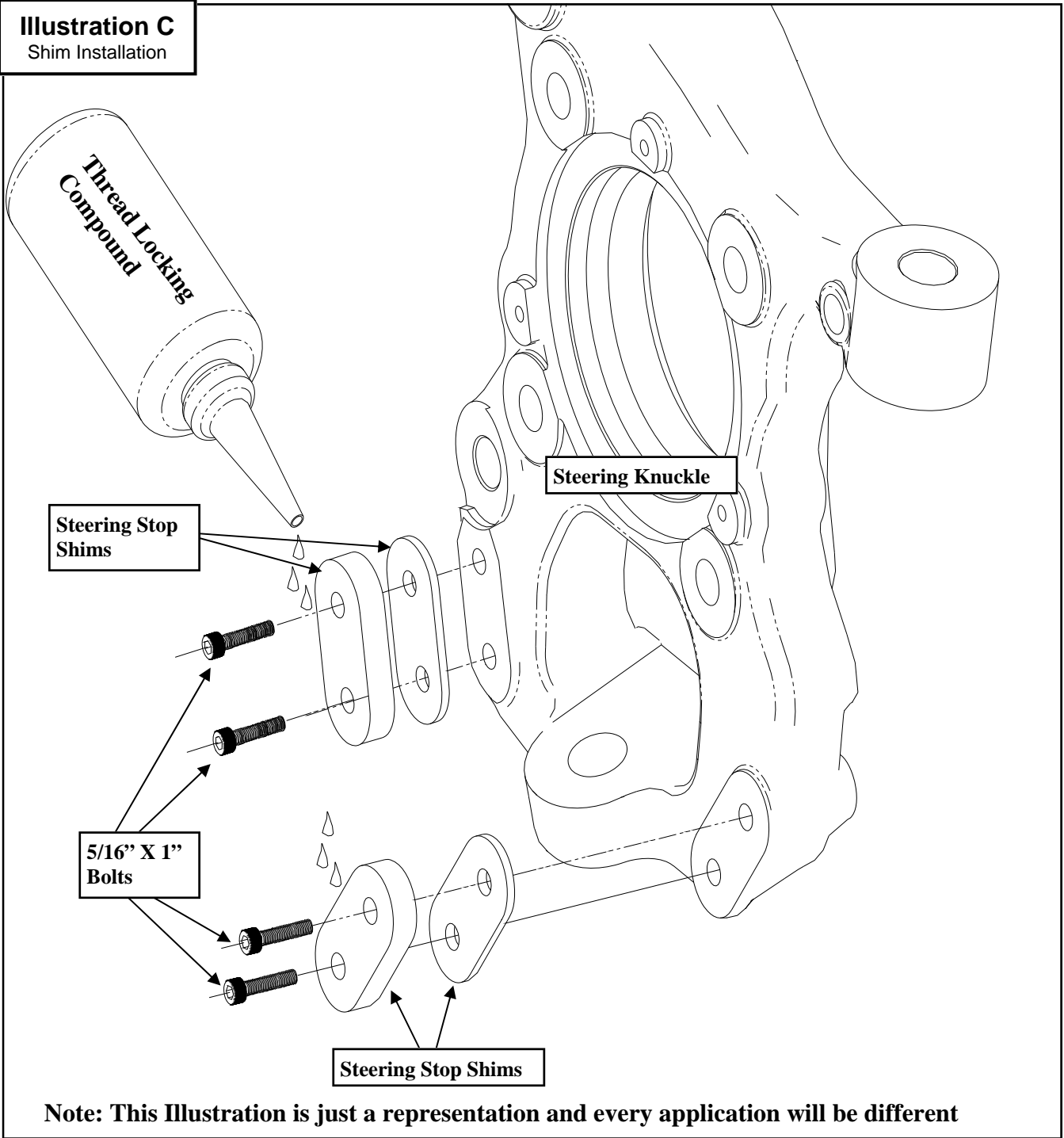

Note: This Illustration is just a representation and every application will be different

Use this only as a guide for hardware without a called out torque specification in the instruction manual.

Bolt Torque and ID						
Decimal System			Metric System			
All Torques in Ft. Lbs. Maximums						
Bolt Size	Grade 5	Grade 8	Bolt Size	Class 9.8	Class 10.9	Class 12.9
5/16	15	20	M6	5	9	12
3/8	30	45	M8	18	23	27
7/16	45	60	M10	32	45	50
1/2	65	90	M12	55	75	90
9/16	95	130	M14	85	120	145
5/8	135	175	M16	130	165	210
3/4	185	280	M18	170	240	290

1/2-13x1.75 HHCS
D T L X

Grade 5 **Grade 8**
 (No. of Marks + 2)

G = Grade (Bolt Strength)
 D = Nominal Diameter (Inches)
 T = Thread Count (Threads per Inch)
 L = Length (Inches)
 X = Description (Hex Head Cap Screw)

M12-1.25x50 HHCS
D T L X

P = Property Class (Bolt Strength)
 D = Nominal Diameter (Millimeters)
 T = Thread Pitch (Thread Width, mm)
 L = Length (Millimeters)
 X = Description (Hex Head Cap Screw)

Revision Page:

12.20.2011: Removed rear emergency brake cable **90-5503** from BOM box-3 and replaced it with **91-7826**. Updated text to include 2012 model note. Changed Illustration #10.

12.17.2012: Installed 52213BPS and 52213BPX BOM and PN information.

2.11.2013: Changed the front knuckle brake line bracket in BOM box-2 to 91-7210. Added box-4BP to the BOM. Updated the options box.

9.6.14: Changed knuckle PN's from 90-4253 and 90-4254 to 90-4624 and 90-4625.



The PRO COMP PROMISE WARRANTY

At Pro Comp, we know you have many choices when selecting products to personalize your vehicle. You should demand nothing but the highest quality available and have total confidence that the products you selected are the best in the industry. It is for these reasons that Pro Comp Suspension products are backed by the best warranty in the industry...the Pro Comp Promise!

Pro Comp promises that its products will last a lifetime or we will replace it free of charge. It's that simple! Because of our commitment to quality and manufacturing excellence, we are able to stand behind our products. FOREVER.

It is Pro Comp's Promise that if one of our suspension products breaks not due to misuse, neglect or vandalism, we will replace it. Whether you are the original purchaser or not, you can be assured that we will make it right. The Pro Comp Promise covers all suspension products including shocks and steering stabilizers. Buy Pro Comp Suspension today and enjoy it for the rest of your life!

That's our Pro Comp Promise!

Notice to Owner, Operator, Dealer and Installer:

Vehicles that have been enhanced for off-road performance often have unique handling characteristics due to the higher center of gravity and larger tires. This vehicle may handle, react and stop differently than many passenger cars or unmodified vehicles, both on and off-road. You must drive your vehicle safely! Extreme care should always be taken to prevent vehicle rollover or loss of control, which can result in serious injury or even death. Always avoid sudden sharp turns or abrupt maneuvers and allow more time and distance for braking! Pro Comp reminds you to fasten your seat belts at all times and reduce speed! We will gladly answer any questions concerning the design, function, maintenance and correct use of our products.

Please make sure that the Dealer / Installer explains and delivers all warning notices, warranty forms and instruction sheets included with Pro Comp product.

Warranty and Return Policy:

Pro Comp warranties its full line of products to be free from defects in workmanship and materials for the life of the product. Pro Comp's obligation under this warranty is limited to repair or replacement, at Pro Comp's option, of the defective product. Any and all costs of removal, installation, freight or incidental or consequential damages are expressly excluded from this warranty. Pro Comp is not responsible for damages and / or warranty of other vehicle parts related or non-related to the installation of Pro Comp product. A consumer who makes the decision to modify his vehicle with aftermarket components of any kind will assume all risk and responsibility for potential damages incurred as a result of their chosen modifications. Warranty coverage does not include consumer opinions regarding ride comfort, fitment and design. Warranty claims can be made directly with Pro Comp or at any factory authorized Pro Comp dealer.

IMPORTANT! To validate the warranty on this purchase please be sure to mail in the warranty card.

Claims not covered under warranty

* Parts subject to normal wear; this includes bushings, bump stops, ball joints, tie rod ends and heim joints.

* Finish after 90 days.

* Damage caused as a result of not following recommendations or requirements called out in the installation manuals.

Pro Comp MX Series coil-over shocks are considered a serviceable shock with a one-year warranty against leakage only. Rebuild service and replacement parts will be available and sold separately by Pro Comp. Contact Pro Comp for specific service charges. Pro Comp accepts no responsibility for any altered product, improper installation, lack of or improper maintenance or improper use of our products.

E-Mail: info@procompusa.com
Website: www.procompusa.com
Fax: (310) 747-3912
Ph: 1-800-776-0767

<u>PLACE</u> <u>WARRANTY REGISTRATION</u> <u>NUMBER</u> <u>HERE:</u> _____
