

# AT-9523PT

MUFFLER ASSEMBLY, 5" SLIP-ON  
2017-2020 POLARIS SPORTSMAN 1000 XP  
2017-2019 SPORTSMAN 850 SP

# MBRP

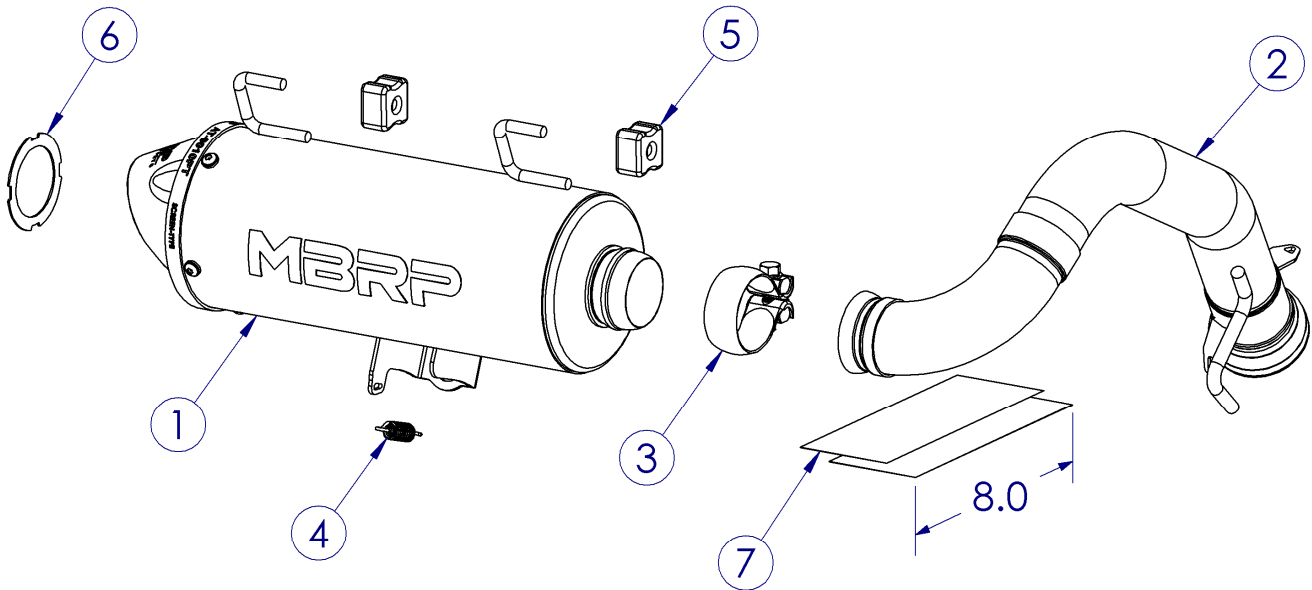

ITEM NO.	DESCRIPTION	QTY
1	MUFFLER ASSEMBLY	1
2	INLET PIPE	1
3	INLET CLAMP	1
4	EXTENSION SPRING	1
5	RUBBER MOUNT	2
6	SPACER INSERT	1
7	FOIL TAPE	2

## PLEASE READ BEFORE STARTING INSTALLATION

While MBRP Ltd. has made every effort to ensure that all components of this system are of superior quality and properly packaged, it is the installer's responsibility to ensure the following before removal of the factory exhaust:

- that ALL components shown above are present.
- that ALL mating components fit together.
- that there are no damaged components.
- that the system you have purchased is appropriate for your vehicle year, model and configuration.
- that the system will not interfere with any modifications previously installed or planned.
- that you have read and understand these instructions.

If you have any questions or are uncertain about any aspect of the installation of this system to your vehicle please contact your dealer before commencing installation.

# MBRP

## Removal of Stock Exhaust:

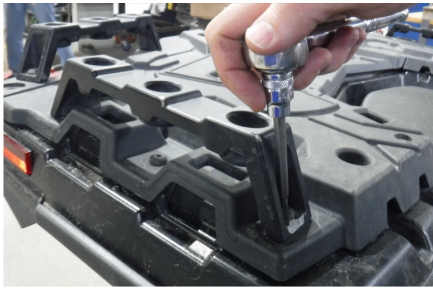

Figure 1



Figure 2

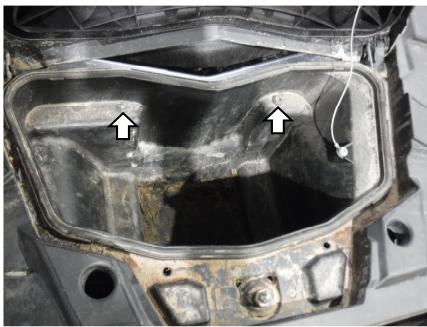

Figure 3



Figure 4

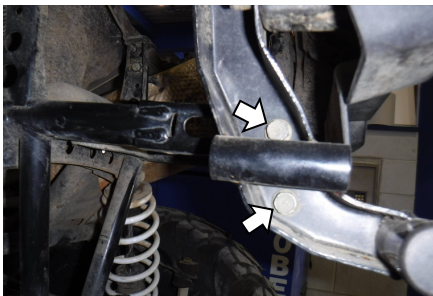

Figure 5

1. In order to remove the stock exhaust, the rear rack and support frame need to be removed. If your vehicle has an added rear bumper, it may be helpful to remove this as well.

2. Beginning with the extender handles/tie-downs, loosen and remove the hardware securing the extenders to the rack and support frame. Keep the hardware and note where it was removed from, as it will need to be reinstalled. Set the extenders aside.

**Refer to Figure 1**

3. Remove the four (4) screws securing the rack on the top surface (**Refer to Figure 2**) and the two (2) inside the storage box (**Refer to Figure 3**), then remove the molded rack assembly to expose the support frame.

4. Disconnect the wiring to the taillights and free the wiring harness from the rear support frame (this will require removing the cable-ties from the support frame as well).

**Refer to Figure 4**

5. Remove the four (4) bolts (2 per side) securing the support frame to the frame of the vehicle, then remove the support frame. **Refer to Figures 5 and 6**

6. Now that the rear structure is out of the way, the stock muffler can be removed. Remove the two springs at the muffler inlet (they will be reused), then work the muffler straight back to free the hangers from their mounts. If the inlet gasket came off of the front pipe with the muffler, place it back onto the pipe to use with the new exhaust.



Figure 6

## Installation of MBRP Exhaust:

1. Place the **Inlet Pipe** into position with the hanger in the rubber mount and the inlet cup over the gasket. **Refer to Figure 7**

2. Install the two stock springs onto the **Inlet Pipe** and then place the **Inlet Clamp** over the other end.

# MBRP



Figure 7



Figure 8



Figure 9



Figure 10



Figure 11

3. Slide the two **Rubber Mounts** into the channels of the upper frame rails with the notches oriented on the top and bottom sides. Position the mounts so that the holes line up near the centre of the open slots. Refer to **Figure 8**

4. Put the **Muffler Assembly** into position by placing the muffler hangers into the **Rubber Mounts**. Refer to **Figure 9**

5. Place the bottom bracket of the **Muffler Assembly** over the center locator and secure it into position by installing the provided **Extension Spring**. Refer to **Figure 10**

6. Adjust the **Inlet Pipe** and **Muffler Assembly** as necessary to line up the muffler inlet with the pipe outlet. Note that the **Rubber Mounts** can be adjusted as required. Once aligned, move the **Inlet Clamp** into position and tighten it fully to secure the connection.

7. With the new exhaust installed, replace the rear support frame and reconnect the wiring. Ensure that the cabling is routed to maintain adequate clearance to the new exhaust.

8. Replace the rack assembly - it is recommended to first apply the supplied **Foil Tape** to the underside of the rear storage compartment to limit heat transfer. See **Figure 11**

9. Finally, ensure all parts and hardware are in their proper place and fastened securely.

It is recommended that the muffler screws be retightened after the first ride and checked periodically thereafter, tightening if necessary.



**Congratulations!** You are ready to begin experiencing the improved performance and driving excitement of your MBRP ATV Exhaust upgrade. We know you will enjoy your purchase.



**Figure 1**



**Figure 2**



**Figure 3**



**Figure 4**

## Spark Arrestor Maintenance

In order to maintain optimal performance, the spark arrestor screen should be cleaned after every 30-35 hours of use.

### Clean-out Instructions:

Make sure the vehicle is cool before completing the clean-out procedure.

1. Using a 4mm hex key, remove the 4 screws securing the outlet cap or tip. **(Figure 1)**
2. Remove the outlet cap to expose the spark arrestor screen insert. **(Figure 2)**
3. Remove the screen insert. **(Figure 3)**
4. Using a wire brush, thoroughly brush the screen to remove residue. **(Figure 4)**
5. Replace the screen and cap.
6. Tighten the screws to 60 in-lbs (6.8 Nm).