



Installation Instructions

Dual Rear Exhaust

Ford Mustang GT Fast Back Coupe, 3.7L

Part #619015-B

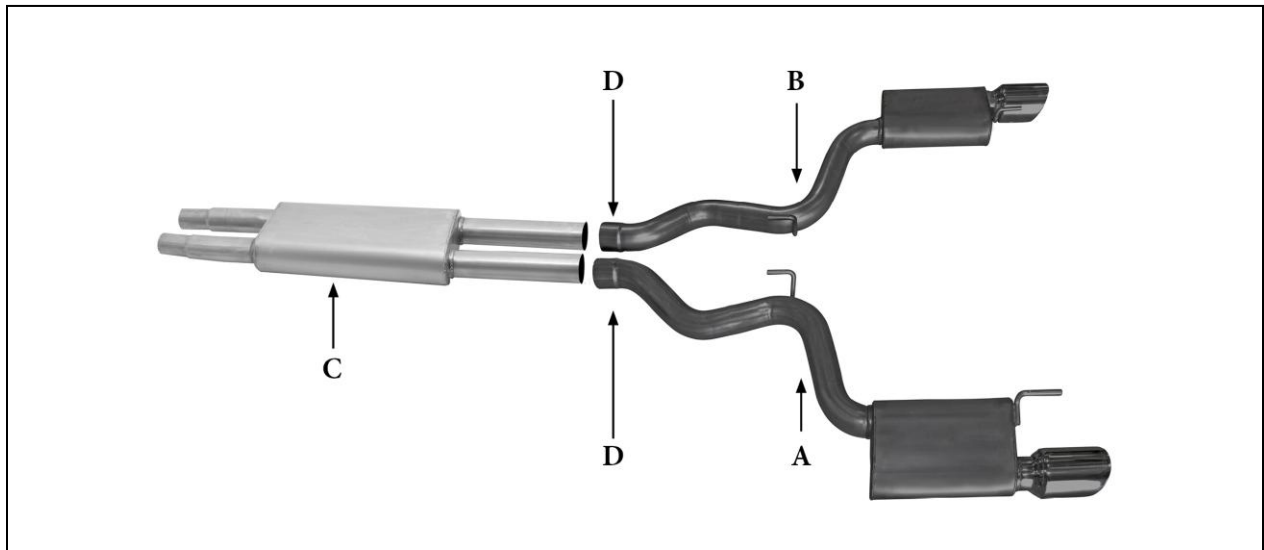

PART	QUANTITY	DESCRIPTION
A	1	Driver side tailpipe assembly with 4.5" Black intercooled tip
B	1	Passenger side tailpipe assembly with 4.5" Black intercooled tip
C	1	Muffler assembly
D	2	2.5" Clamp

Installation Instructions #619015-B

When installing this exhaust system make sure to use proper safety precautions. Use jack stands when working under the vehicle, set parking brake, block tires and use safety glasses and gloves. Allow exhaust to cool before attempting installation. Severe injury or burns could occur if safety measures are not taken.

SUGGESTED TOOLS: 1/2", 9/16", 15mm wrenches & sockets, WD-40, hacksaw, jack stands

1. Disconnect the negative battery cable before removal of OEM exhaust. This will allow the computer to reset and recognize the new exhaust. Lay out the exhaust on the floor so it looks like the drawing and compare parts with manual.



1. To remove your stock exhaust, unbolt it from the clamps located just after the manifolds then remove the whole exhaust system



4. Now do the same procedure for the driver side. Use clamp # D to secure to the muffler.



2. Install your Gibson muffler Assembly

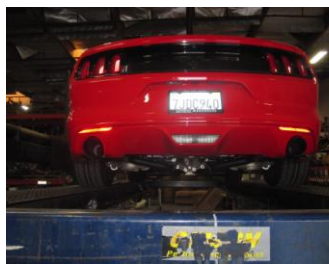

5. When you have everything in place, firmly tighten all bolts and clamps down securely. Use stainless steel cleaner and weekly to prevent tip from discoloration. Inspect all fasteners after 25-50 miles of operation and re-tighten as necessary.



3. Now install the passenger side tailpipe assembly #B by sliding the metal hangers into the rubber grommets. Use clamp #D to secure together.