



INSTALLATION INSTRUCTIONS

K2266DL 8" 4-LINK SYSTEM W/ DLSS SHOCKS (DIESEL)		
1	FT22025BK	8" COIL BOX (DIESEL)
1	FTS22221	4-LINK BOX 1
1	FTS22273	8" 4-LINK BOX 2
1	FTS22279	8" REAR BOX KIT
2	FTS810382	2.25 DIRT LOGIC SS N/R (FRONT)
2	FTS810052	2.25 DIRT LOGIC SS N/R (REAR)

K2298DL 8" 4-LINK SYSTEM W/ DLSS RESI SHOCKS (DIESEL)		
1	FT22025BK	8" COIL BOX (DIESEL)
1	FTS22221	4-LINK BOX 1
1	FTS22273	8" 4-LINK BOX 2
1	FTS22279	8" REAR BOX KIT
2	FTS800382	2.25 DIRT LOGIC SS W/RESI (FRONT)
2	FTS810052	2.25 DIRT LOGIC SS N/R (REAR)

K2302DL 8" 4-LINK SYSTEM W/ DLSS 4.0 RESI SHOCKS (DIESEL)		
1	FTS835237D	4.0 DIRT LOGIC W/ RESI (DRIVER)
1	FTS835237P	4.0 DIRT LOGIC W/ RESI (PASSENGER)
1	FTS22221	4-LINK BOX 1
1	FTS22273	8" 4-LINK BOX 2
1	FTS22279	8" REAR BOX KIT
2	FTS810052	2.25 DIRT LOGIC SS N/R (REAR)

2017-2019 FORD F250/350 SUPERDUTY 4WD 8" 4-LINK SYSTEM

FTS22273

This suspension kit requires a double cardan front driveshaft for installation.
Order Fabtech FTS92035 or contact your local driveline shop.

Fabtech Motorsports | 4331 Eucalyptus Ave. Chino, CA 91710

Tech Line: 909-597-7800 | Fax: 909-597-7185 | Web: www.fabtechmotorsports.com

- PARTS LIST -

FTS22025BK 8" FORD F250/350 FRONT COILS		
2	FT30124BK	6" FRONT COIL (DIESEL)

FTS22221 4-LINK BOX 1		
2	FT30129BK	LOWER LINK
2	FT30692	UPPER LINK
2	FT30650	4-LINK POCKET

FTS22273 8" 4-LINK BOX 2		
1	FT30122	PITMAN ARM
1	FT30672	STEERING STABILIZER BRACKET
1	FT30686	STEERING STABILIZER CLEVIS MOUNT
1	FT30767	TRAC BAR DROP BRACKET
1	FT30768	SWAY BAR RELOCATION BRACKET (DRIVER)
1	FT30769	SWAY BAR RELOCATION BRACKET (PASSENGER)
2	FT30770	SWAY BAR RELOCATION AXLE MOUNT
1	FT30773	HARDWARE SUBASSEMBLY
1	FT30782	TRACK BAR
2	FT30795	8" BUMP STOP EXT
1	FT30798	HARDWARE KIT
1	FT30414	TRAC BAR ROD END
1	FT30415	ADJUSTING SLEEVE

FT30773 HARDWARE SUBASSEMBLY		
8	FT147	MISALIGNMENT
1	FT22273i	INSTRUCTIONS
1	FT292	ALIGNMENT CAM KIT
1	FT30258	SECTOR SHAFT NUT
2	FT30262-3	TRACK BAR BUSHING
1	FT30262-4	TRACK BAR SLEEVE
2	FT30276	BRAKE LINE TAB
1	FT30604	SPACER
2	FT30698	SWAY BAR RELOCATION NUT TAB
2	FT30786	TRACK BAR WASHER
1	FT30765	SPACER
1	FT30797	TRACK BAR CLAMP
2	FT50290	BUMP STOP NUT TAB
1	FT94510	TRACK BAR UNIBALL PIN
1	FTAS12	STICKER FT BLUE 10X4 DIE CUT
1	FTAS16	DRIVER WARNING DECAL
1	FTLUBE	URETHANE GREASE
1	FTREGCARD	REGISTRATION CARD

FTS22279 8" REAR BOX KIT		
4	FT742U	U-BOLT RD 5/8-18 X 18.00 X 3.50
2	FT30284	LEAF SPRING SPACER
1	FTBK54D	BLOCK (DRIVER)
1	FTBK54P	BLOCK (PASSENGER)
1	FT58H	5/8" U-BOLT HARDWARE KIT
2	FT30781	ADD A LEAF
1	FT90080	CENTER PIN BOLT KIT

FT30798 - HARDWARE KIT		LOCATION
4	1/2-13 X 1-1/12" HEX BOLT	SWAY BAR
4	1/2 SAE WASHER	
2	M14-2.0 X 100MM HEX BOLT	
4	M14 WASHER	
2	M14-2.0 C-LOCK NUT	
12	7/16 SAE WASHER G8 ZINC	SWAY BAR
6	7/16-14 C-LOCK NUT ZINC	
6	7/16-14 X 1 1/4 HEX HD	
1	3/4" SAE WASHER	TRACK BAR PIN
2	3/4-16 C-LOCK NUT	TRACK BAR PIN
2	3/8-16 X 1" HEX BOLT	BRAKE LINE
4	3/8" SAE WASHER	
2	3/8-16 NYLOCK NUT	
2	1/4 SAE WASHER	
1	1/4-20 GR C CROWNLOCK NUT	
1	1/4-20 X 3/4 HEX BOLT G5 ZINC	
2	1/2-13 X 1-1/4 HEX BOLT	BUMP STOP
2	1/2-13 X 1-1/2 HEX BOLT	
6	1/2 SAE WASHER	
2	1/2-13 C-LOCK NUT	
1	COTTER PIN	
1	M12-1.75 X 70MM HEX BOLT	STEERING STABILIZER
2	M12 WASHER	
1	M12-1.75 C-LOCK	
1	9/16-12 NYLOCK NUT	
3	9/16 SAE WASHER	
4	3/4-10 X 5" HEX BOLT	4-LINK
4	3/4-10 X 1-1/2" HEX BOLT	
16	3/4" SAE WASHER	
8	3/4-10 C-LOCK NUT	
1	THREAD LOCKING COMPOUND 1 MIL	
1	HOSE CLAMP	

- TOOL LIST -

Required Tools (Not Included)

- Basic Hand Tools
- Assorted Metric and S.A.E sockets, and Allen wrenches
- Torque Wrench
- Die Grinder w/ Cutoff Wheel or Sawzall
- 1-1/4" Hole Saw
- Basic Hand Tools
- Floor Jack
- Jack Stands
- Drill
- Vise-Grip clamps

- PRE-INSTALLATION NOTES -

For technical assistance call: **909-597-7800** or e-mail: **info@fabtechmotorsports.com**

READ THIS BEFORE YOU BEGIN INSTALLATION -

Check all parts to the parts list above before beginning installation. If any parts are missing contact Fabtech at 909-597-7800 and a replacement part will be sent to you immediately.

Read all instructions thoroughly from start to finish before beginning the installation. If these instructions are not properly followed severe frame, driveline and / or suspension damage may occur.

Check your local city and state laws prior to the installation of this system for legality. Do not install if not legal in your area.

Prior to the installation of this suspension system perform a front end alignment and record. Do not install this system if the vehicle alignment is not within factory specifications. Check for frame and suspension damage prior to installation.

The installation of this suspension system should be performed by two professional mechanics.

This suspension must be installed with Fabtech shock absorbers.

Use the provided thread locking compound on all hardware.

WARNING- Installation of this system will alter the center of gravity of the vehicle and may increase roll over as compared to stock.

Vehicles that receive oversized tires should check ball joints, uniballs, tie rods ends, pitman arm and idler arm every 2500-5000 miles for wear and replace as needed.

Verify differential fluid is at manufactures recommended level prior to kit installation. Installation of the kit will reposition the differential and the fill plug hole may be in a different position. (For example, if the manufacture recommends 3 quarts of fluid, make sure the diff has 3 quarts of fluid). Check your specific manual for correct amount of fluid.

Recommend Tires and Wheels:

- Use 37/12.50R18 tire w/ 18x9 wheels w/ 4-3/4" BS w/ required fender well trimming
- Use 37/13.50R20 tire w/ 20x9 wheels w/ 5" BS w/ required fender well trimming

FOOTNOTES -

- NON DUALY MODELS ONLY
- WILL NOT FIT GAS MOTOR VEHICLES
- VEHICLES EQUIPPED WITH 2 PIECE REAR DRIVE SHAFT REQUIRE PART #FTS419
- SOME 2017 MODELS MAY REQUIRE A DUAL STEERING STABILIZER TO ADDRESS STEERING FEEDBACK. ORDER DIRT LOGIC-FTS220512, DIRT LOGIC W/RESI-FTS221162 OR STEALTH-FTS8046
- VEHICLES W/ FACTORY REAR SWAY BAR MUST ORDER EXTENDED SWAY BAR LINK KIT PART NUMBER FTS22276.
- FRONT DRIVESHAFT MODIFICATION IS REQUIRED OR ORDER DRIVESHAFT FTS92035

- INSTRUCTIONS -

FRONT SUSPENSION

1. Disconnect the negative terminal on the battery. Jack up the front end of the truck and support the frame rails with jack stands. **NEVER WORK UNDER AN UNSUPPORTED VEHICLE!** Remove the front tires.
2. Disconnect the sway bar end links from the axle. Disconnect the sway bar from the frame. Remove sway bar with the links still attached. Save hardware.
3. Disconnect the brake line from the frame and axle on both driver and passenger sides. Save hardware. **SEE FIGURES 1-2**



FIGURE 1 - STEP 3



FIGURE 2 - STEP 3

4. Remove the front shocks and discard, save hardware.
5. Lower the front axle allowing the springs to come free of tension and remove the coil springs. **EXERCISE EXTREME CAUTION WHEN WORKING WITH COIL SPRINGS UNDER LOAD!**
6. Disconnect the factory steering stabilizer from the frame mount. Remove the steering stabilizer frame bracket. Discard the frame bracket. Save all hardware.
7. Remove the drag link from the pitman arm. **Use care not to damage the threads on the drag link.**

8. Disconnect the trac bar from the frame bracket and axle. Remove the trac bar. Next, remove the trac bar bracket from the frame, save the original hardware.
9. Remove the factory pitman arm from the steering box using a large pitman arm puller and discard.
10. Install FT30122 (Pitman Arm) using the supplied FT30258 (Sector shaft nut). Torque to 350 ft-lbs. **NOTE: This is a one time only use nut. If remove, it must be discarded.**
11. Locate FT30767 (Track Bar Bracket). Attach to the frame using the original hardware in the same position. Torque bolts to 120 ft-lbs. **SEE FIGURES 3**



FIGURE 3 - STEP 11

12. Working from both sides of the truck, locate and remove the factory front bump stops. Remove and save the foam portion by pulling on the bump stop itself to free from the cup. Remove the factory mounting cup from the frame and discard the hardware. Drill out the center hole on the factory cup to 1/2". **SEE FIGURES 4-5**



FIGURE 4 - STEP 12

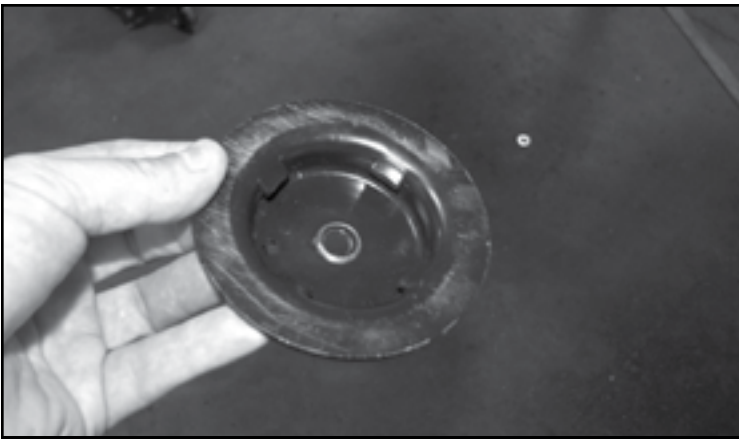

FIGURE 5 - STEP 12

13. Install FT30795 (Bump Stop Extension) onto the factory cup using the supplied 1/2" x 1-1/4" hardware and set aside. Torque to 127 ft-lbs. **SEE FIGURE 8**

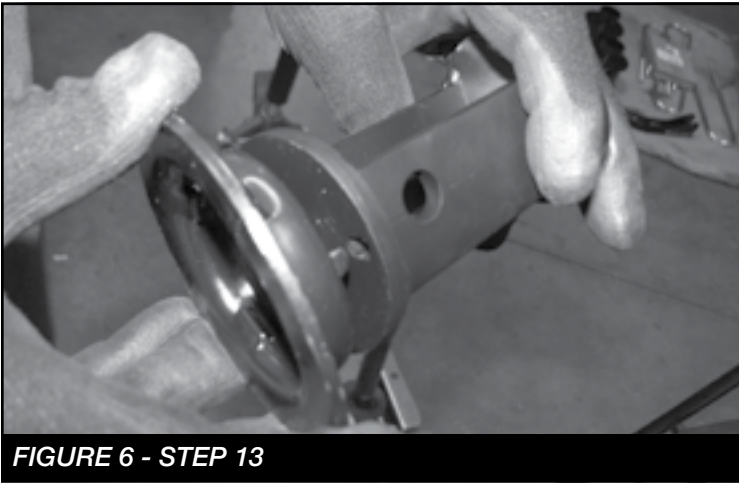

FIGURE 6 - STEP 13

14. Locate the factory bump stop mounting hole. Measure 3" straight up from the bottom of the frame. Mark and drill a 1-1/4" hole using a hole saw into the frame. **SEE FIGURES 7-8**

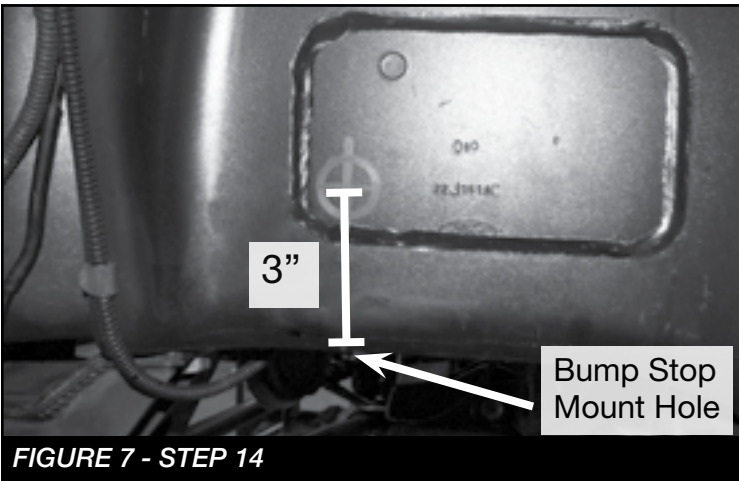

FIGURE 7 - STEP 14



FIGURE 8 - STEP 14

15. Drill out the factory bump stop mount hole to 1/2". **SEE FIGURE 9**

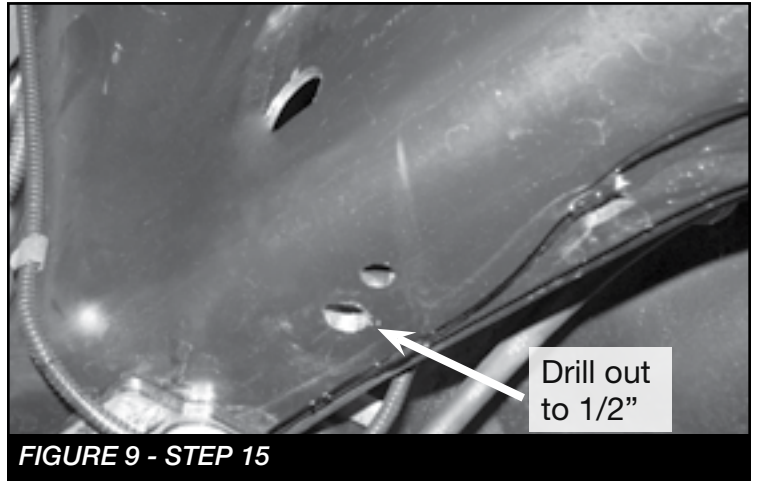

FIGURE 9 - STEP 15

16. Using FT50290 (Nut Tab) and 1/2 X 1-1/2" bolt and washer. Mount the new bump stop extension to the frame. Route the Nut tab through the 1-1/4" hole that was made in Step 14. Torque to 127 ft-lbs. **SEE FIGURE 10**

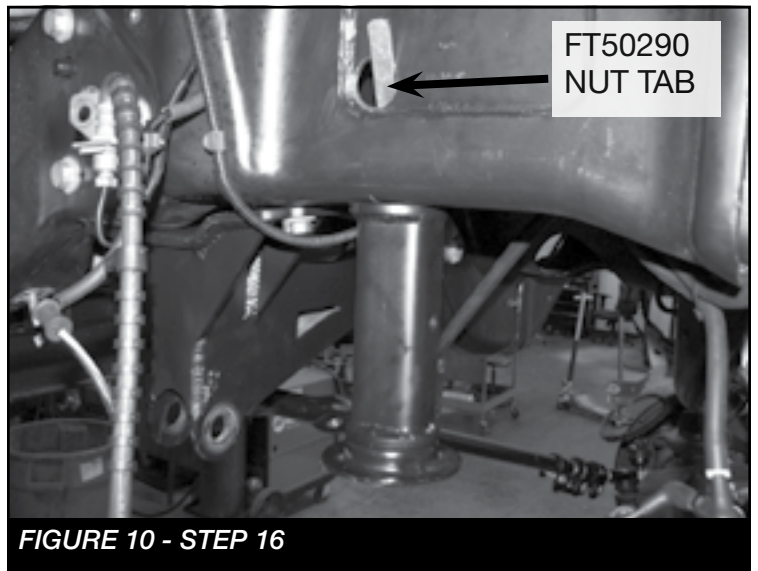

FIGURE 10 - STEP 16

REPEAT BUMP STOP INSTALLATION ON PASSENGER SIDE

17. Locate FT30698 (sway bar relocation nut tab). Beginning on the driver side of the vehicle. Measure forward 4-3/8" from the factory radius arm pocket and centered on the frame for your first mark. Using the FT30698 (dual nut tab), use the first hole and center up the tab and mark the second hole. Center punch then drill both holes to 1/2". **SEE FIGURES 11-12**

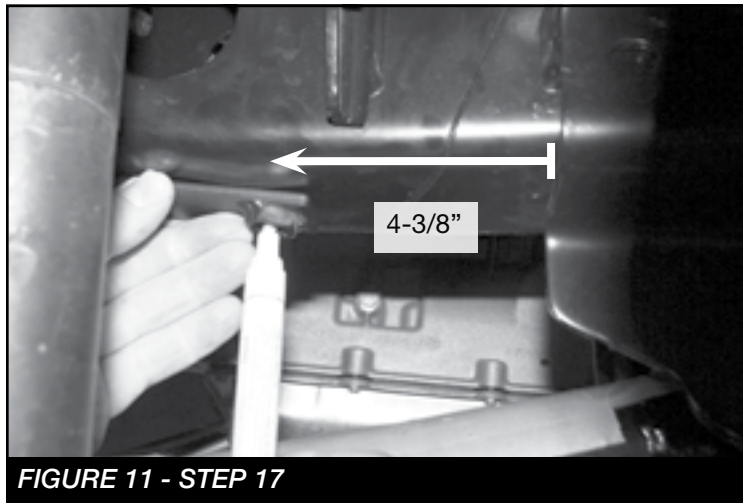

FIGURE 11 - STEP 17

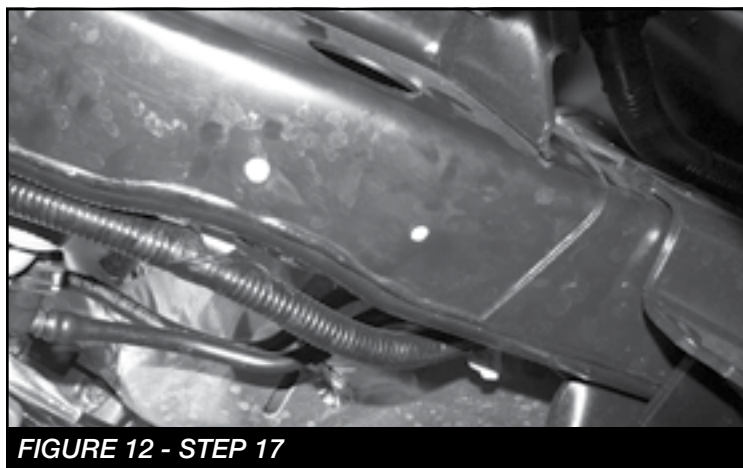

FIGURE 12 - STEP 17

- Repeat step 17 on the passenger side

18. Locate the factory sway bar. The factory bushing mounts will need to be moved inward about an inch. The end that does not slide will need to be disassembled due to a locator ring. Move the bushing and mount just inside the ring. **SEE FIGURES 13-14**

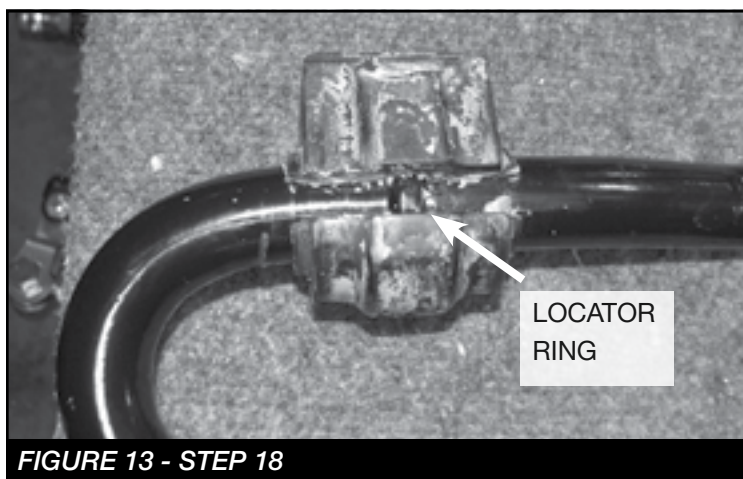

FIGURE 13 - STEP 18

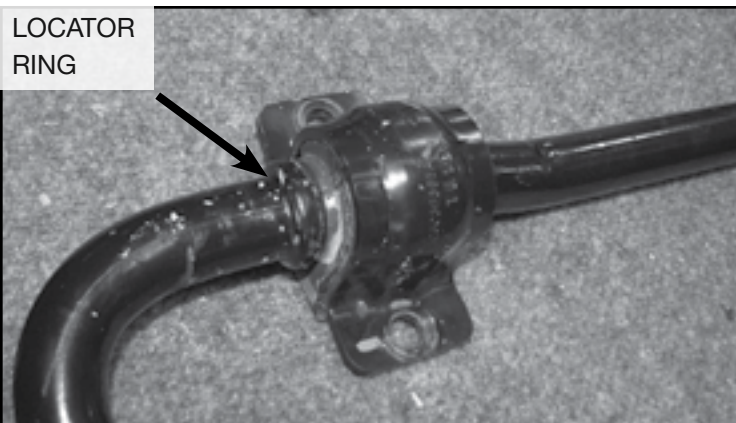

FIGURE 14 - STEP 18

19. Install FT30768 (Driver frame bracket) & FT30769 (Passenger frame bracket) using the FT30698 (nut tab) and 1/2" X 1-1/2" bolts, lock & flat washers. **NOTE:** Insert the nut tab through the factory hole on the side of the frame. Torque to 127 ft-lbs. **SEE FIGURES 15**

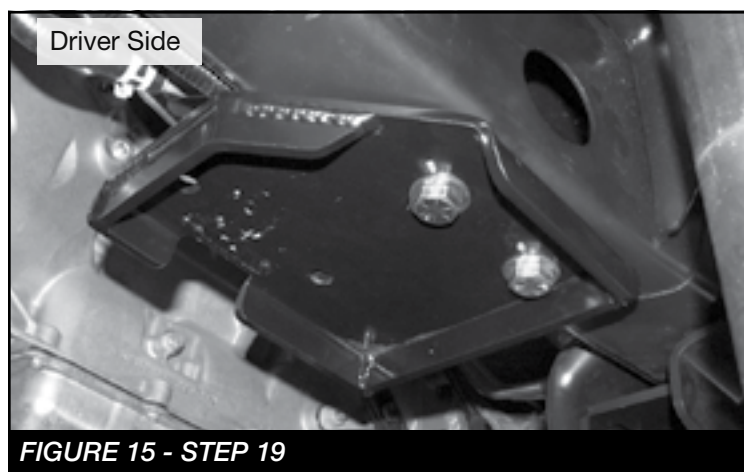

FIGURE 15 - STEP 19

20. Install the factory sway bar to the new brackets using the supplied 7/16" hardware. **NOTE: The bushing and mount may need to be moved slightly to line the sway bar up centered to the vehicle. SEE FIGURES 16.** Install FT30797 (clamp) on the passenger side of the sway bar up against the factory bushing to prevent movement. **SEE FIGURE 17**

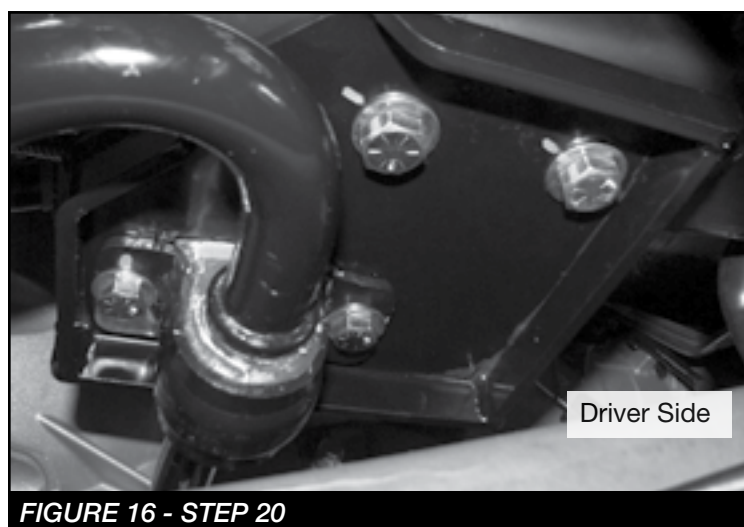

FIGURE 16 - STEP 20

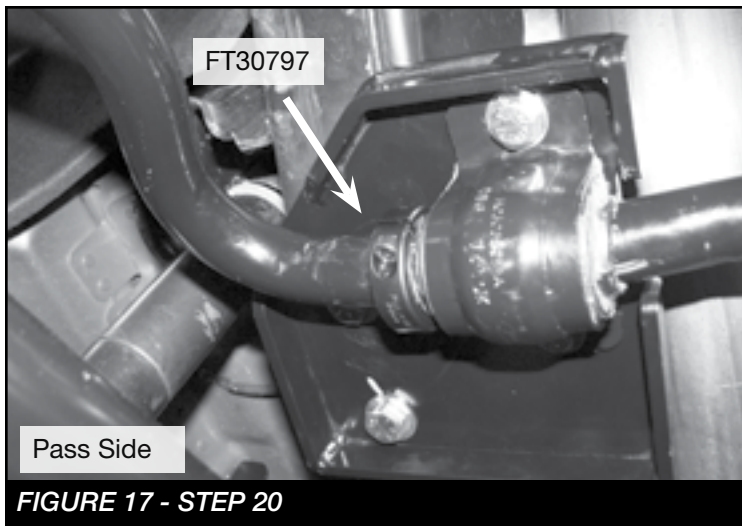

FIGURE 17 - STEP 20

21. With the front axle still supported by the floor jack, remove the Driver side factory radius arm.
22. Locate FT30650 (4-Link pocket). Install the bracket into the factory radius arm pocket using the supplied 3/4" x 1-1/2" bolts, nuts and washers through the original rear holes in the frame. Leave loose.
23. Locate FT30129BK (Lower Link) and (2) FT147 (Misalignments). Install the link into the new bracket "lower hole" using the supplied 3/4" X 5" Hardware. Install the FT292 (Alignment Cam kit) hardware at the axle side. Locate FT30692 (Upper Link) and (2) FT147 (Misalignments). Install the link into the new bracket forward upper hole" using the supplied 3/4" X 5" Hardware. Use the factory hardware at the axle mount. Torque 3/4" hardware to 380 ft-lbs, and factory axle bolts/alignment cams to 287 ft-lbs. **SEE FIGURES 18-19**

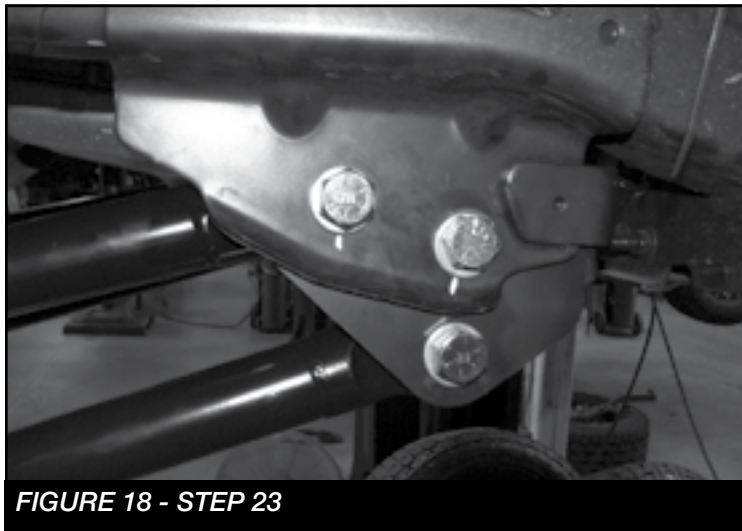

FIGURE 18 - STEP 23

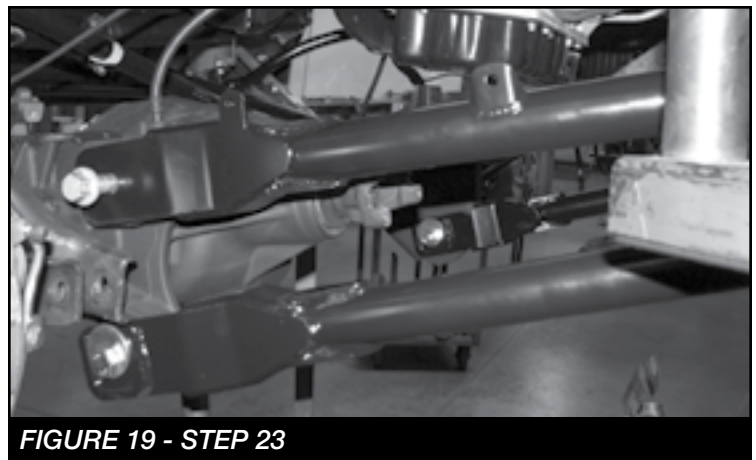

FIGURE 19 - STEP 23

- REPEAT STEPS 21-23 ON PASSENGER SIDE
 - **IF INSTALLING A COILOVER CONVERSION KIT, DO SO NOW AND SKIP TO STEP 27**
24. Install FT30124BK (Coil Spring) using the factory upper isolator. **SEE FIGURE 20**

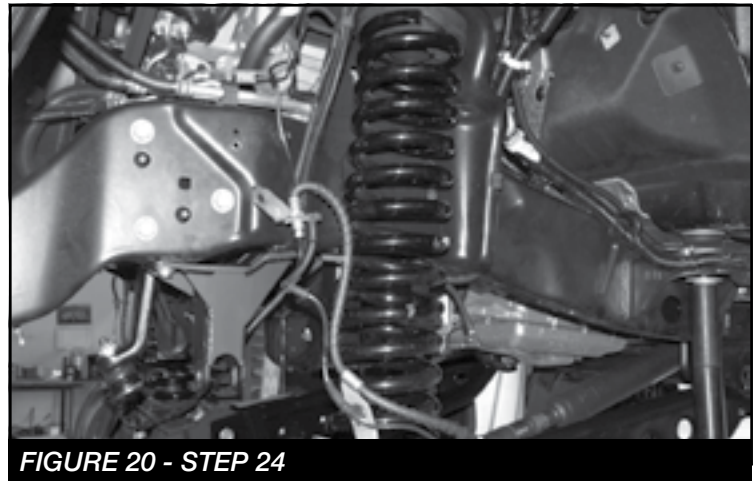

FIGURE 20 - STEP 24

25. Locate FT30770 (Axle sway bar bracket). Slide the bracket onto the lower shock mount and install the supplied 14mm hardware. Mark the forward hole. Remove the bracket and drill the marked hole to 7/16". **SEE FIGURES 21-22**

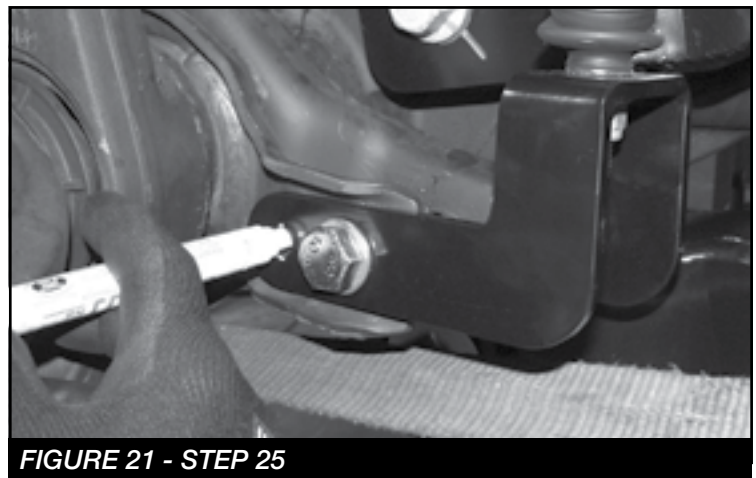

FIGURE 21 - STEP 25

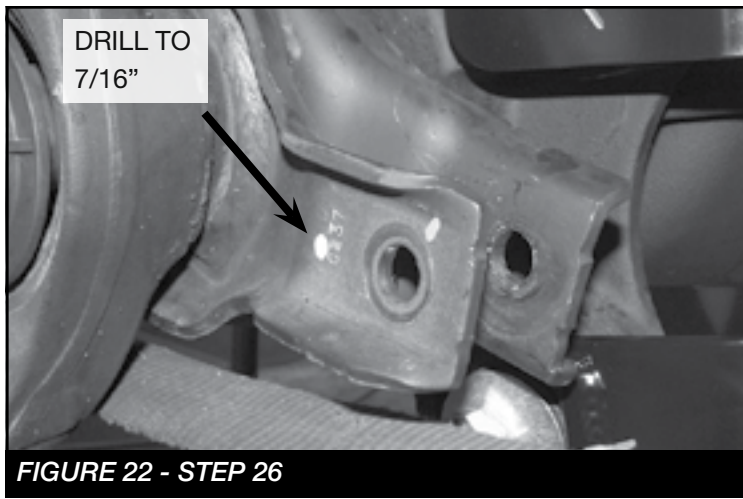

FIGURE 22 - STEP 26

26. Re-install the bracket using the supplied 7/16" x 1-1/4" & M14-2.0 X 100mm hardware with the new front shocks FTS800382 or FTS810382. **SEE FIGURE 23. NOTE: Install a supplied 9/16" washer at the lower mount to fill up the gap between the bushing and mount.** Install the sway bar end link to the new axle bracket at this time. Torque 7/16" hardware to 59 ft-lbs, factory to 127 ft-lbs, and sway bar end links to 52 ft-lbs.



FIGURE 23 - STEP 27

27. Locate FT30414 (Rod End) and install (2) FT30262-3 (Bushings) and FT30262-4 (Sleeve). Assemble the rod end to the FT30415 (Adjusting sleeve) & FT30782 (Track Bar). Preset the track bar assembly to 41.5" eye-to-eye. Install the new track bar to the axle mount using FT94510 (Adapter pin), FT30765 (spacer), (2) 3/4"-16 c-lock nuts and washer. **SEE FIGURE 24-25 FOR DIAGRAM AND INSTALLATION.** Torque to 150 ft-lbs.

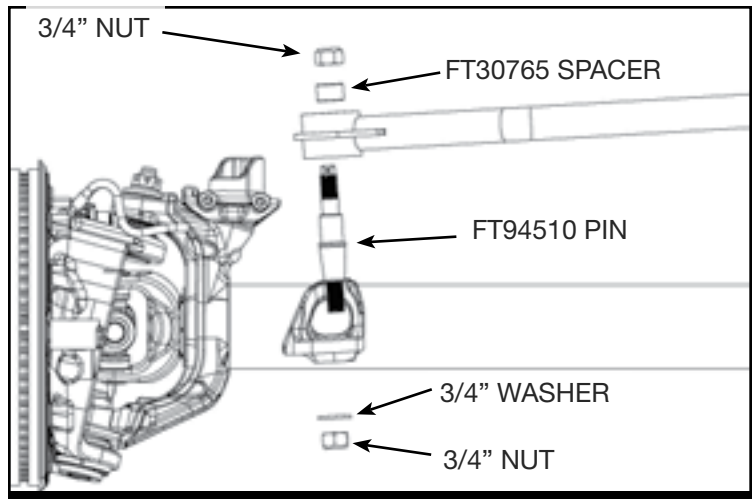

FIGURE 24 - STEP 27

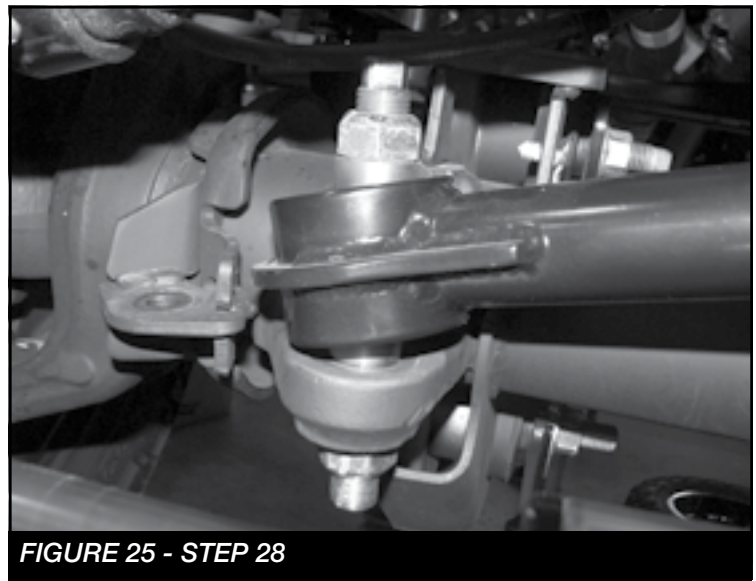

FIGURE 25 - STEP 28

28. Using (2) FT30786 (Washers). Install the track bar into the new Fabtech track bar using the factory bolt. Torque to 406 ft-lbs. **SEE FIGURE 26**

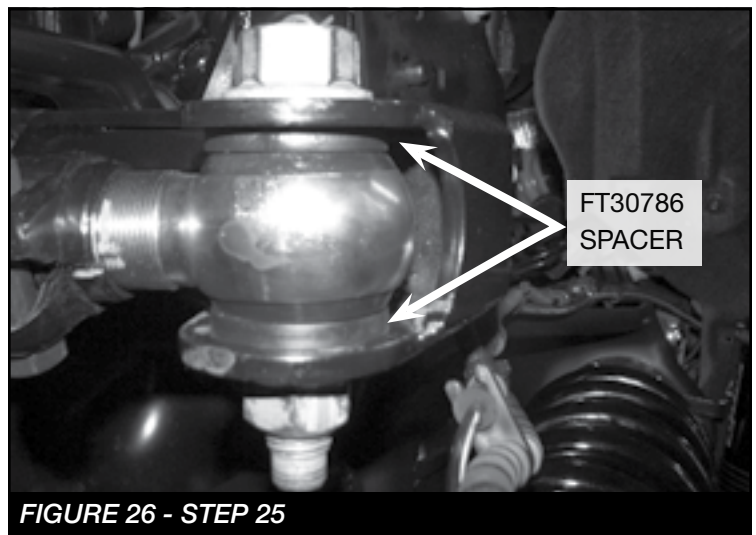
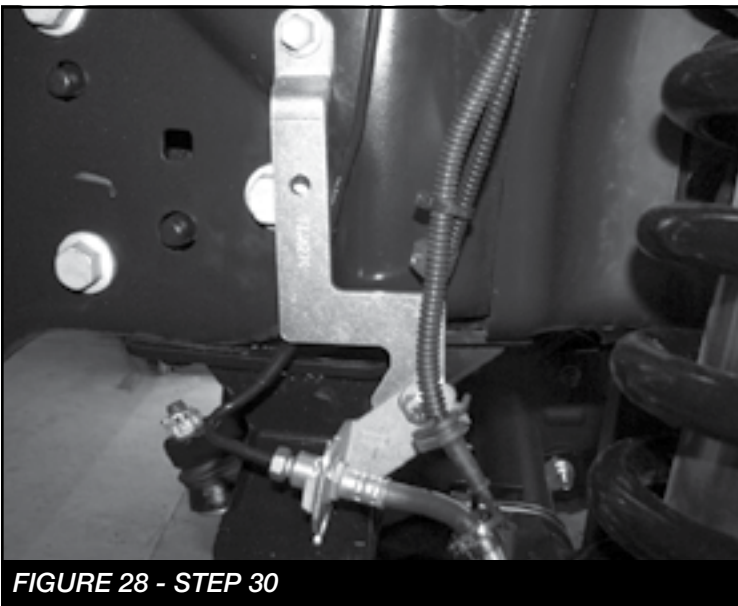
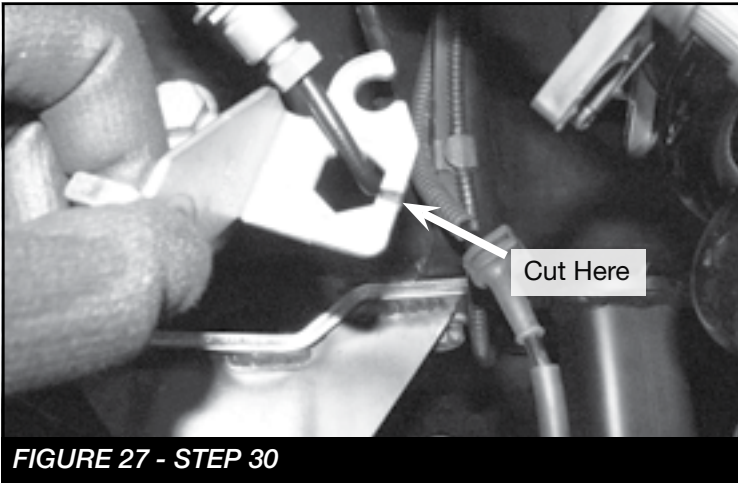

FIGURE 26 - STEP 25

29. Install the drag link to the new Fabtech pitman arm using the factory hardware and the new supplied cotter pin. **NOTE: The drag link will need to be rotated 180 degrees and installed from the bottom side of the pitman arm.**

30. **(DRIVER SIDE)** Remove the factory brake line bracket from the hard line by cutting a relief **SEE FIGURE 27**. Install FT30276 (Brake line bracket) to the factory location using the factory hardware. Install the factory bracket to the new Fabtech bracket using the supplied 3/8" X 1" hardware. Pull down on the brake line as well as bend the hard line and reconnect to the factory bracket. Torque hardware to 52 ft-lbs. **SEE FIGURE 28**



31. **(PASSENGER SIDE)** Install FT30276 (Brake line bracket) to the factory brake line tab using the supplied 3/8" hardware. Re attach to the frame using the factory hardware. Torque 3/8" & factory hardware to 52 ft-lbs. **SEE FIGURE 29**

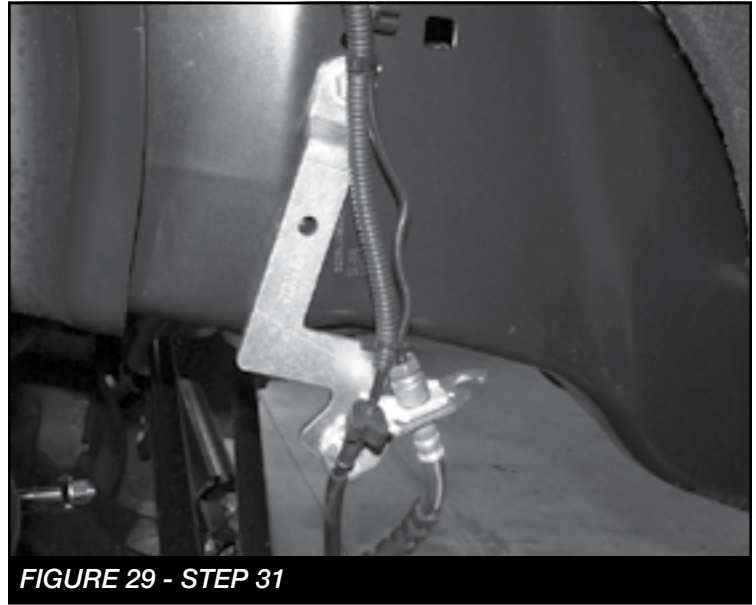

32. Install FT30672 (steering stabilizer drop bracket) in the factory location using the factory hardware. Torque to 52 ft-lbs. **SEE FIGURE 30**

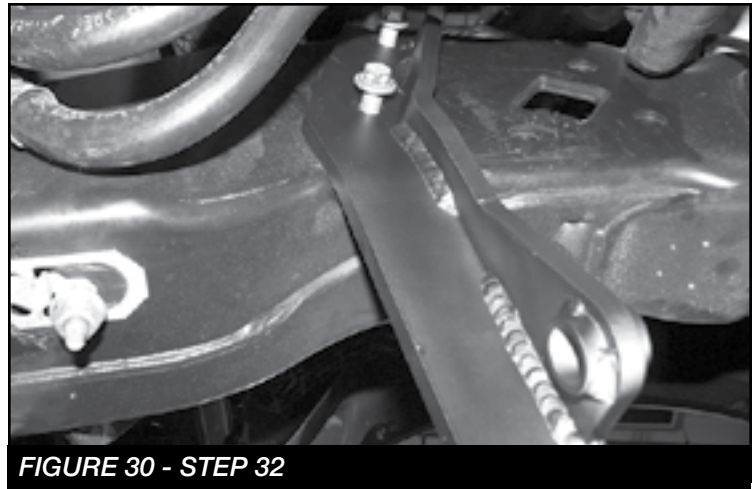

33. Install FT30686 (Stabilizer Clevis) on the factory steering stabilizer using the supplied M12-1.75 x 70mm hardware. **NOTE: Install FT30604 (spacer) like shown in the figure below.** Install the stabilizer using the supplied 9/16" washer and nut to the drag link. Using the factory hardware install the tapered end into the new Fabtech bracket. Torque to 127 ft-lbs. **SEE FIGURE 31**

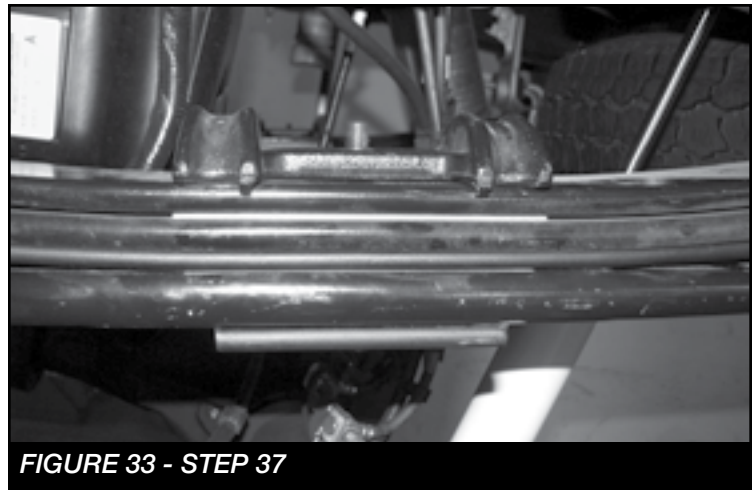
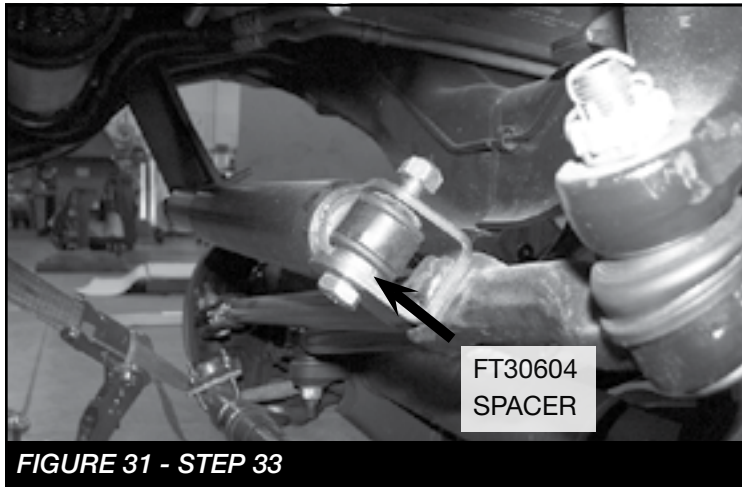

- FIGURE 33 - STEP 37**
38. Repeat Steps 36-37 on the passenger side.
39. Locate and install the rear lift blocks FTBK54D & P. The short end of the blocks should face to the front of the vehicle. Using the supplied u-bolts, nuts and washers align axle, lift blocks and springs and torque to U-Bolts to 170 ft-lbs. **SEE FIGURE 34**

34. Install the front tires and wheels. Torque lug nuts to wheel manufacturer's specifications.

REAR SUSPENSION

35. Jack up the rear end and remove the rear wheels. With the axle supported, remove the rear shocks, ubolts and blocks.
36. Driver side. Clamp the spring on either side of the center pin. Loosen and remove the center pin bolt.
37. Carefully remove the clamps and separate the leaves. Install the FT30781 (add a leaf) into the factory spring pack in a pyramid pattern smallest on the bottom to the longest on top. **NOTE: The FT30781 has a positioning hole which will line up with the roll pin located in the factory pack.** Install FT30284 (spring spacer) on the bottom of the pack and factory top plate. Next, insert the new FT90080 (center pin) through the pack and torque to 83 ft-lbs. **SEE FIGURE 32-33**

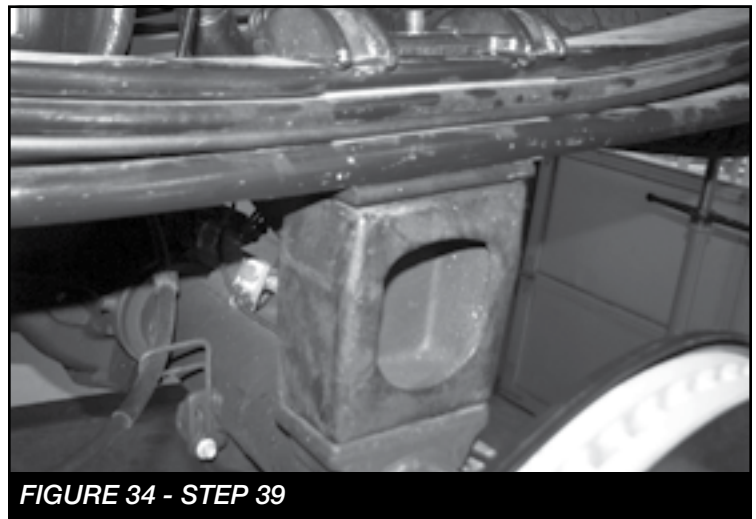

- FIGURE 34 - STEP 39**
40. Install the new rear shocks Dirt Logic FTS810052 using the factory hardware, torque the upper mount 46 ft-lbs. and the lower mount to 66 ft-lbs.
41. Install tires and wheels and torque lug nuts to wheel manufacturer's specifications. Turn front tires left to right and check for appropriate tire clearance. **Note - Some oversized tires may require trimming of the front bumper & valance.**
42. Check front end alignment and set to factory specifications. Readjust headlights.

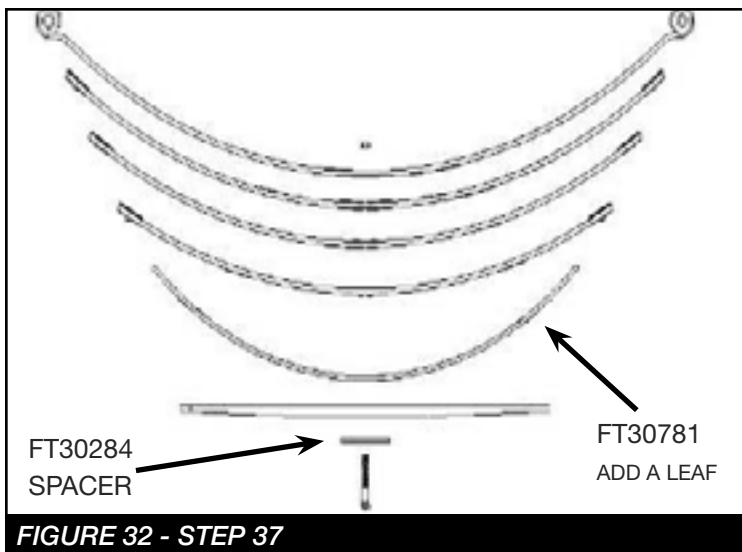

43. Recheck all bolts for proper torque.
44. Recheck brake hoses, ABS wires and suspension parts for proper tire clearance while turning tires fully left to right.
45. Check the fluid in the front and rear differential and fill if needed with factory specification differential oil. **Note - some differentials may expel fluid after filling and driving. This can be normal in resetting the fluid level with the new position of the differential/s.**
46. Install Driver Warning Decal. Complete product registration card and mail to Fabtech in order to receive future safety and technical bulletins on this suspension.

Vehicles that will receive oversized tires should check ball joints, uniballs and all steering components every 2500-5000 miles for wear and replace as required.

**RE-TORQUE ALL NUTS, BOLTS AND LUGS
AFTER 50 MILES AND PERIODICALLY
THEREAFTER.**

For technical assistance call: **909-597-7800**

- Product Warranty and Warnings -

Fabtech provides a Limited Lifetime Warranty to the original retail purchaser who owns the vehicle, on which the product was originally installed, for defects in workmanship and materials.

The Limited Lifetime Warranty excludes the following Fabtech items; bushings, bump stops, ball joints, tie rod ends, limiting straps, cross shafts, heim joints and driveshafts. These parts are subject to wear and are not considered defective when worn. They are warranted for 60 days from the date of purchase for defects in workmanship.

Dirt Logic and Performance Coilover take apart shocks are considered a serviceable shock with a one year warranty on leakage only. Service seal kits are available separately for future maintenance. All other shocks are covered under our Limited Lifetime Warranty.

Fabtech does not warrant any product for finish, alterations, modifications and/or installation contrary to Fabtech's instructions. Alterations to the finish of the parts including but not limited to painting, powder coating, plating and/or welding will void all warranties. Some finish damage may occur to parts during shipping, which is considered normal and is not covered under warranty.

Fabtech products are not designed nor intended to be installed on vehicles used in race applications or for racing purposes or for similar activities. (A "RACE" is defined as any contest between two or more vehicles, or any contest of one or more vehicle against the clock, whether or not such contest is for a prize). This warranty does not include coverage for police or taxi vehicles, race vehicles, or vehicles used for government or commercial purposes. Also excluded from this warranty are sales outside of the United States of America.

Installation of most suspension products will raise the center of gravity of the vehicle and will cause the vehicle to handle differently than stock. It may increase the vehicle's susceptibility to a rollover, on road and off road, at all speeds. Extreme care should be taken to operate the vehicle safely at all times to prevent rollover or loss of control resulting in serious injury or death. Fabtech front end Desert Guards may impair the deployment or operation of vehicles equipped with supplemental restraining systems/air bag systems and should not be installed if the vehicle is equipped as so.

Fabtech makes every effort to ensure suspension product compatibility with all vehicles listed on the website, but due to unknown auto manufacturer's production changes and/or inconsistencies by the auto manufacturer, Fabtech cannot be responsible for 100% compatibility, including the fitment of tire and wheel sizes listed. The Tire and Wheel sizes listed in Fabtech's website are only a guideline for street driving with noted fender trimming. Fabtech is not responsible for damages to the vehicle's body or tires. Fabtech is not responsible for premature wear of factory components due to the installation of oversized tires and wheels.

Fabtech's obligation under this warranty is limited to the repair or replacement, at Fabtech option, of the defective product only. All costs of removal, installation or re-installation, freight charges, incidental or consequential damages are expressly excluded from this warranty. Fabtech is not responsible for damages and/or warranty of other vehicle parts related or non related to the installed Fabtech product. This warranty is expressly in lieu of all other warranties expressed or implied. This warranty shall not apply to any product that has been subject to accident, negligence, alteration, abuse or misuse as determined by Fabtech.

Fabtech suspension components must be installed as a complete system including shocks as shown on our website. All warranties will become void if Fabtech parts are combined and/or substituted with other aftermarket suspension products. Combination and/or substitution of other aftermarket suspension parts may cause premature wear and/or product failure resulting in an accident causing injury or death. Fabtech does not warrant products not manufactured by Fabtech.

Depending on the condition of the factory suspension components retained after the installation of a Fabtech suspension not all vehicles may have the same ride stance front to rear as described in the website. The blue color of suspension components shown in all Fabtech photographs are for display purposes only. Majority of all Fabtech components will be black specifically where noted with part numbers ending in BK.

Installation of Fabtech product may void the vehicles factory warranty; it is the consumer's responsibility to check with their local vehicle's dealer for warranty disposition before the installation of the product. Some state laws may prohibit modification of suspension to a vehicle in whole or in part. It is the responsibility of the installer and consumer to consult local laws prior to the installation of any Fabtech suspension product to comply with such written laws.

It is the responsibility of the distributor and/or the retailer to review all warranties and warnings of Fabtech products with the consumer prior to purchase.

Fabtech reserves the right to super cede, discontinue, change the design, finish, part number and/or application of parts when deemed necessary without written notice. Fabtech is not responsible for misprints or typographical errors within the website or price sheet. For the most recent Product Warranty and Warnings visit our website www.fabtechmotorsports.com