



150 PSI ILLUMINATED DASH PANEL GAUGE KIT

- PART NO. 10061 (For Use with 20/30 Amp Systems)
- PART NO. 20062 (For Use with 30/40 Amp Systems)



IMPORTANT:

It is essential that you and any other operator of this product read and understand the contents of this manual before installing and using this product.

SAVE THIS MANUAL FOR FUTURE REFERENCE

USER MANUAL

150 PSI Illuminated Dash Panel Gauge Kit

Please read this instruction manual carefully prior to operating this product. Pay particular attention to the **CAUTION** and **WARNING** statements in this manual. Failure to comply with these instructions could result in personal injury or property damage. Retain these instructions for future reference.

PARTS LIST:

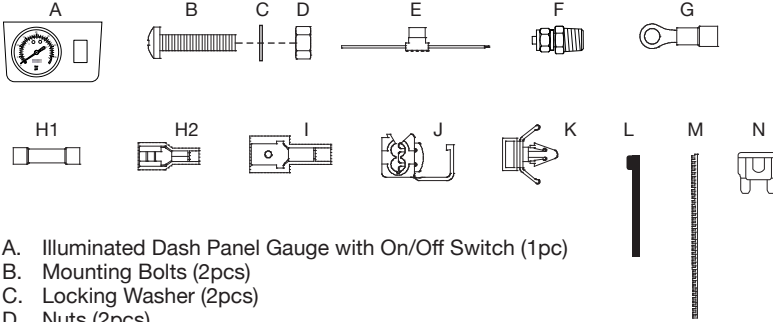

- A. Illuminated Dash Panel Gauge with On/Off Switch (1pc)
- B. Mounting Bolts (2pcs)
- C. Locking Washer (2pcs)
- D. Nuts (2pcs)
- E. 20 Ft. Extension Lead Wire with Inline Fuse / Fuse Holder (1pc)
- F. 1/8" (F) NPT Compression Fitting for 1/4" O.D. Air Line (1pc)
- G. Ring Terminals (3pcs)
- H1. Insulated Female Terminal Connectors (2pcs)
- H2. Insulated Female Terminal Connector (1pc)
- I. Insulated Male Terminal Connectors (2pcs)
- J. Quick Splice Connectors (2pcs)
- K. Cable Tie Brackets (3pcs)
- L. Cable Ties (6pcs)
- M. Continuous Grommet (1pc)
- N. Fuse (2pcs)*

*20 Amp Fuse & 30 Amp Fuse (P/N: 10061) or 30 Amp Fuse & 40 Amp Fuse (P/N: 20062)

INSTALLATION INSTRUCTIONS:

CHECK FOR CORRECT GAUGE KIT: The Illuminated Dash Panel Gauge Kit (P/N 10061) was designed for Onboard Air Installation with our 90-100 Series Air Compressors. The Illuminated Dash Panel Gauge Kit (P/N 20062) was designed for Onboard Air Installation with our 200-400 Series Air Compressors. **Please make sure that you have the correct Gauge Kit.**

For installation to compressors/systems other than VIAIR components, please find out the Maximum Amp Draw of your compressor and refer to the following chart:

Compressor Max. Amp Draw	VIAIR Illuminated Dash Panel Gauge Kit
20 Amp	P/N 10061
30 Amp	P/N 20062

IMPORTANT: The Illuminated Dash Panel Gauge has been fully function tested and calibrated for accuracy. The air inlet on this gauge has a factory installed compression fitting. **DO NOT ATTEMPT** to tighten or loosen the body of this compression fitting. Any adjustments will likely cause the gauge to malfunction and void warranty. (See Fig. 3)

NOTE: The Illuminated Dash Panel Gauge included in this kit is rated for 150 PSI. **DO NOT** pressurize gauge to more than 150 PSI. Over-pressurization will cause the gauge to malfunction and void warranty.

150 PSI Illuminated Dash Panel Gauge Kit

STEP BY STEP INSTALLATION:

1. Select mounting location with a rigid mounting surface such as the bottom edge of the dashboard on either side of the steering wheel column. Use the gauge mounting panel as a template to mark off two mounting points to be drilled. Drill two 13/64" diameter holes as marked. Do not mount Gauge at this time.

NOTE: If you have existing 1/4" O.D. air line tubing routed, cut off a 1/2" to 1" section of air line tubing from the tip of your existing air line before connecting the air line to the gauge as to ensure that you have a fresh air line tip for connection.

2. If you do not have a pre-existing 1/4" O.D. air line, measure the length of the air line required to route from Gauge to Air Source. Use a length of 1/4" O.D. air line that is at least the length you just measured. Do not cut your air line at this time. Remove only the collar of the compression fitting from the back of the Dash Panel Gauge. **DO NOT loosen or tighten the body of the compression fitting which is permanently affixed to the air inlet of the gauge.** Insert the 1/4" O.D. air line through the compression fitting collar, then push air line onto the barb of the compression fitting until the air line completely covers the barb. Tighten collar to the body of the compression fitting with wrench. *(See Fig. 1)*

NOTE: When cutting air line, cut as squarely as possible. Use a hose cutter or razor blade. To ease insertion of air line tubing into fittings, lightly lubricate the tip of the air line or soak air line in warm water for about 5 minutes to soften the air line. When routing air line, always remember to avoid sharp edges, heat source, and tight bends. **Air line must be routed at least 12" away from exhaust systems.**

3. Temporarily place Dash Panel Gauge at mounting location and route the air line tubing on the Dash Panel Gauge to your air source. (In a typical setup, your air source will be the air tank). Measure and cut air line to appropriate length, connect air line to air source using the provided 1/8" (F) NPT compression fitting. *(See Fig. 3 & 4)*

NOTE: In some cases, a hole may be required to be drilled in the firewall to enable the air line and/or wire to pass through the firewall to air and power sources. Make sure that the air line tubing and wire is protected from sharp edges of the drilled hole.

A continuous grommet strip is included in your kit. Seat grommet strip around the edge of the hole, measure and cut strip to appropriate length. Work the strip around the hole opening until the slot in the grommet strip sits firmly all the way around the edge of the hole. It will be necessary to seal any grommets or holes that have been cut or drilled so as to seal off the elements from entering the cab area of your vehicle. Use cable ties, air line clips, and/or cable tie brackets to secure air line and/or wire to the vehicle.

IMPORTANT: Drilling through the firewall, always make sure what is on the other side of the firewall before drilling. Make sure not to damage your vehicle's electronic systems/components when drilling.

4. The Illuminated Dash Panel Gauge comes with a built-in On/Off Switch, which is to be connected to your pressure switch via the provided 20 Ft. lead wire. *(See Fig. 3 & 4)* Your pressure switch should be connected to your relay and Dash Panel Gauge On/Off switch.

There are three insulated female terminal connectors included in your kit. If your pressure switch has spade type push on connectors, attach the larger female terminal connector to one end of the provided 20 Ft. extension lead wire (the end without the inline fuse). To connect 20 Ft. extension lead wire to your pressure switch, simply push female terminal connector onto the spade connector on your pressure switch. If your pressure switch has lead wires instead of spade type connectors, simply attach provided insulated male terminal connector to your pressure switch lead wire. Connect 20 Ft. extension lead wire by pushing the female terminal connector onto the male terminal connector. *(See Fig. 3 & 4)*

150 PSI Illuminated Dash Panel Gauge Kit

5. Route 20 Ft. extension lead wire from pressure switch to the Dash Panel Gauge. Measure and cut lead wire to appropriate length. Do not discard the remaining length of the wire which has the inline fuse. This remaining length of wire with the inline fuse is called the power wire.
6. Place Dash Panel Gauge under dash over the two holes that were drilled by using the provided screws, nuts, and washers provided (mount the Dash Panel Gauge to the dash).
7. Attach one of the two smaller female terminal connectors to the extension lead wire that was routed from the pressure switch. There are two male spade connectors on the back of the On/Off switch. Connect the female terminal connector on the extension lead wire to the male spade connectors on the On/Off switch. **(See Fig. 4)** Next, attach an appropriate size ring terminal provided to the end of the power wire with the inline fuse. **This means the ring terminal will now be about 12" from the inline fuse.** Temporarily position the ring terminal at the power source and route power wire from the power source to the Dash Panel Gauge, measure and cut power wire to appropriate length. Remove power wire from power source. Next, attach the remaining smaller female terminal connector to the end of the power wire and connect to the remaining male spade connector on the On/Off switch. **(See Fig. 4)**

NOTE: Do not connect gauge to power source at this time.

8. There are two wires, one red and one black connected to the light bulb of the gauge. Connect the red wire to a sustainable fused dash panel circuit. Use the quick splice connector provided for wire connection. **(See Fig. 2)** for how to use the quick splice connector. The black wire is to be connected to a suitable ground source. Use the ring terminal or the quick splice connector for ground wire connection.

NOTE: Consult vehicle manufacturer's electrical diagram.

To use the quick splice connector, simply insert wire into one hole of the splice connector and slip the connecting wire into the other hole. Once the wires are properly placed, close the top of the quick splice connector. The connector will pierce wire insulation to complete wire connection. **(See Fig. 2)**

9. Before connecting the power wire to power source, check to make sure that the On/Off switch on the Dash Panel Gauge is in the Off position. Connect the ring terminal of the power wire to power source.
10. Your illuminated Dash Panel Gauge installation is now completed. Run your compressor a short time to build up pressure in air tank. Inspect all air line connections for leaks with soap and water solution. If a leak is detected, the air line may not be cut squarely or pushed all the way in. Tighten connections if needed.

OPERATING INSTRUCTIONS:

1. Your Dash Panel Gauge comes with an On/Off power switch. This feature allows you to shut off power to the air compressor when compressor operations are not required.
2. Your Dash Panel Gauge is rated for maximum 150 PSI working pressure. Do not use gauge on systems with pressure rating higher than 150 PSI.

Fig. 1

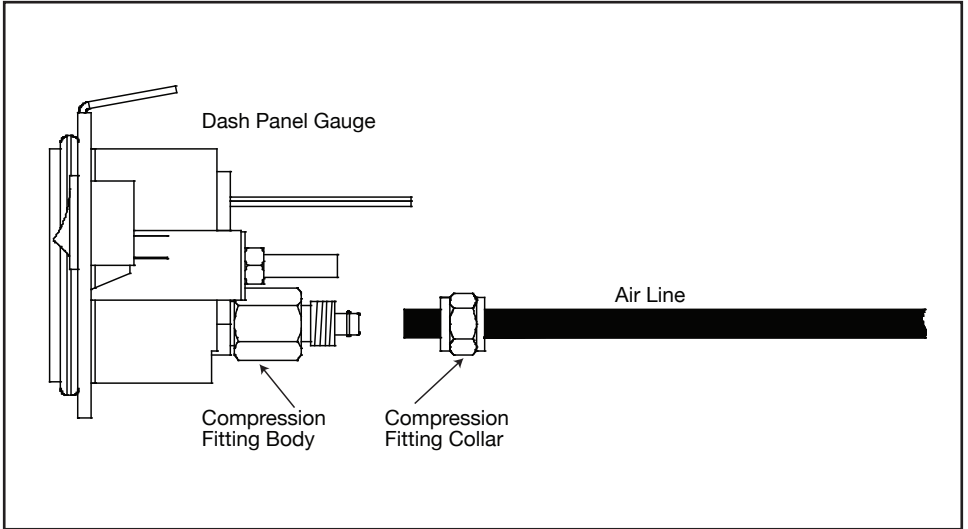
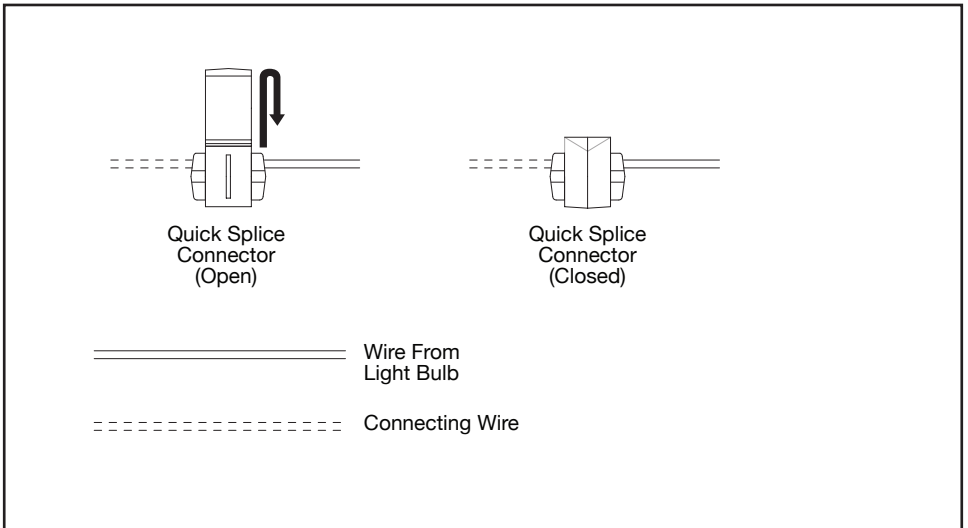

Fig. 2



150 PSI Illuminated Dash Panel Gauge Kit

Fig. 3

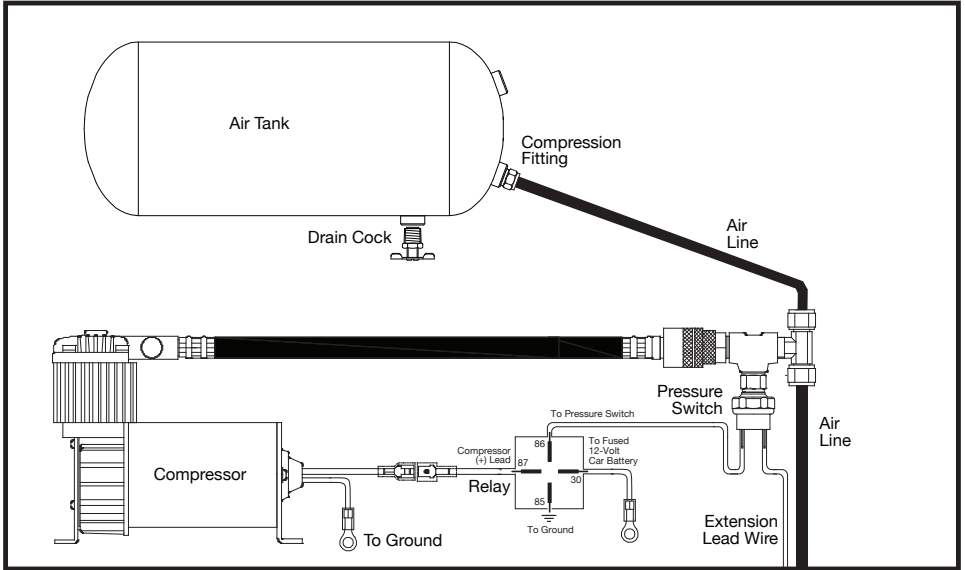
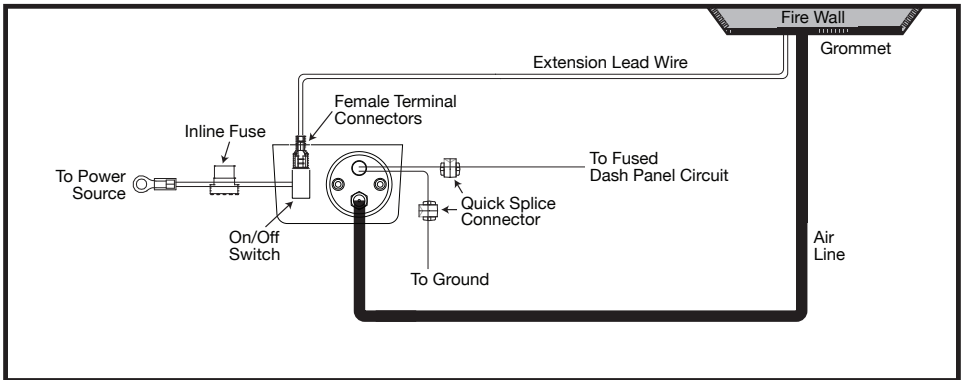

Fig. 4



LIMITED WARRANTY:

VIAIR Corporation warrants this product, when properly installed and under normal conditions of use, to be free from defects in workmanship and materials for a period of one year from its original date of purchase. To receive warranty service or repair, please contact VIAIR Corporation.

Returns should be made within one year of the date of purchase, after a Return Goods Authorization (RGA) number has been assigned by VIAIR Corporation. To obtain RGA, fax a copy of your receipt to (949) 585-0188. For complete warranty details, please visit: www.viaircorp.com/warranty

PLEASE NOTE:

THIS WARRANTY COVERS PRODUCT DEFECTS ONLY; IT DOES NOT COVER INCIDENTAL OR CONSEQUENTIAL DAMAGES AS RESULT OF MISUSE OR ABUSE.



15 EDELMAN • IRVINE, CA 92618
TEL: (949) 585-0011 • FAX: (949) 585-0188
www.viaircorp.com