



YOSHIMURA

RESEARCH&DEVELOPMENT OF AMERICA, INC.

5420 DANIELS STREET STE A, CHINO CA., 91710 · (800)634-9166 · (909)628-4722 · FACSIMILE (909)591-2198

www.yoshimura-rd.com

YOSHIMURA PERFORMANCE EXHAUST SYSTEM

KAWASAKI
2008-2012
VERSYS 650

1435272	STAINLESS STEEL SLIP-ON WITH CARBON FIBER TRC
1435275	STAINLESS STEEL SLIP-ON WITH STAINLESS STEEL TRC AND CF ENDCAP
1435277	STAINLESS STEEL SLIP-ON WITH TITANIUM SLEEVE AND CF ENDCAP



THIS PRODUCT IS DESIGNED FOR USE IN CLOSED COURSE RACING AND IS NOT INTENDED FOR HIGHWAY USE.



NOTE: IN THE STATE OF CALIFORNIA, IT IS ILLEGAL TO MODIFY THE EMISSION CONTROL SYSTEM, WHICH INCLUDES THE FUEL INJECTION OF ANY VEHICLE.

Caution: Exhaust system can be extremely hot. Let motorcycle cool down before beginning installation. Always wear hand and eye protection and take precautionary measures to avoid injury.

Note: Read through all instructions before beginning installation.

Tools Needed:

Metric Socket Set
Ratchet and Extension
Metric Combination Wrench Set
Metric Allen Wrench Set
Torque Wrench

Installation Steps:

1. Remove stock system.
 - Loosen muffler clamp.
 - Remove header bolts.
 - Remove header bolts and remove header.
Note: Header must be removed to provide clearance for stock muffler removal.
 - Remove plastic right rearsset cover and rearsset.
 - Remove the muffler mounting two bolts.
 - Remove stock muffler.
2. Install Yoshimura Slip-on
 - Reinstall stock header.
 - Reinstall rearsset and rearsset cover.
 - Insert rubber grommet and spacer into Yoshimura bracket. (See parts diagram for orientation.)
 - Remove rear master cylinder bolts.
 - Insert Yoshimura bracket between the rearsset and master cylinder.
Bolt together using stock bolts. Torque to 12 lb-ft (16.5 N-m).
 - Insert supplied collector clamp over Yoshimura tailpipe.
 - Install muffler using supplied bolt and washer.
 - Torque muffler clamp to 14 lb-ft (18.5 N-m).
 - Torque muffler mounting bolt to 18 lb-ft (23.5 N-m).
3. Check for proper clearance between new exhaust system and motorcycle. (i.e. Swing-arm, body work, etc.) If any problem is found, please carefully follow through the installation steps again. If problem still persists, please call Yoshimura technical department at (800)634-9166 / in CA (909)628-4722.

Note: After starting motorcycle, it is normal for new exhaust system and muffler to smoke until oil residue burns off.



Fig. 1

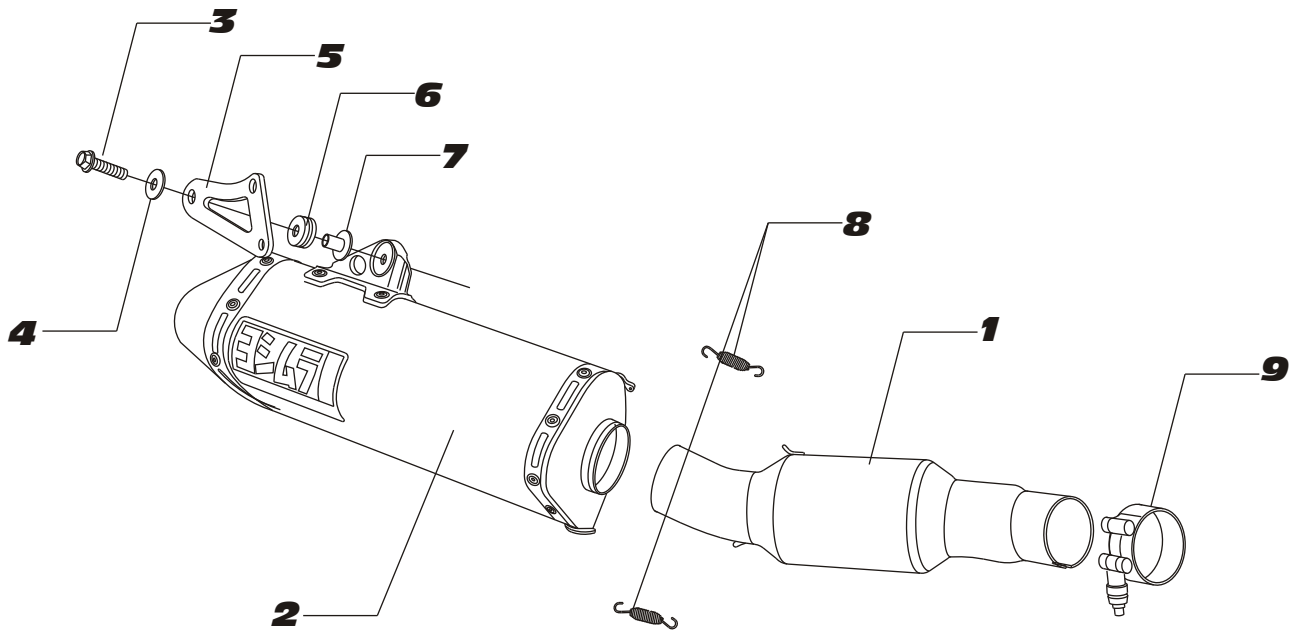

Fig. 2

#143527(2,5,7)**S=STOCK**

Parts Diagram

NO.	DESCRIPTION	QTY	PART #
1	Yoshimura Tailpipe	1	1435-435
2	Yoshimura TRC Muffler with Carbon Fiber TRC with Stainless Steel TRC with Titanium TRC	1	1435272-RMA 1435275-RMA 1435277-RMA
3	8mm X 25mm Flanged Hex Head Bolt	1	M8X25H
4	8mm Washer Large	1	8MMWASHERL
5	1435 Muffler Bracket	1	1435-BKT
6	Rubber Grommet	1	Z1022
7	Aluminum Spacer	1	ALS-003
8	Small Exhaust Spring	2	RACE-SPX-1
9	Exhaust Collector Clamp	1	22059
**	Spring Puller Tool	1	ST-200
**	Low Volume Insert	1	TRC-INS-K
**	Yoshimura Vinyl Sticker	1	17029