

**Instruction 51-1193
04-30-10**

Copyright © 2005, 2006, 2010
by S&S® Cycle, Inc.

All rights reserved.
Printed in the U.S.A.

S&S® Cycle, Inc.

14025 Cty Hwy G PO Box 215

Viola, Wisconsin 54664

Phone: 608-627-1497 • Fax: 608-627-1488

Technical Service Phone: 608-627-TECH (8324)

Technical Service Email: sstech@sscyle.com

Website: www.sscyle.com



Installation Instructions: S&S® Rocker Boxes for 1966-'84 Big Twin

DISCLAIMER:

S&S parts are designed for high performance, closed course, racing applications and are intended for the very experienced rider only. The installation of S&S parts may void or adversely affect your factory warranty. In addition such installation and use may violate certain federal, state, and local laws, rules and ordinances as well as other laws when used on motor vehicles used on public highways, especially in states where pollution laws may apply. Always check federal, state, and local laws before modifying your motorcycle. It is the sole and exclusive responsibility of the user to determine the suitability of the product for his or her use, and the user shall assume all legal, personal injury risk and liability and all other obligations, duties, and risks associated therewith.

The words Harley®, Harley-Davidson®, H-D®, Sportster®, Evolution®, and all H-D part numbers and model designations are used in reference only. S&S Cycle is not associated with Harley-Davidson, Inc.

SAFE INSTALLATION AND OPERATION RULES:

Before installing your new S&S part it is your responsibility to read and follow the installation and maintenance procedures in these instructions and follow the basic rules below for your personal safety.

- Gasoline is extremely flammable and explosive under certain conditions and toxic when breathed. Do not smoke. Perform installation in a well ventilated area away from open flames or sparks.
- If motorcycle has been running, wait until engine and exhaust pipes have cooled down to avoid getting burned before performing any installation steps.
- Before performing any installation steps disconnect battery to eliminate potential sparks and inadvertent engagement of starter while working on electrical components.
- Read instructions thoroughly and carefully so all procedures are completely understood before performing any installation steps. Contact S&S with any questions you may have if any steps are unclear or any abnormalities occur during installation or operation of motorcycle with a S&S part on it.
- Consult an appropriate service manual for your motorcycle for correct disassembly and reassembly procedures for any parts that need to be removed to facilitate installation.
- Use good judgment when performing installation and operating motorcycle. Good judgment begins with a clear head. Don't let alcohol, drugs or fatigue impair your judgment. Start installation when you are fresh.
- Be sure all federal, state and local laws are obeyed with the installation.
- For optimum performance and safety and to minimize potential damage to carb or other components, use all mounting hardware that is provided and follow all installation instructions.
- Motorcycle exhaust fumes are toxic and poisonous and must not be breathed. Run motorcycle in a well ventilated area where fumes can dissipate.

IMPORTANT NOTICE:

Statements in this instruction sheet preceded by the following words are of special significance.



WARNING

Means there is the possibility of injury to yourself or others.



CAUTION

Means there is the possibility of damage to the part or motorcycle.

NOTE

Other information of particular importance has been placed in italic type.

S&S recommends you take special notice of these items.

WARRANTY:

All S&S parts are guaranteed to the original purchaser to be free of manufacturing defects in materials and workmanship for a period of twelve (12) months from the date of purchase. Merchandise that fails to conform to these conditions will be repaired or replaced at S&S's option if the parts are returned to us by the purchaser within the 12 month warranty period or within 10 days thereafter.

In the event warranty service is required, the original purchaser must call or write S&S immediately with the problem. Some problems can be rectified by a telephone call and need no further course of action.

A part that is suspect of being defective must not be replaced by a Dealer without prior authorization from S&S. If it is deemed necessary for S&S to make an evaluation to determine whether the part was defective, a return authorization number must be obtained from S&S. The parts must be packaged properly so as to not cause further damage and be returned prepaid to S&S with a copy of the original invoice of purchase and a detailed letter outlining the nature of the problem, how the part was used and the circumstances at the time of failure. If after an evaluation has been made by S&S and the part was found to be defective, repair, replacement or refund will be granted.

ADDITIONAL WARRANTY PROVISIONS:

- (1) S&S shall have no obligation in the event an S&S part is modified by any other person or organization.
- (2) S&S shall have no obligation if an S&S part becomes defective in whole or in part as a result of improper installation, improper maintenance, improper use, abnormal operation, or any other misuse or mistreatment of the S&S part.
- (3) S&S shall not be liable for any consequential or incidental damages resulting from the failure of an S&S part, the breach of any warranties, the failure to deliver, delay in delivery, delivery in non-conforming condition, or for any other breach of contract or duty between S&S and a customer.
- (4) S&S parts are designed exclusively for use in Harley-Davidson® and other American v-twin motorcycles. S&S shall have no warranty or liability obligation if an S&S part is used in any other application.

INTRODUCTION

S&S® billet rocker covers are two-piece style assemblies designed to fit most big twin shovelhead engines that accept style rocker covers.

S&S rocker covers are machined from billet aluminum, and then polished to a show quality finish. O-ring sealing insures reliable, leak free operation.

NOTE: Plain, unpolished versions are available for custom applications. They may be powdercoated or otherwise finished to individual specifications. S&S plain billet aluminum rocker covers must be inspected, and burrs and sharp edges carefully removed by customer before installation.

S&S rocker covers are designed to accept S&S, or stock rocker arms. In most instances, they will accept valve lifts to .590" without modification.



Picture 1

NOTE: It remains engine builder's responsibility to check operating clearances. Clearances should be checked between valve spring/collar and rocker cover base as well as between rocker arm and top rocker cover. S&S recommends minimum of .060". Cylinder head must also be set up for correct lift.



CAUTION

Failure to establish correct operating clearances can result in extensive engine damage not covered under warranty.

S&S rocker covers are compatible with both stock (external) and S&S (pushrod) upper end oiling.

NOTE: In certain circumstances, S&S rocker covers can be installed and removed without removing the head.



CAUTION

S&S tappets and tappet block components for shovelheads are 1984-1999 design.

INSTALLATION

1. Wash motorcycle, taking care to remove sand and other abrasive debris from engine and area of frame around engine. Remove battery, gas tanks, and all parts required to access original rocker covers. Refer to authorized Harley-Davidson® Service Manual as necessary.



WARNING

Sparks from motorcycle electrical system can ignite gasoline fumes. To prevent sparks as well as prevent electric starter from becoming engaged inadvertently and causing personal injury, disconnect battery and remove from motorcycle before proceeding. Gasoline is toxic if fumes are inhaled, extremely flammable, and explosive under certain conditions. Do not smoke around gasoline, and perform installation in a well ventilated area away from sparks and open flame.

2. Remove pushrod cover retainer clips for front cylinder and collapse covers. Remove sparkplugs and rotate engine to place pushrods at lowest point on cam with front piston at TDC on compression stroke. Remove head, rocker assembly, and pushrods, referring to Harley-Davidson® Service Manual as necessary.

NOTE: Observe correct location of pushrods. S&S pushrod kits have longest pushrod for front exhaust, next longest for rear exhaust, shortest for rear intake, and remaining one for front intake. Remove all traces of old rocker housing gaskets from cylinder head, taking care to contain debris.

CAUTION

Debris such as gasket material can interfere with oil circulation resulting in engine damage not covered under warranty.

3. Inspect S&S rocker cover assemblies. Remove rough or sharp edges from plain (unchromed) assemblies. Clean all metal parts with solvent. Dry with compressed air and remove any solvent residue with clean, lint free cloth.
4. Beginning with the upper portion of the rocker box. Install o-ring (50-7963) into rocker shaft bore. **See Picture 2, below left.** Make sure the o-ring is completely seated in its groove. **See Picture 3, below right.**

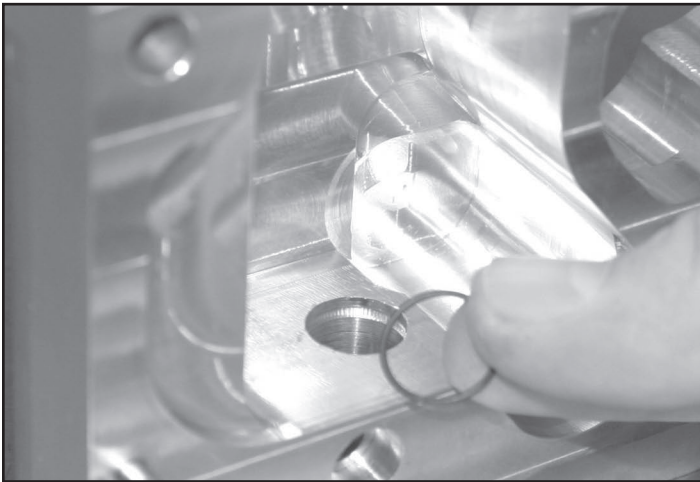

Picture 2

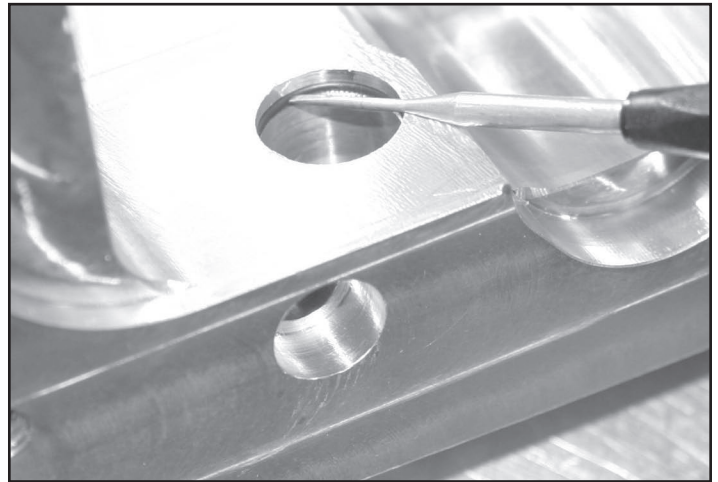

Picture 3

NOTE: Although S&S® rocker shafts for shovelheads look like late model 1984-'99 rockers, you must in use S&S rocker shafts with S&S rocker boxes. See **Picture 4, below.**

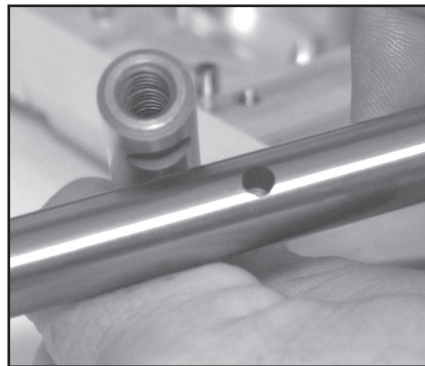

Picture 4

5. Apply a small amount of oil/assembly lube to the rocker shafts rocker arm bushings and o-ring prior to installing rocker, and shaft into the rocker box.

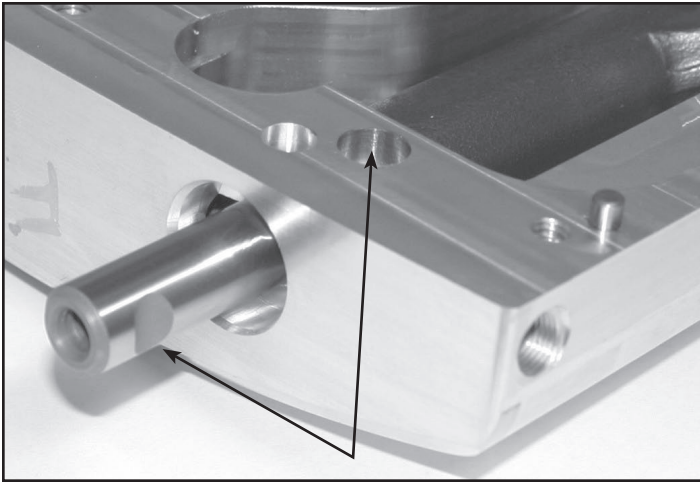

Picture 5

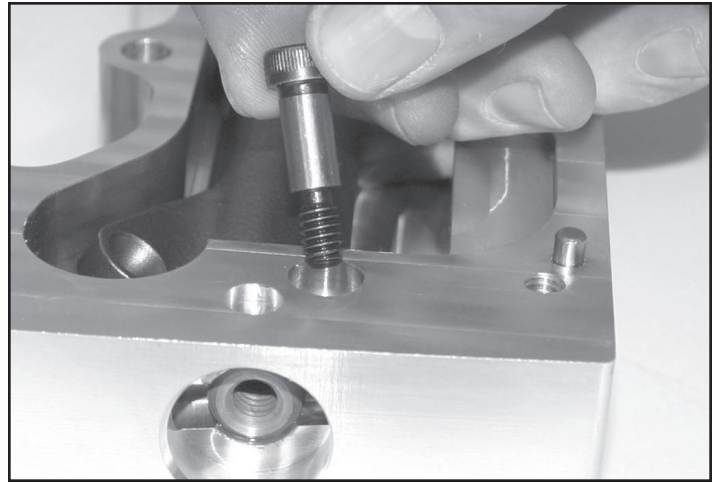

Picture 6

6. Install rocker shaft. Align notch in rocker shaft with the retaining bolt hole. **See Picture 5, above left.**
7. Install rocker shaft retaining screw (50-0318) using 242 Loctite® and torque to 90 in-lbs. **See Picture 6, above right.**
8. Install O-ring (50-7962) on rocker are shaft plug (50-8340). **See Picture 7, below.** Apply a light coating of oil to the O-ring and install plug using 242 Loctite® torque plug to no more then 90 in-lbs.

NOTE: During disassembly you must loosen rocker shaft plug before you remove the rocker shaft retaining bolt. After removing plug and retaining bolt use plug to remove rocker shaft.

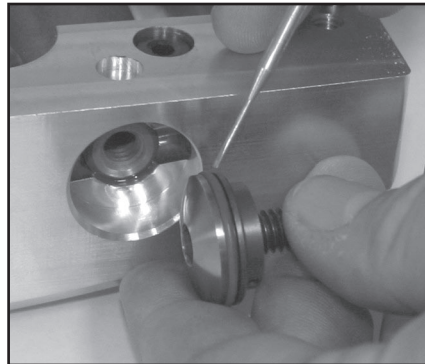

Picture 7

9. Place O-rings (50-7961) into the grooves in the lower rocker box. Use care not to pinch the O-rings. **See Picture 8, below.**



Picture 8

10. Install sealing O-rings (50-7965 front & 50-7966 rear) in their appropriate rocker box bases. **See Pictures 9, below left, and 10, below right.**

CAUTION

Sealing O-rings must be installed in the correct rocker box or an oil leak will occur. (Picture 10)

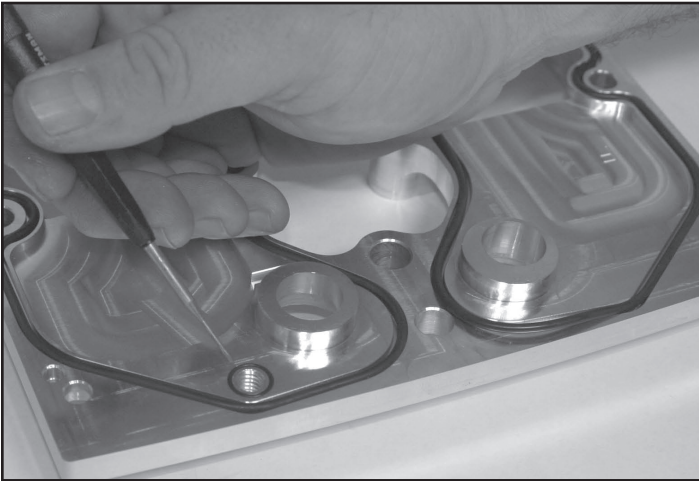

Picture 9

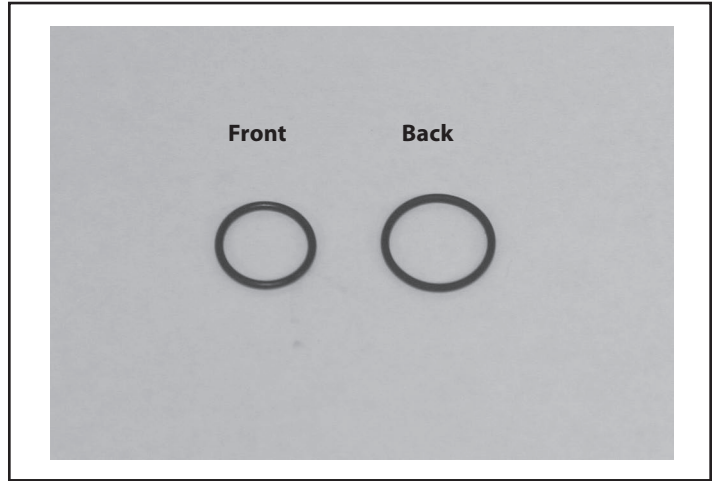

Picture 10

11. Carefully align and install upper rocker box on top of lower box. Use caution not to pinch the O-rings. **See Picture 11, below left.**

12. Carefully pick up assembly and install the two lower rocker cover bolts, (50-0294). **(See Picture 12, below right)** using 242 Loctite® Torque bolts to 90-120 in-lbs.

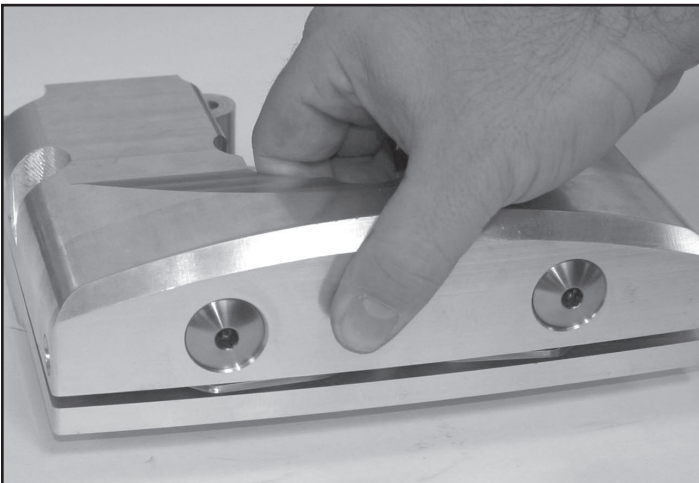

Picture 11

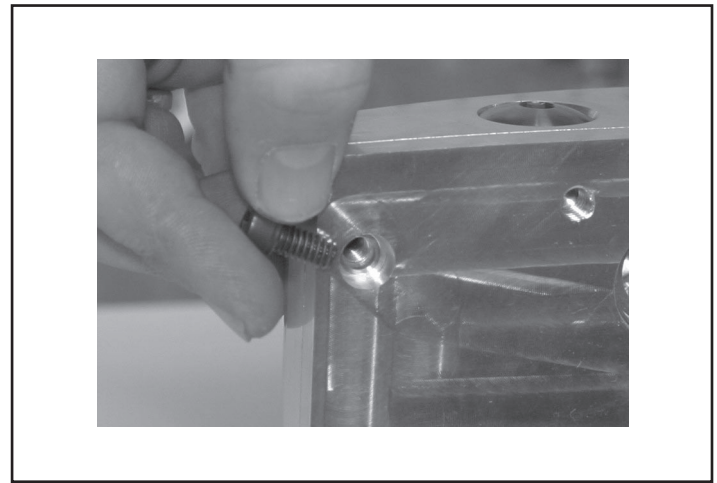

Picture 12

13. Install rocker box on to head. Care should be used to make sure the rocker arms do not get pinched between the valve spring collar and the rocker box assembly.

NOTES:

- *It is always recommended to verify proper valve stem protrusion when using S&S® rocker boxes in conjunction with any non-S&S components. A valve stem protrusion of 1.650" is recommended when using S&S rocker boxes; this will allow the use of any camshaft with a maximum lift of .590".*
- *S&S shovelhead rocker arms use a 1.5:1 ratio, and are compatible with both external oil lines as well as internal oiling. (Only when used with S&S shovelhead tappets and tappet blocks PN 33-5451.)*
- *S&S rocker boxes will accept most stock and aftermarket shovelhead rocker arms.*

CAUTION

If you will be using S&S tappets and tappet blocks (33-5451) you must install the included 1/8" Pipe plugs in S&S rocker boxes in place of your external oil lines.

NOTE: When using S&S tappet blocks (33-5451) in conjunction with an 1984-1999 cam you must recalculate the max valve lift for the shovelhead rocker ratio using the following formula.

$$\frac{\text{1984-1999 cam valve lift}}{1.625 \text{ (rocker ratio)}} = \text{Cam lobe lift}$$
$$\text{Cam lobe lift} \times 1.5 \text{ (S\&S rocker ratio for shovelhead)} = \text{Corrected lift for shovelhead engines}$$

14. Install hollow flanged bolt onto the two shortest studs in your heads. **See Picture 13, below left.** Torque flange bolts to 18 ft-lbs.

NOTE: If you are using stock Harley-Davidson® heads manufactured prior to 1979 you will need to remove 1 long stud per head (**See Figure 1, below right**) and replace it with Harley-Davidson® PN 17508-66. A propane torch is recommended for heating the head prior to attempting stud removal.

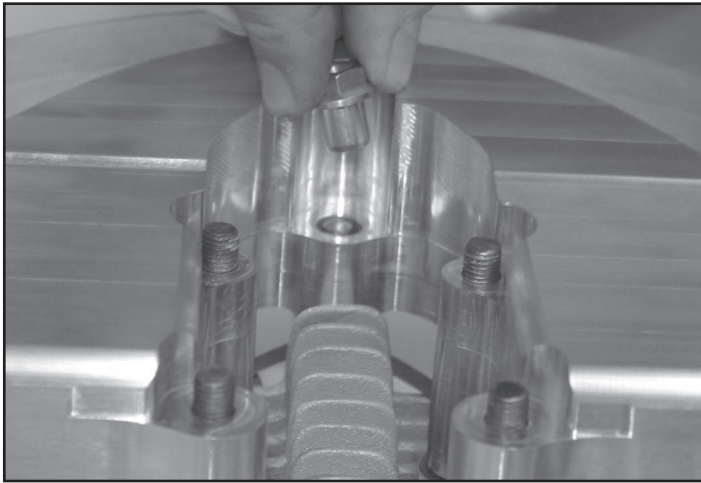

Picture 13

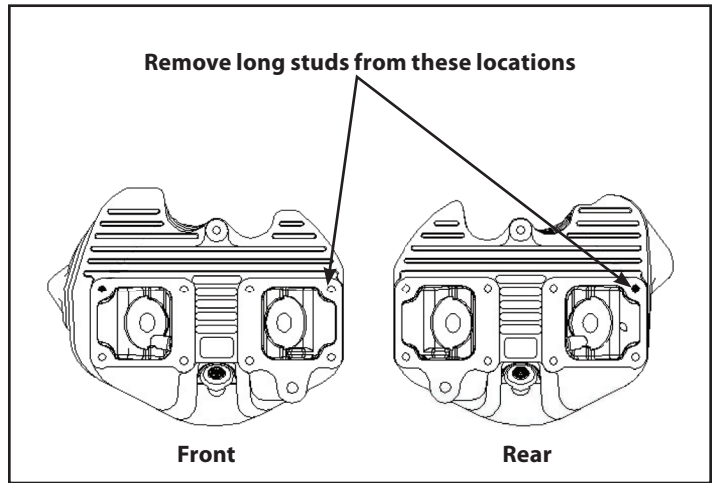
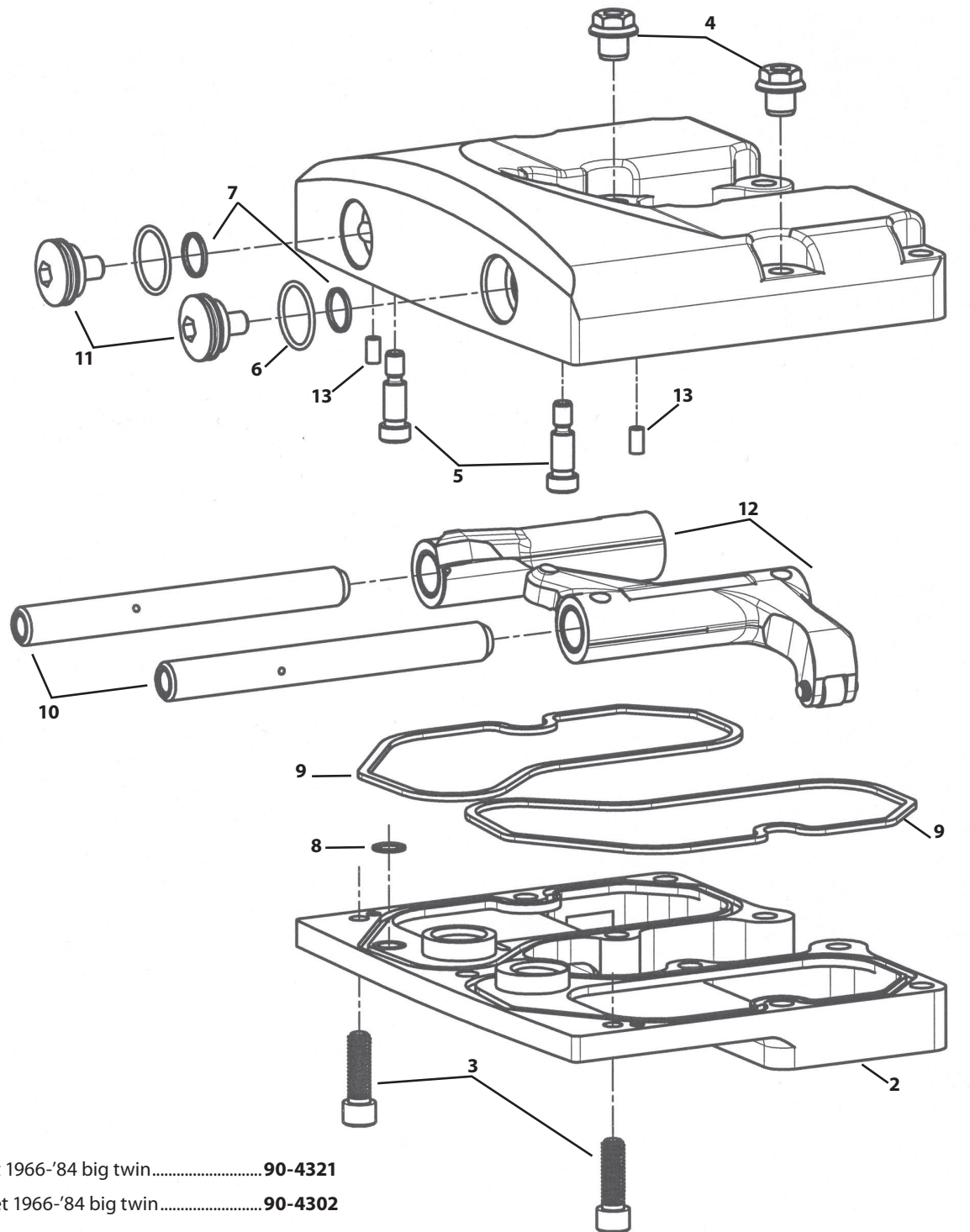

Figure 1

All reference to Harley-Davidson® part numbers is for identification purposes only. We in no way are implying that any of S&S® Cycle's products are original equipment parts or that they are equivalent to the corresponding Harley-Davidson® part number shown.



- | | | |
|--|-----------------|--|
| 1. Rocker Cover, Top, Billet 1966-'84 big twin..... | 90-4321 | |
| 2. Rocker Cover, Base, Billet 1966-'84 big twin..... | 90-4302 | |
| 3. Screw, SHS (10 Pack) | 50-0294 | |
| 4. Bolt, Internal Thread (10 Pack) | 50-8187 | |
| 5. Screw, SHS (10 Pack)..... | 50-0318 | |
| 6. O-ring, Viton® -019 (10 Pack)..... | 50-7962 | |
| 7. O-ring, Viton® 1.00mm CS x 14.00mm (10 pack)..... | 50-7963 | |
| 8. O-ring, Front, Viton® 1.00mm CS x 9.50mm ID
(10 Pack)..... | 50-7965 | |
| O-ring, Rear, Viton® 1.00mm CS x 11.00mm ID
(10 Pack)..... | 50-7966 | |
| 9. O-ring, Viton® -160 (10 Pack)..... | 50-7961 | |
| 10. Rocker Shaft Set, 1966-'84 big twin
Set | 90-4351 | |
| Individual..... | 90-4350 | |
| 11. Plug, Rocker Arm Shaft | 50-8340 | |
| 12. Rocker Arm FI/RE 1966-'84 big twin
Set | 90-4320 | |
| Front | 90-4320F | |
| Rear | 90-4320R | |
| 13. Plug, SH pipe- 1/8"-27 | 50-1030 | |

All reference to Harley-Davidson® part numbers is for identification purposes only. We in no way are implying that any of S&S® Cycle's products are original equipment parts or that they are equivalent to the corresponding Harley-Davidson® part number shown.

