

**Instruction 51-1054
12-10-14**

Copyright © 2002, 2006, 2010,
2013, 2014

by S&S® Cycle, Inc.

All rights reserved.
Printed in the U.S.A.

S&S® Cycle, Inc.

**14025 Cty Hwy G PO Box 215
Viola, Wisconsin 54664**

Phone: 608-627-1497 • Fax: 608-627-1488
Technical Service Phone: 608-627-TECH (8324)
Technical Service Email: sstech@sscycle.com
Website: www.sscycle.com



Installation Instructions: S&S® Die-Cast Rocker Covers for 1984-'99 and 1999-'15 Harley-Davidson® Big Twin Engines and S&S V-Series and T-Series engines

DISCLAIMER:

S&S parts are designed for high performance, closed course, racing applications and are intended for the very experienced rider only. The installation of S&S parts may void or adversely affect your factory warranty. In addition such installation and use may violate certain federal, state, and local laws, rules and ordinances as well as other laws when used on motor vehicles used on public highways, especially in states where pollution laws may apply. Always check federal, state, and local laws before modifying your motorcycle. It is the sole and exclusive responsibility of the user to determine the suitability of the product for his or her use, and the user shall assume all legal, personal injury risk and liability and all other obligations, duties, and risks associated therewith.

The words Harley®, Harley-Davidson®, H-D®, Sportster®, Evolution®, and all H-D part numbers and model designations are used in reference only. S&S Cycle is not associated with Harley-Davidson, Inc.

SAFE INSTALLATION AND OPERATION RULES:

Before installing your new S&S part it is your responsibility to read and follow the installation and maintenance procedures in these instructions and follow the basic rules below for your personal safety.

- Gasoline is extremely flammable and explosive under certain conditions and toxic when breathed. Do not smoke. Perform installation in a well ventilated area away from open flames or sparks.
- If motorcycle has been running, wait until engine and exhaust pipes have cooled down to avoid getting burned before performing any installation steps.
- Before performing any installation steps disconnect battery to eliminate potential sparks and inadvertent engagement of starter while working on electrical components.
- Read instructions thoroughly and carefully so all procedures are completely understood before performing any installation steps. Contact S&S with any questions you may have if any steps are unclear or any abnormalities occur during installation or operation of motorcycle with a S&S part on it.
- Consult an appropriate service manual for your motorcycle for correct disassembly and reassembly procedures for any parts that need to be removed to facilitate installation.
- Use good judgment when performing installation and operating motorcycle. Good judgment begins with a clear head. Don't let alcohol, drugs or fatigue impair your judgment. Start installation when you are fresh.
- Be sure all federal, state and local laws are obeyed with the installation.
- For optimum performance and safety and to minimize potential damage to carb or other components, use all mounting hardware that is provided and follow all installation instructions.
- Motorcycle exhaust fumes are toxic and poisonous and must not be breathed. Run motorcycle in a well ventilated area where fumes can dissipate.

IMPORTANT NOTICE:

Statements in this instruction sheet preceded by the following words are of special significance.



WARNING

Means there is the possibility of injury to yourself or others.



CAUTION

Means there is the possibility of damage to the part or motorcycle.

NOTE

Other information of particular importance has been placed in italic type.

S&S recommends you take special notice of these items.

WARRANTY:

All S&S parts are guaranteed to the original purchaser to be free of manufacturing defects in materials and workmanship for a period of twelve (12) months from the date of purchase. Merchandise that fails to conform to these conditions will be repaired or replaced at S&S's option if the parts are returned to us by the purchaser within the 12 month warranty period or within 10 days thereafter.

In the event warranty service is required, the original purchaser must call or write S&S immediately with the problem. Some problems can be rectified by a telephone call and need no further course of action.

A part that is suspect of being defective must not be replaced by a Dealer without prior authorization from S&S. If it is deemed necessary for S&S to make an evaluation to determine whether the part was defective, a return authorization number must be obtained from S&S. The parts must be packaged properly so as to not cause further damage and be returned prepaid to S&S with a copy of the original invoice of purchase and a detailed letter outlining the nature of the problem, how the part was used and the circumstances at the time of failure. If after an evaluation has been made by S&S and the part was found to be defective, repair, replacement or refund will be granted.

ADDITIONAL WARRANTY PROVISIONS:

- (1) S&S shall have no obligation in the event an S&S part is modified by any other person or organization.
- (2) S&S shall have no obligation if an S&S part becomes defective in whole or in part as a result of improper installation, improper maintenance, improper use, abnormal operation, or any other misuse or mistreatment of the S&S part.
- (3) S&S shall not be liable for any consequential or incidental damages resulting from the failure of an S&S part, the breach of any warranties, the failure to deliver, delay in delivery, delivery in non-conforming condition, or for any other breach of contract or duty between S&S and a customer.
- (4) S&S parts are designed exclusively for use in Harley-Davidson® and other American v-twin motorcycles. S&S shall have no warranty or liability obligation if an S&S part is used in any other application.

Introduction

S&S® die-cast rocker cover kits for Harley-Davidson® Evolution® engines (1984-'99) and Twin Cam 88°, 96™ and 103™ engines (1999-later) are similar, but not identical. Mounting holes are larger in the bases for 1999-later engines and in slightly different locations. Because of the different vent systems and mounting-bolt patterns, different rocker housing bases and rocker housing base gaskets are required for the two engines.

All S&S V-Series engines for 1984-'99 models, except 4 1/8" bore engines, require 1984-'99 style rocker cover kit. S&S 4 1/8" bore V-Series engines require 1999-later style rocker covers. Make sure you have the correct rocker cover kit, and follow the appropriate installation procedure.

S&S rocker covers accept valve springs up to 1.660" O.D, and will generally accept valve lifts to .710" without modification. It remains the installer's responsibility to confirm all clearances.

NOTES

- Threads should be cleaned with Loctite® primer or an equivalent before applying Loctite®. S&S has used lacquer thinner with excellent results.
- The installer must check clearances between the valve spring/top collar and rocker cover housing as well as between the rocker arm and top cover.

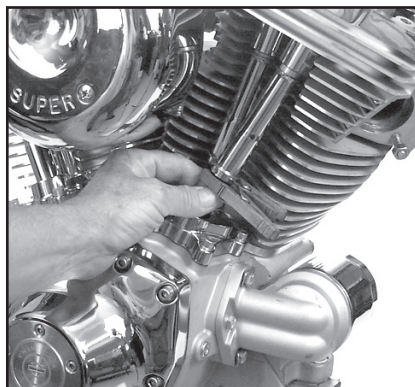

Picture 1

High-pressure air is potentially hazardous. Wear eye protection during use and direct air stream away from face and others nearby.

2. Remove original top rocker cover. Remove pushrod cover retainers from front cylinder pushrods and collapse pushrod covers.
3. Lift the rear wheel of the motorcycle with a jack, remove spark plugs, shift transmission into high gear, and turn wheel to rotate engine so that intake and exhaust pushrods/lifters for front cylinder at their lowest point of travel. Front piston will be at TDC on compression stroke with pushrods/lifters at lowest point. Confirm that both pushrods can be rotated with light finger pressure. **See Picture 1.**

CAUTION
Failure to confirm correct pushrod position can result in damage to rocker arm support plates and other parts.

4. Remove existing components according to procedures in the service manual for the model you are working on. Take care to keep parts in same order as removed, remove rocker shafts and arms from support (1999-up engines) or lower rocker housing (1984-'99 engines). Mark components according to location: "front intake," etc., so they can be returned to their original locations.
5. Remove any remaining gasket material from cylinder head gasket surface, and clean with lacquer thinner.

CAUTION
Lacquer thinner is extremely flammable, potentially explosive, and the fumes toxic when inhaled. Read manufacturer's cautions on container and use only in a well-ventilated area away from sparks and open flame.

Installation

1. Prepare for rocker cover installation by washing motorcycle, taking special care to remove dirt from engine and surrounding area. Disconnect battery, ground cable. Remove gas tanks and clean engine and surrounding area with compressed air.

CAUTION
Dirt and other contaminants can cause extensive damage if allowed to fall into engine.

WARNING
Sparks from motorcycle electrical system can ignite gasoline fumes, resulting in an explosion. Removing battery eliminates the possibilities of explosion and injury arising from inadvertent activation of the electric starter.

6. Place dowels in the holes in the rocker box surface of the cylinder head. Place the gasket on the head over the dowels as shown in **Pictures 2 and 3.**
7. Place lower rocker housing on cylinder head, aligned by dowel pins in head.

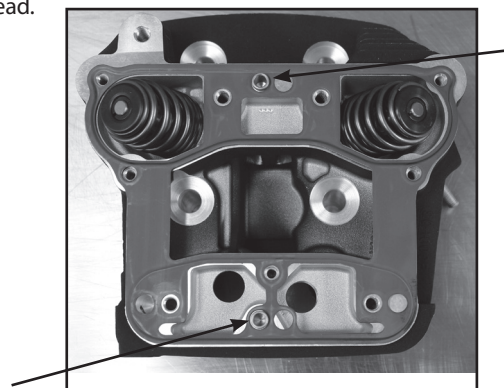

Picture 2
1984-'99 Engines

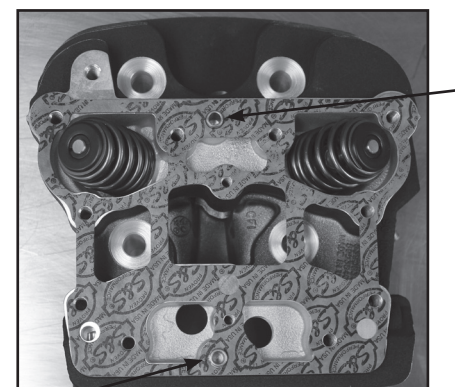

Picture 3
1999-later Harley-Davidson® Big Twins and S&S 4 1/8" Bore V-Series Engines

8. Measure clearance between rocker housing and valve spring. See **Picture 4.** Minimum is .025". If clearance is sufficient, call the S&S tech department for assistance.
9. Place new o-ring in center of rocker housing.
10. Inspect rocker shafts for burrs and excessive wear; deburr or replace as necessary. Lubricate rocker shafts with assembly lube, place rocker arms in support, and slide shafts through supports and rocker arms. Notches in shafts must face away from center of engine and align with right (camside) bolt holes. **See Picture 5.**
11. Check rocker arm endplay by sliding rocker arm as far to one side as possible and measuring gap between rocker arm and support on opposite end. Acceptable endplay is .001" to .012". If endplay is insufficient, carefully remove material from end of rocker arm to achieve correct endplay. Smooth out the area where material was removed. Clean the rocker arm thoroughly to remove any residual abrasive or metal particles before installing in engine.
12. Prepare rocker support bolts according to instructions on Loctite® container and apply thin film of Loctite® to threads.
13. Place rocker arm support assembly with rockers in rocker housing. Align pushrod ends with sockets in rockers. Install and tighten four support screws to 15-18 ft-lbs. according to sequence shown in **Figures 1 or 2.** Refer to line drawing on page 3 for correct placement of screws.

14. Install the remaining rocker box screws and tighten according to specifications in **Figures 1 or 2.** Note that screw diameter and torque requirements are different for 1984-99 and 1999-later engines.

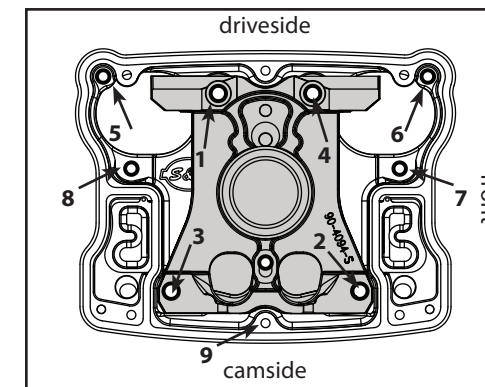

Figure 1

Tightening Sequence and Torque Specifications For 1984-99 Engines

Screw Position	Diameter	Torque Specification
1-4	5/16"	18 ft-lb
5-8	1/4"	120 in-lb
9	1/4"	100 in-lb

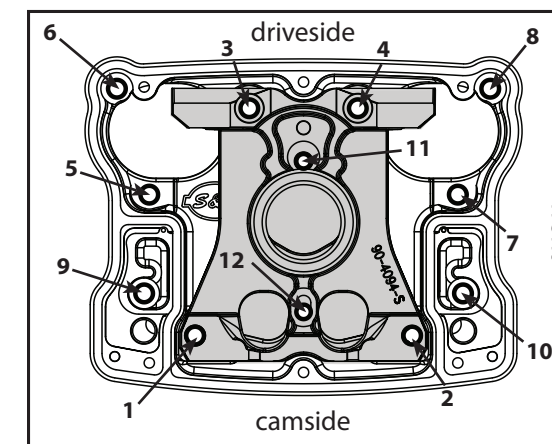

Figure 2

Tightening Sequence and Torque Specifications For 1999-Later Engines

Screw Position	Diameter	Torque Specification
1-10	5/16"	18 ft-lb
11-12	1/4"	100 in-lb

- 15.15 Wait 5-10 minutes and check pushrods. They should spin freely with light finger pressure. Do not turn the engine over before this has been confirmed.
16. Install one flat and one silicone coated washer on each of six 1/4-20 x 3/4 rocker cover screws.

NOTE: Install flat washer on screw first. silicone coated washer goes between flat washer and rocker cover.

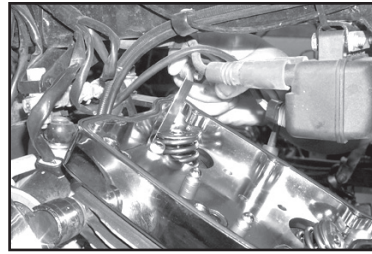

Picture 4

17. Install rocker cover and tighten screws to 90-100 in-lbs. in sequence shown. See Figure 3.

18. Extend pushrod covers and replace retainer clips.

19. Remove retainers and collapse covers of rear cylinder pushrods. Rotate engine to place pushrods at lowest point on cam with rear piston at TDC on compression stroke. Repeat rocker cover removal and installation procedure for rear cylinder.

20. Replace any parts removed for rocker cover installation, start motorcycle and inspect for leaks.

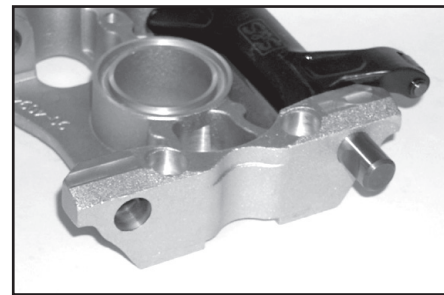

Picture 5

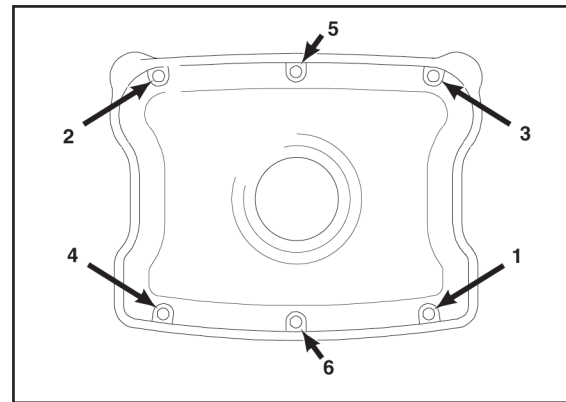
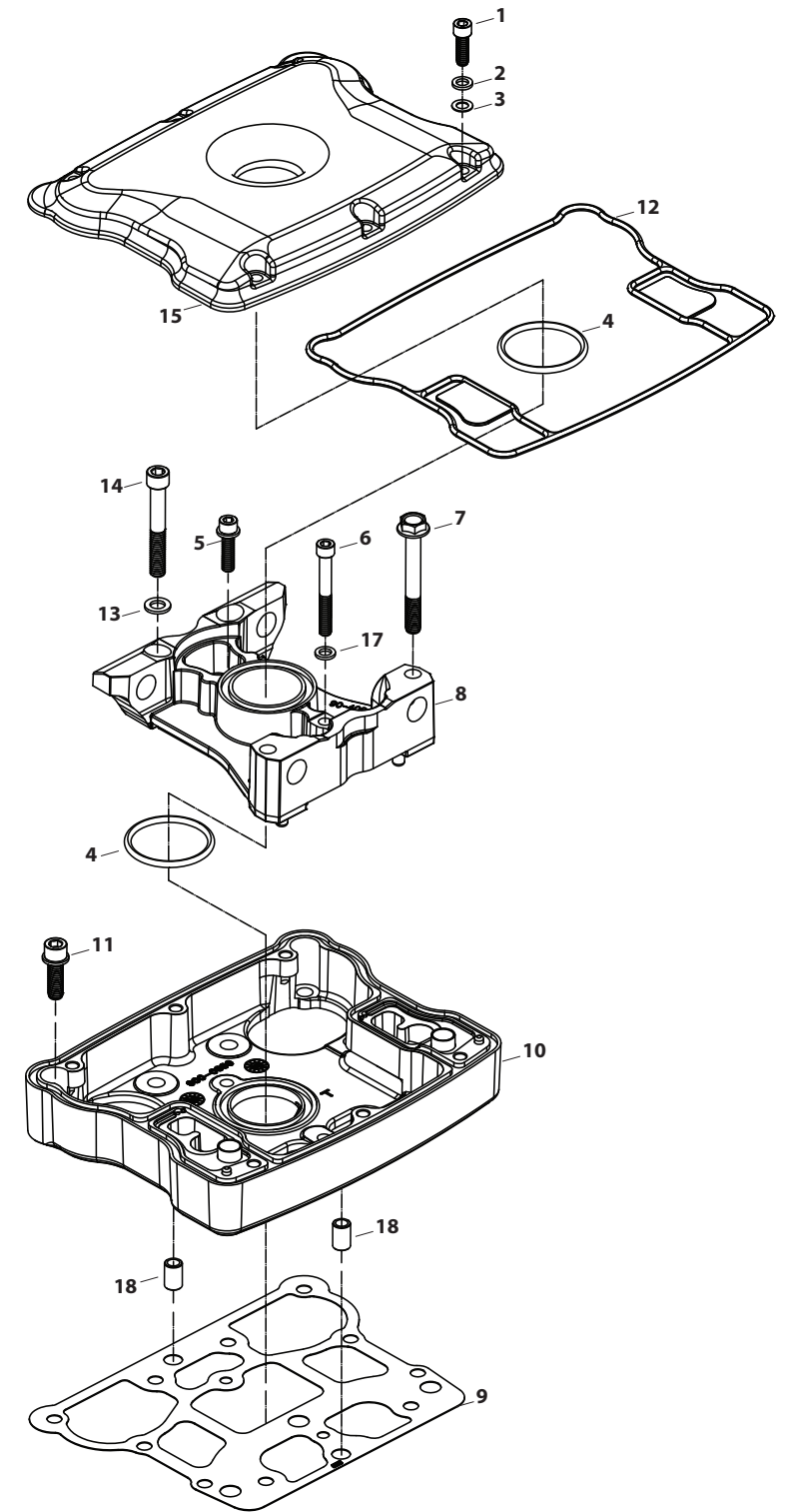

Figure 3

REPLACEMENT PARTS FOR S&S® DIE-CAST ROCKER COVERS FOR 1999-UP HARLEY-DAVIDSON® BIG TWIN ENGINES, S&S T-SERIES, AND S&S 41/8" BORE V-SERIES ENGINES

- | | |
|--|-------------------------------|
| 1. Screw, socket head 1/4"-20 x 3/4" (H-D*4069A) (each)..... | 50-0067 |
| | 50-0144 |
| 2. Washer, flat 1/4" (each) | 50-7017 |
| 12 pack | 50-7013 |
| 3. Washer, silicone coated 1/4" (each) | 50-7015 |
| 8 pack..... | 50-7015-8 |
| 12 pack | 50-7015-12 |
| 4. Seal, o-ring
(Included in gasket kit see #16 below.) | |
| 5. Screw, socket head, 1/4"-20 x 1" | 50-0092-S |
| each | 50-0092P |
| 4 pack..... | 50-0154 |
| 10 pack | 50-0154 |
| 6. Screw, socket head, 1/4"-20 x 2" (H-D*25794-36)..... | 50-0013 |
| 7. Screw, hex flange head, 3/16"-18 x 2 1/2" (H-D*3501) | 50-0123 |
| 8. Support, rocker arm..... | 90-4140 |
| 9. Gasket, rocker cover, Graphite
For S&S rocker covers on S&S or stock heads | |
| each | 90-4071-S |
| 2 pack..... | 90-4071 |
| 10 pack..... | 90-4099 |
| 10. Housing, rocker, Chrome | 3,7,13 90-4107 |
| 11. Screw, socket head, 3/16"-18 x 1" | 50-0125-S |
| 12. Seal, rocker cover
(Included in gasket kit see #16 below.) | |
| 13. Washer, flat 3/16" (each) | 50-7056 |
| 10 pack | 50-7082 |
| 14. Screw, socket head 3/16"-18 x 2 1/4" (H-D*853A) | |
| each | 50-0115-S |
| 10 pack | 50-0156 |
| 15. Cover, rocker, chrome..... | 1,2,3,7,8,10,11,12,13 90-4089 |
| 16. Gasket set - rocker cover, cast (Not Shown)..... | 90-4111 |
| 17. Washer, .261" x .474" x .050", Annealed, Stainless Steel | |
| each | 50-7020 |
| 12 pack | 50-7076 |
| 18. Pin, Dowel, Hollow, .374" x .575", Steel | NA |



REPLACEMENT PARTS FOR S&S® DIE-CAST ROCKER COVERS FOR 1984-'99 HARLEY-DAVIDSON® BIG TWIN ENGINES AND S&S V-SERIES ENGINES (EXCEPT 41/8" BORE)

1. Screw, socket head 1/4"-20 x 3/4" (H-D®4069A) (each) **50-0067**
12 pack **50-0144**
2. Washer, flat 1/4" (each) **50-7017**
12 pack **50-7013**
3. Washer, rubber coated 1/4" (each) **50-7015**
8 pack **50-7015-8**
12 pack **50-7015-12**
4. Seal, o-ring (Included in gasket set see #16 below.) **50-8044**
5. Screw, SH 1/4"-20 x 2" (H-D®25794-36) **50-0013**
6. Screw, hex flange head 5/16"-18 x 2 1/4" (H-D®3501) **50-0123**
7. Support, rocker arm **90-4140**
8. Bottom gasket, rocker housing, 1984-'99 bt (except S&S 4 1/8" bore V-Series)
each **900-0538**
2 pack **900-0592**
9. Housing, rocker, chrome (except S&S 4 1/8" bore V-Series)
1984-'99 bt **900-0790**
10. Screw, SHCS 1/4"-20 x 1" 1984-'99 bt (except S&S 4 1/8" bore V-Series),
(each) **50-0092-S**
4 pack **50-0092P**
10 pack **50-0154**
S&S 4 1/8" Bore, SHCS 5/16"-18 x 1" **50-0125-S**
11. Seal, rocker cover (Included in gasket set see #16 below.) **90-4079**
12. Washer, flat 5/16" (each) **50-7026**
10 pack **50-7028**
13. Screw, SH 5/16"-18 x 2 1/4" (H-D®853A) (each) **50-0115-S**
10 pack **50-0156**
14. Cover, rocker, chrome **900-0706**
15. Gasket Set (N/S)
1984-'99 bt **90-4091**
16. Washer, flat, .261"x.474"x.050" Annealed, Stainless Steel
each **50-7020**
10 pack **50-7076**
17. Pin, Dowel, Hollow, .374" x .575", Steel **NA**

(N/S) = Not Shown

