Contact Us:

Phone

Office (719) 633-3811
Fax (719) 633-3496
Tech Support Line (Toll Free) (866) 365-2762

Web

<http://www.snowperformance.net>

Email

sales@snowperformance.net
customerservice@snowperformance.net
tech@snowperformance.net

Mail

Snow Performance, Inc
213 Aspen Garden Way
Bldg. #1
Woodland Park, CO 80863

Notes

The contents of this document are subject to change without prior notice. No part of or this entire document may be reproduced in any form without prior written permission of Snow Performance, Inc under the copyright except for private use.

The names, addresses and telephone numbers mentioned are current as of September 20, 2007. Note that this information is subject to change. Please refer to www.snowperformance.net for current information.

Water/Methanol Injection



**Boost
Cooler™**

INSTALLATION INSTRUCTIONS FOR PART #20010 WATER / METHANOL INJECTION SYSTEMS



SNOW PERFORMANCE
COOLER, LIGHTER, FASTER™

CONTENTS

Kit Contents.....	3
Introduction.....	4
Nozzle Identification Chart:.....	4
Installation – Mechanical.....	5
Installation - Electrical.....	10
Variable Controller Installation.....	10
Variable Controller Tuning.....	11
Controller Operation Example.....	11
Testing the System.....	12
Tuning Quick Reference.....	13
Fluid Level Switch (optional).....	15
Solenoid Upgrade (optional).....	16
Install Notes.....	17



You must completely read through these instructions before installing and operating this product. Failure to do so can result in damage to this product and the vehicle.

LIFETIME WARRANTY

Snow Performance's commitment to providing the best water/methanol system is reflected in the Lifetime Warranty that is standard on all Snow Performance Boost Coolers™. We are able to offer this warranty due to our control of manufacturing quality and the historically high reliability of our products in the field.

Warranty Policy

Snow Performance, Inc. (hereafter "Snow") warrants that the Product shall conform to and perform in accordance with published technical specifications and shall be free of defects in materials and workmanship as long as :

The exclusive fluid used in the kit has been Snow performance's Boost Juice™ water methanol product as evidenced by sales receipts confirming purchases.

In the event that Boost Juice has not exclusively been used, A One Year Warranty applies.

In the event of failure, Snow will repair or replace the part at Snow's sole discretion. Failures resulting from misapplication or misuse of the Product, failure to adhere to any specifications or instructions, or failure resulting from neglect, abuse, accidents, or acts of nature are not covered under this warranty.

Warranty service may be obtained by delivering the part to Snow and providing proof of purchase. Customer agrees to insure the Product or assume the risk of loss or damage in transit, to prepay shipping charges to Snow, and to use the original shipping container or equivalent. Warranty is valid only for original purchaser and is not transferable. This Warranty gives you specific legal rights, and you may also have other rights which may vary from state to state.

This warranty applies to Snow manufactured Boost Cooler™ kits.

Non-Warranty Repair/Retest

Products returned due to damage or misuse and Products retested with no problem found are subject to repair/retest charges. A purchase order or credit card number and authorization must be provided in order to obtain an RMA (Return Merchandise Authorization) number prior to returning Product.

Disclaimer

Do not use this product until you have carefully read the following agreement.

This sets forth the terms and conditions for the use of this product. The installation of this product indicates that the BUYER has read and understands this agreement and accepts its terms and conditions. Performance products by their nature are designed to increase horsepower and performance not engineered in the original vehicle and the increased stress could result in damage to related systems. This is a high performance product – use at your own risk. Snow Performance Inc., Its agents, employees or owners shall not be under any liability whether in contract or otherwise whether or not resulting from our negligence or contents of information supplied for any damage or loss resulting from such information.

The **BUYER** is responsible to fully understand the capability and limitations of his/her vehicle according to manufacturer specifications and agrees to hold the **SELLER** harmless from any damage resulting from failure to adhere to such specifications.

The **SELLER** disclaims any warranty and expressly disclaims any liability for personal injury or damages. The **BUYER** acknowledges and agrees that the disclaimer of any liability for personal injury is a material term for this agreement and the **BUYER** agrees to indemnify the **SELLER** and to hold the **SELLER** harmless from any claim related to the item of the equipment purchased. Under no circumstances will the **SELLER** be liable for any damages or expenses by reason of use or sale of any such equipment.

The **BUYER** is responsible to obey all applicable federal, state, and local laws, statutes, and ordinances when operating his/her vehicle, and the **BUYER** agrees to hold **SELLER** harmless from any violation thereof.

The **SELLER** assumes no liability regarding the improper installation or misapplication of its products.

It is the installer's responsibility to check for proper installation and if in doubt, contact the manufacturer.

Kit Contents

Parts

- 1 150+ psi Pump
- 2 qt Reservoir
- 8 ft Red High Pressure Tubing
- 4 ft Black Wire Loom
- Installation Instructions

Electrical Packet

In small bag:

- 1 Green LED
- 4 Blue Butt Connectors
- 3 Small Eyehook
- 1 Male Connector
- 3 Female Connectors
- 1 Vacuum "T"

- VC-25/MAF Controller With Harness
- 10 Tie Wraps

Mechanical Packet

In small bag:

- 1 Nozzle Holder
- 2 3/8" NPT – 1/8" NPT Reducer Bushings
- 2 1/8" NPT – 1/4" Tube Elbow Fittings
- 7 #8x1&1/2" Screws
- 7 #8 Washers
- 1 #6x1/2" Screw

- 2 Stickers
- 18 in 1/8" Tygon Tubing
- 2 Nozzles
- 1 1/8" NPT Tap
- 1 E-6000 (GOOP)

Required Tools

- Electric Drill w/ Drill Bits
- Utility Knife
- Screwdriver – Phillips
- Assorted Wrenches

Introduction

- Please refer to system diagram during install. The optional fluid level switch (#40030) is shown.

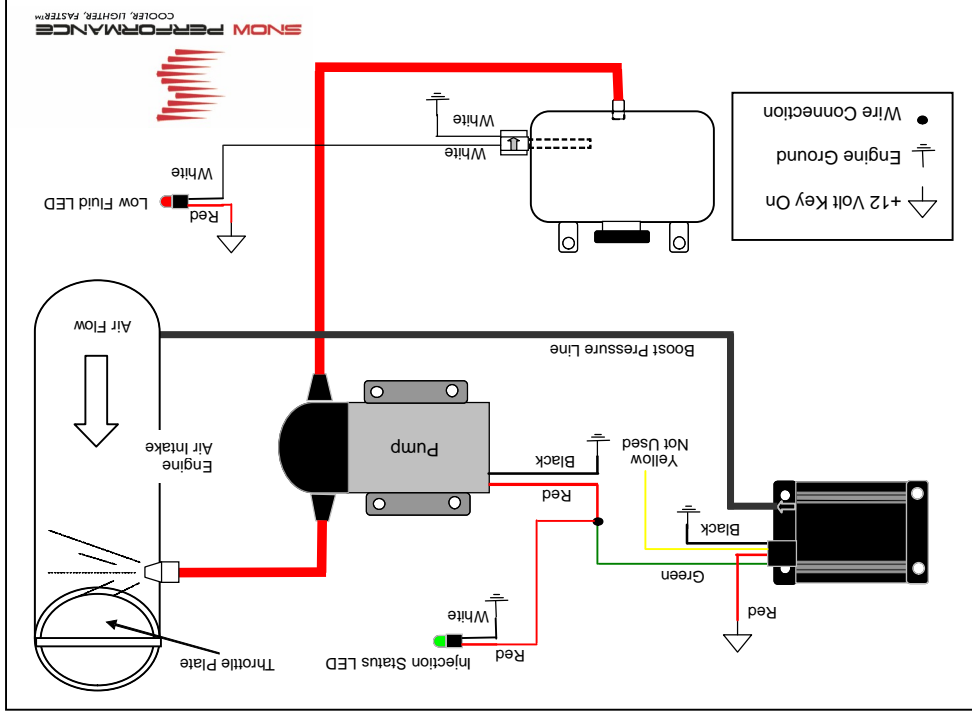

Nozzle Identification Chart:

Nozzle Color	Nozzle Size	Nozzle Color	Nozzle Size
Green	175 ml/min	Blue	625 ml/min
Black	100 ml/min	Red	375 ml/min
Yellow	60 ml/min	Purple	225 ml/min

Install Notes

Pump Setting _____ (psi)

Nozzle Size _____ (ml/min)

Boost / Vacuum setting _____

Misc: _____



Solenoid Upgrade (optional)

The optional Solenoid Upgrade (#40060) is required if the nozzle is to be installed after the intake throttle plate, or the fluid reservoir is mounted higher than the nozzle.

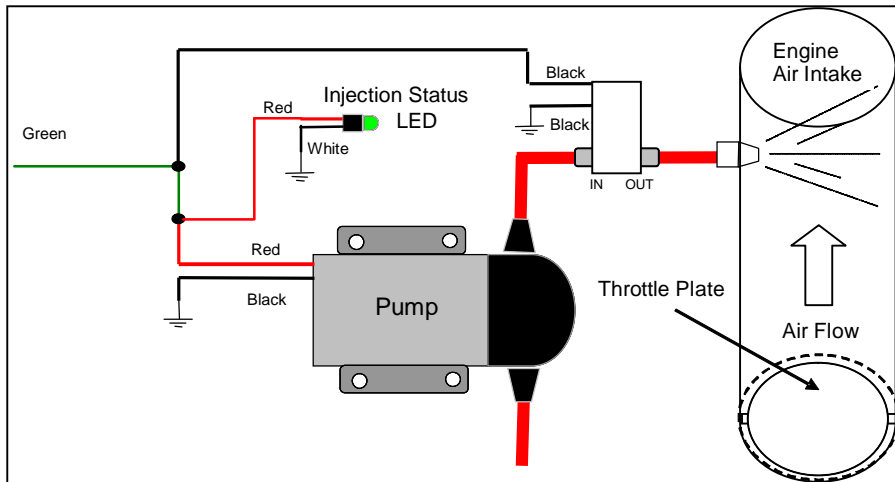

Hand thread the two 1/8" NPT quick connect fittings into ports labeled IN and OUT on the solenoid. Tighten an additional half turn.

Cut high pressure line at location solenoid is to be installed. Insert ends of cut line into quick connect fittings of solenoid. The port labeled IN is the inlet and the port labeled OUT is the outlet. Firmly pull on line to check secure connection. If line pulls out, re-insert farther into fitting to engage locking clips. If high pressure line removal is required, firmly press in plastic fitting ring to disengage locking clips while pulling hose from fitting.

Connect one of the BLACK wires from solenoid to the RED positive pump wire. Note that connecting the wire to any other power source other than the pump wire will result in improper operation of solenoid. Connect the second BLACK wire to a secure chassis ground location.

Installation – Mechanical

Step 1 Reservoir Install

Mount reservoir as high in engine compartment as possible using #8x1½" sheet metal screws and washers provided.

Optional: The factory windshield washer reservoir can be used as the reservoir for your system.



- Drill 9/16" hole in desired bulkhead location.
- Remove one nut from and turn the remaining nut until it is at the very end of the bulkhead.
- Feed red tubing through the drilled hole and up and out of the top of the reservoir.
- Attach red tubing to the bulkhead on the side opposite the nut.
- Pull the tube through the bulkhead hole until the bulkhead seats against the inside of the reservoir.
- Apply liberal amount of methanol resistant sealant around bulkhead.
- Slide the nut you had previously removed up onto the tube and thread it onto the bulkhead.
- While pulling firmly on the red tubing, tighten the outer nut using a 17mm socket (only needs to be hand tight).
- Once sealant has set, fill reservoir with water and check for leaks.

TECH TIP You can mount the tank in the rear of the vehicle. The pump is a pusher type by design so it needs to be mounted as close to the reservoir as possible. Because the pump is oversized, injection pressure will not be affected. A Solenoid Upgrade is recommended for rear mounted reservoirs.

Step 2 Pump Install

Install 3/8" to 1/8" reducer bushing using GOOP sealant on threads. Tighten 2-3 turns past hand tight. Install 1/8" elbow fitting into bushing using GOOP sealant on threads. Tighten 2-3 turns past hand tight. Mount pump so the pump inlet is positioned at the lowest point of the reservoir or lower. Pump can be mounted horizontally or vertically using (4) supplied #8x1 1/2" screws and washers.

In cramped engine bays, inside the fender or behind the front bumper is often a good alternative.

Measure the distance from the reservoir outlet to the pump inlet. Cut the 1/2" red tubing using utility knife. Make cuts are as square as possible.

Ensure there are no kinks in the tubing and insert tubing into quick

disconnects at pump and reservoir until fully seated.



Optional 7 Qt. Reservoir Shown (#40020)

NOTE: The new style pump is factory set at 150 psi. It can be turned up 1-2 full clockwise turns to increase pressure (180+ psi depending on nozzle size). The old style pump is factory set at 150 psi and it CAN NOT be turned up. DO NOT ATTEMPT TO TURN UP THE PRESSURE BEYOND THE FACTORY SETTING. The old style pump can only be turned down.

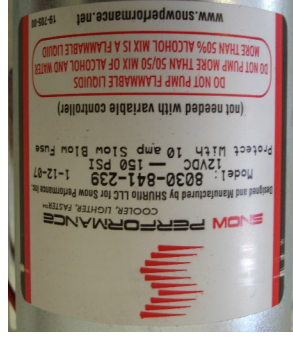

New Style

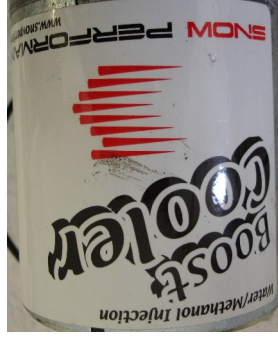

Old Style

Fluid Level Switch (optional)

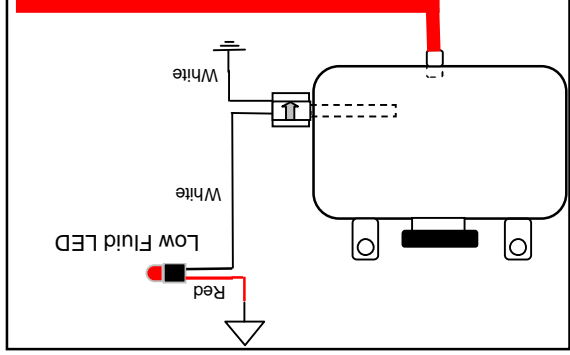

Instructions

- After mounting reservoir, mount red LED in dash next to the green "injection" LED is usually easiest.

- Wire LED per diagram with Red wire to a 12v key on source, and the White wire to one of the White wires of the level switch.

- Connect other White wire of the level switch to vehicle ground.

- With key-on source enabled, the red LED should be "on" with no fluid in the reservoir. Upon filling the reservoir, the red LED should be "off".

TECH TIP The level switch is designed to indicate when there is less than 1" of fluid in the reservoir.

If you go too far on the screw clockwise, then you can strip out the plastic threads.

Maintenance — Remove nozzle(s) and clean screen filters at least once per year using carb cleaner.

The Boost Cooler® has been designed to operate with high concentrations of methanol. Oil or other additives are not required for system lubrication.

For best performance, cooling and system life it is recommend that Snow Performance Boost Juice™, part #40008, be the exclusive fluid used in the system.

Step 3 Nozzle Selection

Nozzle sizing is a function of horsepower, which approximates the engine airflow, and boost, which approximates intake charge heat.

Recommended starting points:

250 - 350 RWHP:	175ml/min nozzle.
350 - 475 RWHP:	375ml/min nozzle
475 - 600 RWHP	625ml/min nozzle

TECH TIP Seal the nozzle into the nozzle holder using GOOP sealant. Using a sealant that is not permanent will allow for nozzle changes during tuning. Simply remove the nozzle, clean the threads, and reinstall using sealant.

Assemble desired nozzle into nozzle holder using methanol resistant sealant. **The end of the nozzle with the fine mesh screen is to be inserted into the nozzle holder.** Torque at least 1/2 turn past hand tight.



Correct



Incorrect

NOTE: If nozzle is mounted lower then the reservoir, a Solenoid Upgrade (#40060) must be used to prevent draining.

Step 4 Nozzle Mounting

The nozzle assembly should be installed 90° to the direction of airflow. On round intake tubes, this is 360° around the tube meaning the nozzle can be mounted in any direction. This will ensure maximum cooling as the nozzle sprays in a cone pattern. Choose and mark mounting location on air intake for nozzle placement.

Drill and tap (11/32" pre-drill, 1/8"-27 NPT tap) air inlet tube as close as possible to throttle body/throttle plate.



The nozzle is mounted into the intake using its external 1/8 NPT threads. Tighten the nozzle and nozzle holder assembly one half turn past hand tight using methanol resistant sealant to seal the threads.

On carbureted applications the nozzle can be mounted before or after the throttle plate. A Carb Plate is available (#40050) for 4150 style square bore carburetors.

You can mount the nozzle in a plastic or rubber air inlet tube using a Nozzle Mounting Adapter (#40110).

TECH TIP The recommended nozzle mounting point is before the throttle body/plate. If you mount the nozzle after the throttle body/plate, a Solenoid Upgrade must be used to prevent siphoning at idle (#40060).

Tuning Quick Reference

Increase base timing in 2 degree increments until the first hint of detonation then back off 2 degrees (use 3rd gear pulls from 2000 RPM).

The kit enables the use of increased timing which provides for over 50% of the potential power increase (denser intake charge the remainder). All other factors being the same, if base timing is not increased over the non-water/methanol injection settings, power increase will be less.

After tuning, ensure that reservoir has adequate fluid at all times. It is recommended that reservoir always be at least 1/4 full.

If you install the kit and do not tune the engine, you will see minimal results. The kit is for detonation control and will allow more power yielding boost and/or timing to be utilized.

The Boost Cooler® adds an alternate fuel source as well as significantly cools combustion. With the Boost Cooler®, one does not need to cool combustion with overly rich air/fuel ratios. To minimize combustion quench, you should start with an air to fuel ratio of 12.0-12.5:1 with a conservative timing setting.

Injecting water/methanol lower than 3300 - 3500 RPM could result in combustion quench. All vehicles are different. If the engine bogs or loses power, then it is coming on too early, the quantity is too much, or there is not enough methanol in the mixture (50/50 water/methanol recommended).

If you have to increase the onset too high in the rpm range (detonation control is needed sooner), decrease pump pressure and/or go to a smaller nozzle.

In the black head of the pump, there is a 2mm Allen head screw that will regulate the pressure. On the 150 psi pump, for every full turn counter clockwise you will decrease the pump pressure by 18-20 psi. On the 220 psi pump it will decrease the pump pressure 20-22psi for every turn counter clockwise.

When increasing the pump pressure, the allen screw will become tight. This is full pressure. BE CAREFUL NOT TO OVERTIGHTEN.

Testing the System

Step 1 Test Pump and Mechanical System

Disconnect pump from controller. Using a 12 volt source, apply power to red wire of pump. Pump should activate, green LED should go on, and fluid level in tank should go down. It is recommended to also check the nozzle spray pattern while following this procedure. Also check for leaks.



If pump goes on and fluid level doesn't go down, there is an obstruction in the tube or nozzle.

Activation of pump for short periods (2 - 5 sec.) will not cause engine damage.

Step 2 Test Controller

- Begin the testing process with both dials on the variable controller at their lowest settings (counter-clockwise).
- Turn ignition key on so that the system has 12 volt power. If the pump runs, inspect ground wires for secure connection.
- Pump should be off at this point, apply light air pressure into vacuum tube connection on back of controller. Pump should activate while low pressure is applied but not enough to completely atomize fluid.

Step 5 Nozzle Connection

Measure the distance from the pump outlet to the nozzle holder.

Cut the 1/4" red tubing using utility knife. Make cuts are as square as possible.

Ensure there are no kinks in the tubing and insert tubing into quick disconnects until fully seated.

Gently pull on tubing to ensure a good connection.

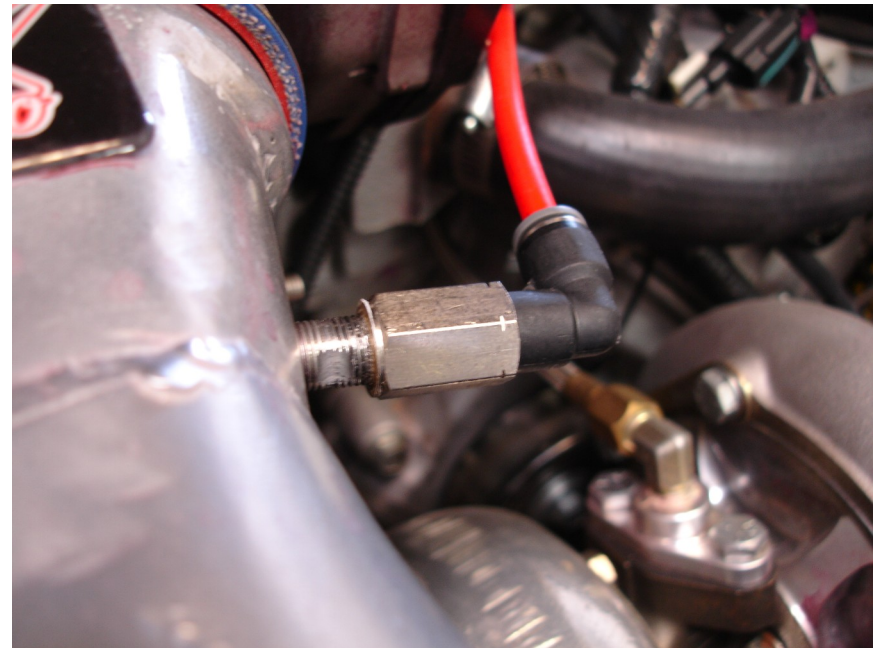

Use tie wraps to help route tubing and to ensure it doesn't contact moving or hot parts in the engine compartment.

Installation - Electrical

Variable Controller Installation



The figure above shows the back view of the variable controller. Attach controller to secure location with easy access in engine bay or passenger compartment. The VC series controllers are designed to withstand engine bay conditions, but should not be mounted directly to the engine block. Connect vacuum/boost hose from intake plenum to hose barb on back of controller and secure with a tie wrap. Plug wire harness into back of controller. Note the terminal positions are numbered on the bottom side of wire harness connector. Your controller has an internal self resetting fuse such that an external automotive type fuse is not required. In the case of a fault the internal fuse will attempt to reset after about 1 minute.

CAUTION: Disconnect the negative battery terminal while connecting wires to prevent electrical fire or damage to controller.

- Connect GREEN wire at position 4 to Pump RED power wire.
- Connect RED wire at position 3 to +12V key on source. When selecting a 12V key on source, try to find a dedicated circuit with at least a 15 AMP fuse (25 AMP with 220psi pump).
- Connect BLACK wire at position 1 to a good ground location.
- The YELLOW wire at position 2 is not used in boost referenced applications.

TECH TIP Always insure to have a good electrical ground connection. A poor ground will result in erratic operation of controller.



Variable Controller Tuning

- Rotate the MODE switch clockwise to select BOOST mode.
- Adjust the START boost level first by turning dial clockwise to about one third of the engines max boost output. This sets the boost pressure required to activate the injection system.
- Next, adjust FULL to the engines max boost output.
- Note - overlapping the settings, where the FULL dial is lower than START, will result in max injection at the onset point.
- Adjust FULL dial until a smooth power curve is felt with no mistfiring.

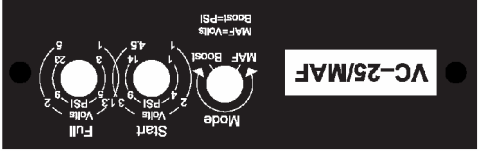

Controller Operation Example

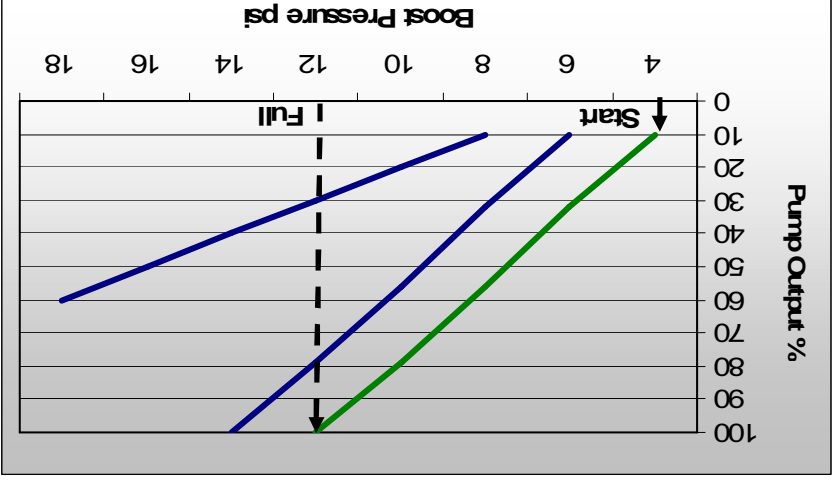

For setting 1, green, the chart shows the Start dial at 4psi and the Full dial at 12psi. At 4psi of boost pressure the pump will operate at 10%. At 12psi of boost pressure, the pump will deliver 100% of injection pressure. For boost pressure readings between the Start and Full settings, the controller will linearly adjust the pump pressure as shown on the graph.

