

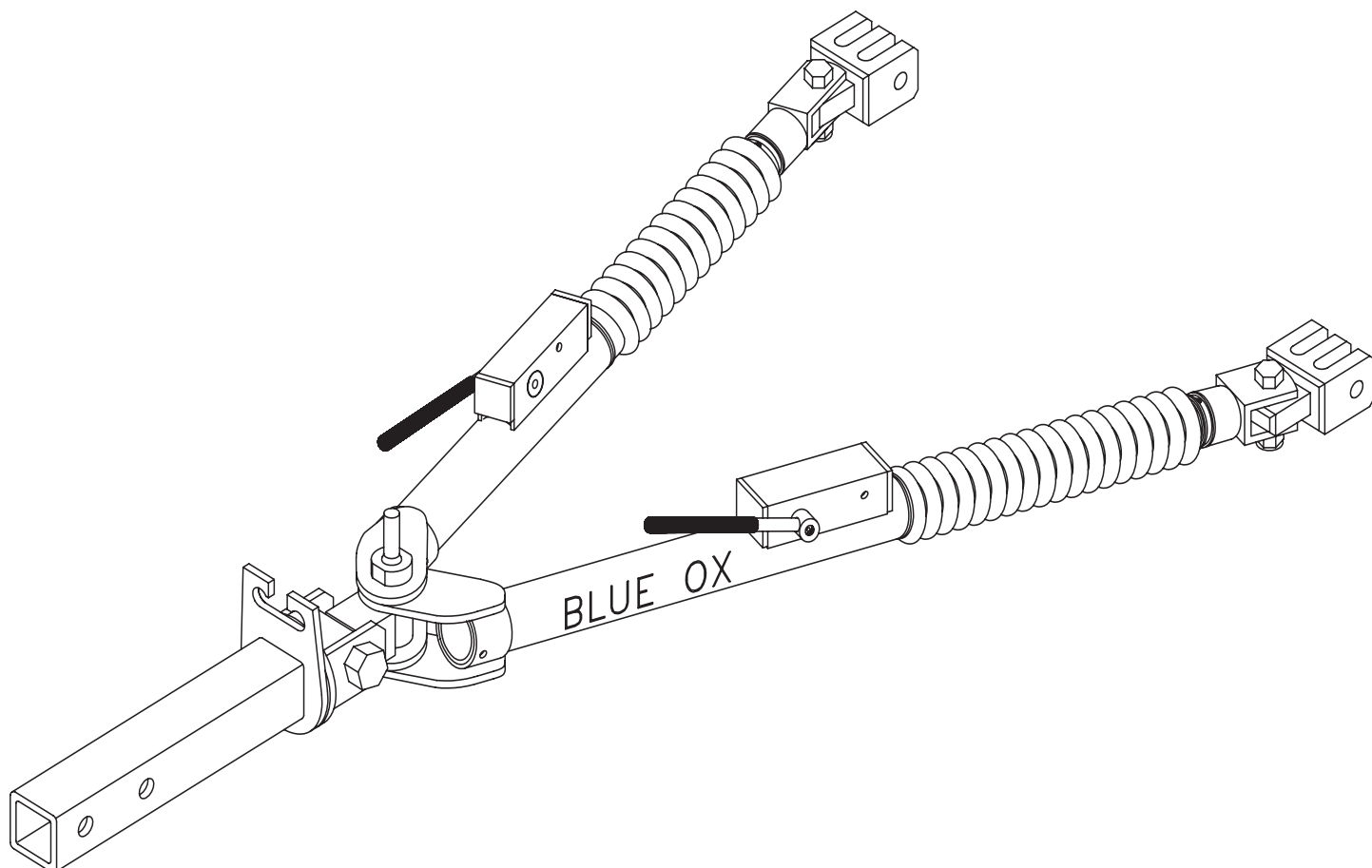

ALADDIN[®]



OPERATOR, PARTS, AND INSTALLATION MANUAL

BX4325 ALADDIN[®] Tow Bar (7500 lb) 2 Inch Receiver



SAFETY

DO NOT INSTALL, OPERATE OR USE THIS EQUIPMENT UNTIL THE FOLLOWING OPERATING AND SAFETY INSTRUCTIONS HAVE BEEN READ AND UNDERSTOOD.



This symbol is used to bring attention to safety precautions and instructions. When you see this symbol, be alert and pay attention to all instructions. **YOUR PERSONAL SAFETY IS INVOLVED.**

1. Blue Ox Tow Bars should be used with cars designed or modified to be towed.
2. Set the transmission for towing according to the owners manual. **Verify recreational towing procedures in the vehicle owners manual.**
3. Unlock the steering wheel for towing to allow the front wheels of the towed vehicle to “track”.
4. Be sure the front end of the towed vehicle is properly aligned. Unaligned vehicles will cause poor tracking and abnormal wear on the tires.
5. **The use of safety cables or chains is required by law in some states of the United States and territories of Canada. Check with the states or territories that you plan to travel through prior to your trip. Blue Ox strongly recommends the use of safety cables (BX88196 or BX88197) and our permanent baseplate safety cables (BX88207 or BX88208) with all applications of towing. Please refer to their specific installation instructions for more information.**
6. Check clearance between vehicles in a turning situation.
7. Rear lighting is required on the towed car. A BX8811 Wiring Kit, BX8834 Light Bar, BX8847 (Saturns) or BX8869 (Bulb & Socket) is recommended.
8. Prior to a towing trip, check to be sure all the towing accessories and attachment points are secure. Check for cracked welds and loose bolts/pins on baseplate and tow bar. This is important on all occasions, but particularly on a new installation, when they should be checked just prior to initial towing and again after 100-200 miles of towing.
9. **Do Not Back Up** when towing. Damage to both vehicles and towing system may occur.
10. Avoid sharp turns and rough terrain. Check installation after any unusual event and periodically on a long trip.
11. Do not use the Towed Vehicle for storing luggage, etc.; you may exceed the towing capacity of the Tow Bar and its accessories.

SAFETY CABLE INSTALLATION

1. Using the cable hooks, attach the cables to a solid part of the chassis of the towed vehicle or to the convenience links. Slip the end of the hook through the neoprene keeper to prevent the hook from unhooking. (See Fig. 3) **NOTE:** It is best to have permanent chains that connect the convenience links to the frame of the car. (See Fig. 2)

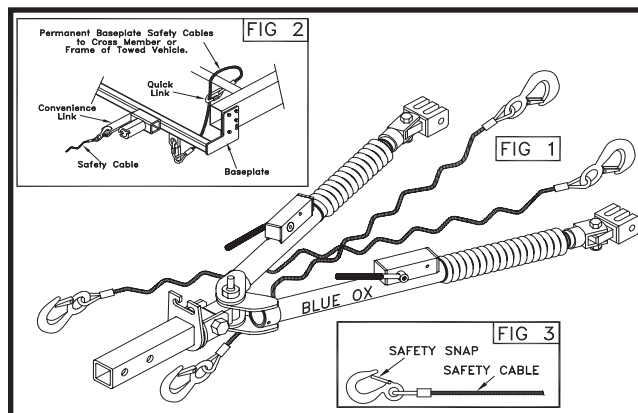

2. **NOTE: Do not wrap safety cables around legs or damage could occur to the rubber boots. If it is necessary to remove slack from the cables, wrap each once around their respective tow bar legs in front of the latch housing and then cross them under the tow bar.** (See Fig. 1)
3. Using the cable hooks, attach the opposite ends of the cables to a solid part of the chassis of the towing vehicle if at all possible. Slip the end of the hook through the neoprene keeper to prevent the hook from unhooking. (See Fig. 3)
4. Adjust slack so that the cables cannot touch the ground or become caught beneath the receiver area. If either of these things happen, the cables may become damaged and ineffective. **DO NOT USE DAMAGED CABLES!**
5. Be sure each cable or chain used has at least the load rating of the tow bar.



Strong As An Ox™

TOW BAR INSTALLATION (Towing Vehicle)

1. Slide the hitch connector into the receiver tube of your towing vehicle hitch. Secure the receiver pin provided into one of the two holes of the hitch receiver. The inside hole of the receiver tube is most commonly used. (Figure 1) Blue Ox offers receiver and towbar lock sets (BX88101) (BX88177) that help prevent theft. Contact Blue Ox for more information.
2. Proceed with hooking up towed vehicle. (Page 3)
3. **DEALER OR INSTALLER: BE CERTAIN USER RECEIVES INSTRUCTION SHEETS.**

NOTE: The configuration of the rear of your towing vehicle will determine how far you can slide the hitch connector into the receiver tube. Later, when the tow bar is folded, you may need to change which set of holes are used in the hitch connector or order a longer hitch connector. Longer and shorter hitch connectors are shown on page 6.

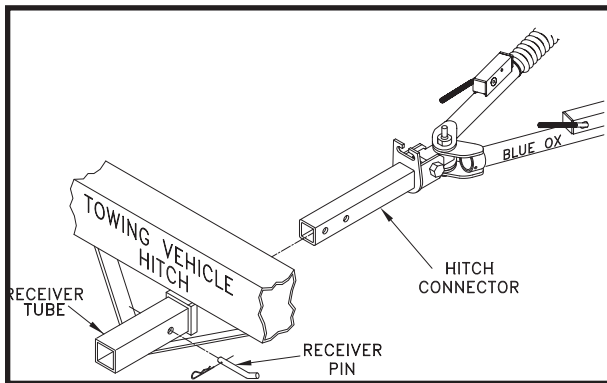

Figure 1

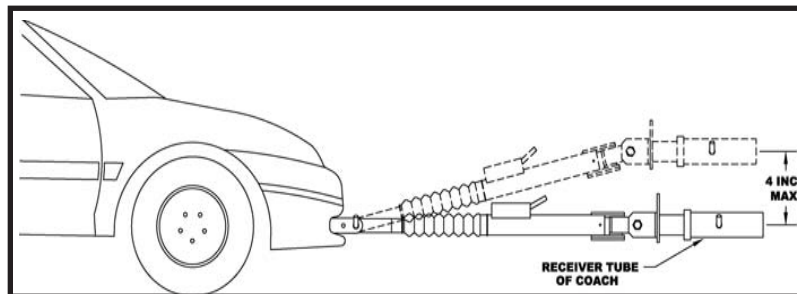

Figure 2

INSTALLATION

CAUTION: As with any mechanical product, care should be taken during installation and operation, to prevent your fingers from being pinched.

WARNING: Ensure that your towing vehicle is of adequate size to properly control your towed vehicle. The weight and braking capacity should be large enough to handle both vehicles in an emergency situation. Check your towing vehicle manufacturers recommendations for towing, hitch load, and braking capacities. The hitch, ball, motorhome chassis, and safety cables (each individual cable) need to be rated at a minimum for the weight of the vehicle being towed.

CAUTION: It is important that the attachment points at the center of the attachment tabs and the center of the coach's hitch receiver should be of equal distance. If a deviation must be present, it should be no more than four (4) inches from the tabs up to the hitch receiver. There should be no deviation allowed for the hitch receiver tube to be below the level of the attachment tabs. Refer to Figure 2.



Strong As An Ox™

HOOKING UP / EXTENDING TOW BAR

HOOKING UP (Towed Vehicle)

1. Position the towing vehicle on a level surface with a straight driveway ahead and engage the parking brake. (Later, You will be driving straight ahead to latch the legs when extending the tow bar.) Position the towed vehicle behind the towing vehicle in the approximate towing position and engage the parking brake of the towed vehicle.
2. Rotate the tow bar legs to the opposite side of the stored position until the hold up bolt is centered with the slot in the hitch connector. Push the tow bar legs towards the towing vehicle while raising them to allow the hold up bolt to clear. If the hold up bolt does not align with the gap, rotate the tow bar farther. Pull the legs out away from the towing vehicle and place them on the ground. **NOTE:** The hold up bolt will pass through the gap in the hitch connector when the legs are pulled out from the towing vehicle. See Figure 4.

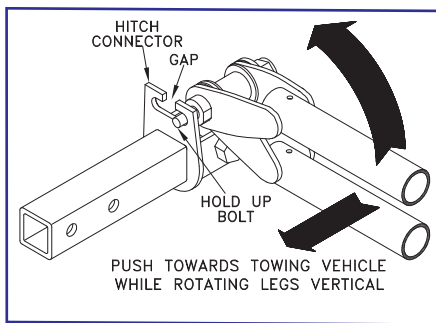

Figure 4

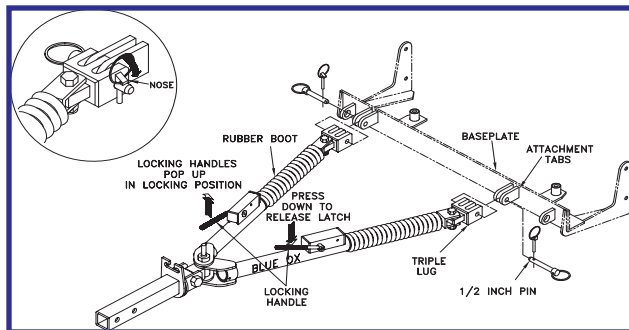

Figure 5

3. Partially extend one leg. The legs are held in with an internal "soft" latch. Pulling out on the leg will disengage this latch. Place the triple lug between the attachment tabs on the baseplate, and secure with the 1/2" pin. See Figure 5. Be sure to the 1/2" pin is installed **correctly** through the attachment tab with the nose towards middle of the baseplate. See Figure 5. Repeat for both legs.

EXTENDING TOW BAR



Caution: It is possible to extend the tow bar by driving away with the towing vehicle. This can cause the towed vehicle to wander from side to side and does not insure that the legs will lock into position. We **DO NOT recommend towing any vehicle until the operator has confirmed that the leg latches have been properly locked** as outlined in step 4.

4. On the towed vehicle disengage parking brake and set up the transmission for towing, see **Safety** section on Page 1 and unlock the steering wheel. Pull forward with the towing vehicle until one of the locking handles are engaged and locked. (When locked they will "pop" up)

NOTE: If only one locking handle is locked, turn the top of the towed vehicle's steering wheel towards the unlocked tow bar leg approximately 1/2 to 3/4 turn, before continuing forward. Pull the towing vehicle forward one to two feet until the leg locks into place. **IMPORTANT:** Check to insure both legs are latched properly before towing. The steering wheel on the towed vehicle must be unlocked at all times while being towed. Failure to do so will create hazardous driving conditions.

5. Install safety cables or chains and lighting. (See **Safety Cable Installation** - Page 1).



UNHOOKING TOW BAR / MAINTENANCE

Unhooking / Folding:

1. Park the towing vehicle with vehicle in tow, **in a straight line, on a flat, level surface** to insure minimum pressure is exerted on the tow bar legs.

This will aid in the removal of the 1/2" pins. Engage the towing vehicle parking brake. Place the towed vehicle either in park for automatic transmissions or securely in first gear for manual transmissions. Unhook the lighting and safety cables.

2. Disengage the leg latches by pushing down on the locking handles. (Figure 5) Remove the quick pins and 1/2" pins attaching the triple lugs to the attachment tabs. You may need to tap the 1/2" pins out if there is still pressure on them. Compress both legs completely until they lock in place.

NOTE: Each leg is equipped with a "soft" latch inside the end. Push in on each leg until they are held in detent by the soft latch.

NOTE: Place the 1/2" pins back into the triple lugs and secure with the quick pin assemblies to avoid losing either of them.

3. With legs together, swing them up towards the towing vehicle until the hold up bolt passes through the

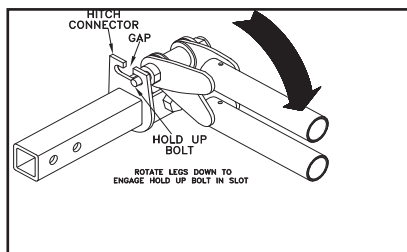

Figure 6

gap in the hitch connector. (Figure 6) Rotate the legs down to either side until the hold up bolt engages completely to the side of the hitch connector slot.

Tow Bar Maintenance

1. This tow bar requires periodic maintenance. It will be subjected to road dirt and weather during use. The following tips will help maintain the condition of your new tow bar.
2. Keep the tow bar covered when not in use, on or off of the towing vehicle. This will cut down on the dust and dirt build up on the legs and latches of the tow bar. A BX8875

tow bar cover is recommended.

3. Periodically clean the entire surface of the tow bar with a mild soap and water solution. Wipe dry with a clean cloth.
4. Check and replace any loose, worn or damaged bolts, rubber boots or cap plugs.
5. Check for cracked welds and loose bolts on the baseplate, towed vehicle (where baseplate is bolted) and the hitch on the towing vehicle.
6. In normal straight line towing conditions, both legs will be in tension. Due to the design of the latch, both handles will feel loose. During turning, braking or parking one or both of the legs may be in compression. This will make the handles feel stiff or tight. Due to parking on slopes or the angle between the coach and the car, the two locking mechanisms could be in compression or tension or any combination of the two. Having one lock in tension and one in compression may give the operator the feeling that one leg is locked and one is not, when in fact whenever the legs are fully extended and the springs are holding the latch handles up, the legs are locked and ready to tow whether in tension or compression.

Lubrication

1. Approximately once per year or if it is difficult to move the legs in and out you should remove the small cable ties holding the rubber boots on the legs and slide the boots back. Wipe clean each inside leg and apply a light coat of multipurpose grease to insure smooth operation. Secure each boot back in place with an 8 inch nylon cable tie (available at most automotive and hardware stores). See Fig 7.

2. All other pivot points should be cleaned, sprayed with silicon and allowed to dry before using. If you are using the

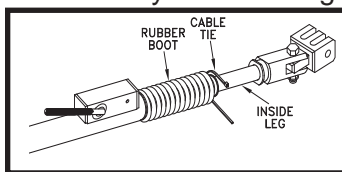

Figure 7

towbar in a harsh environment, these recommendations need to be done more often.



Strong As An Ox™

REPLACEMENT PARTS

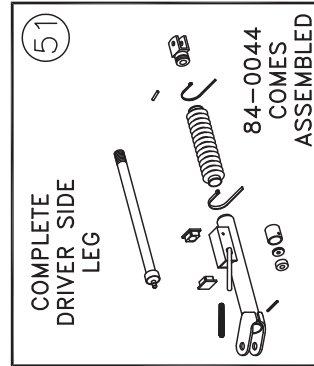
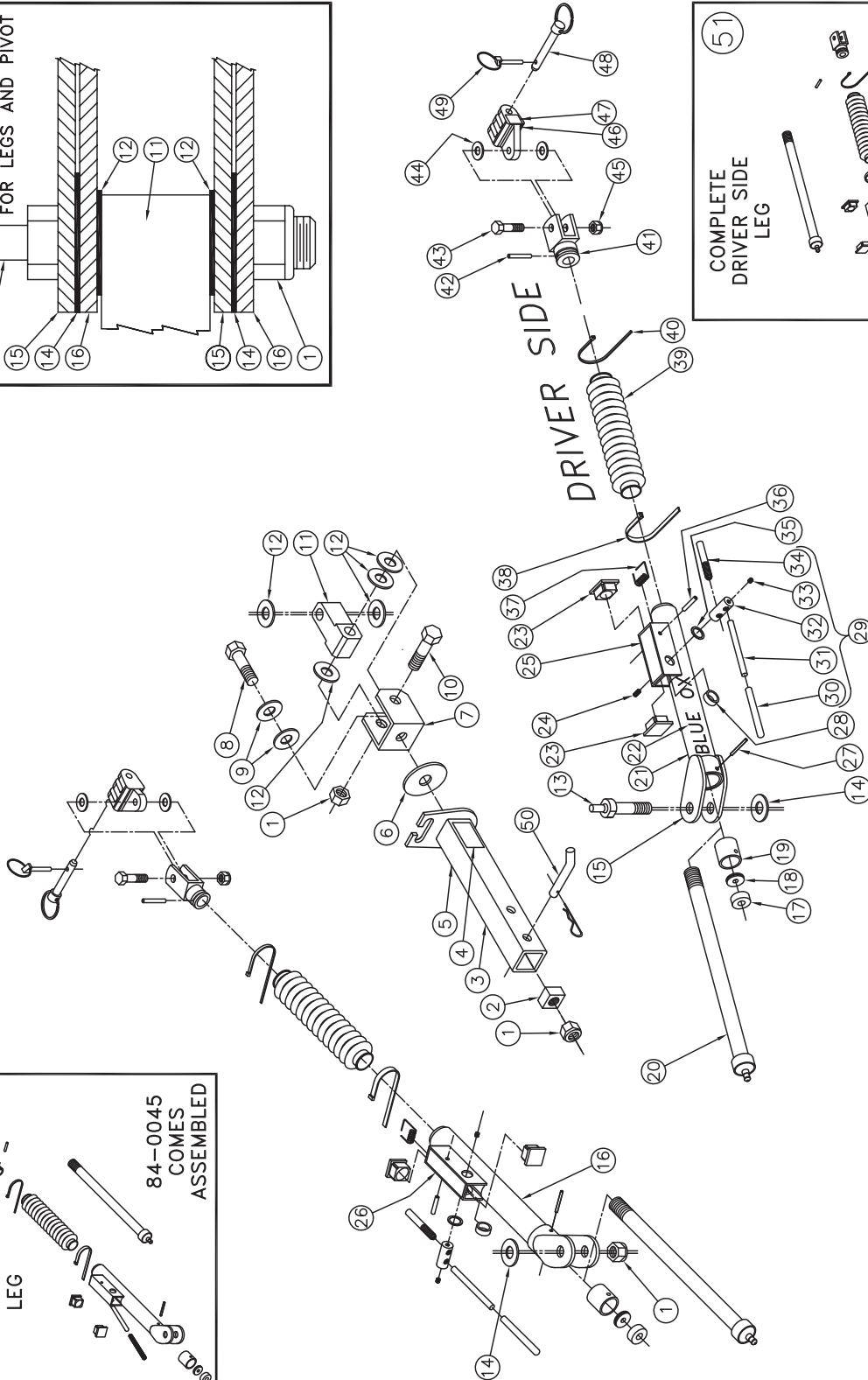
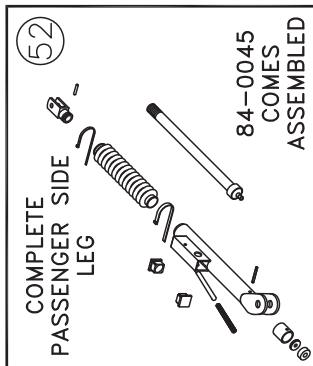
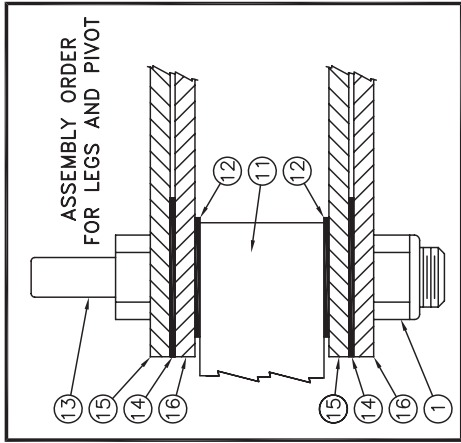

IMPORTANT: Use only genuine factory replacement parts on your Tow Bar. Do not substitute homemade or nontypical parts. If a bolt is lost or in need of replacement, for your safety and the preservation of your Tow Bar, be sure to use a replacement bolt of the same grade (Usually Grade 5).

Repair parts may be ordered through your nearest Blue Ox dealer or distributor.



Strong As An Ox™

REPLACEMENT PARTS

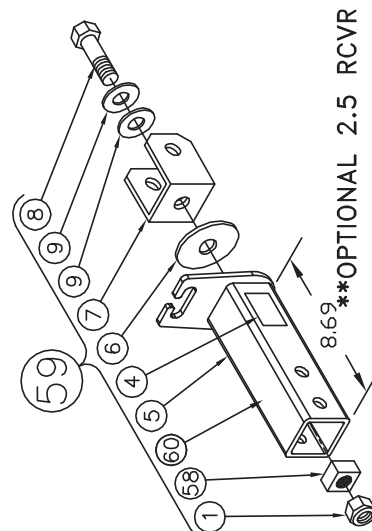
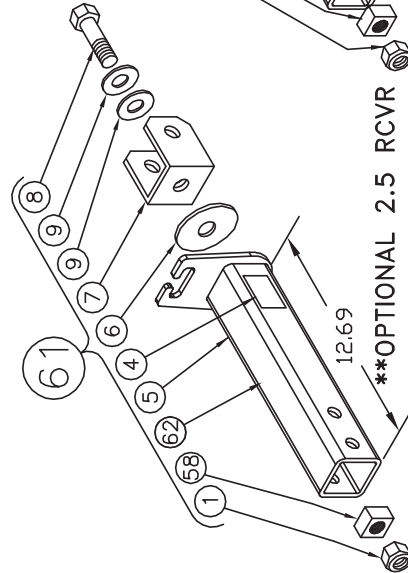
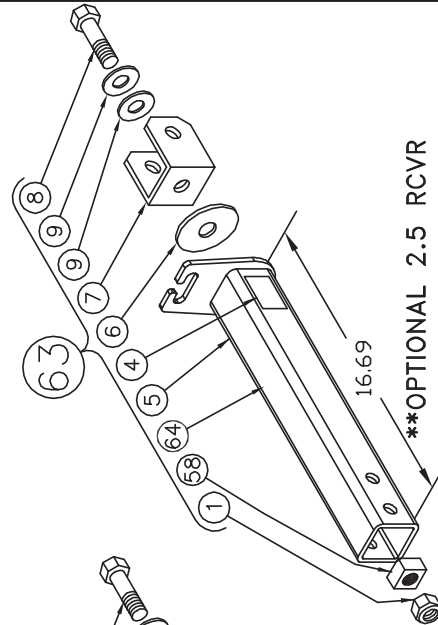
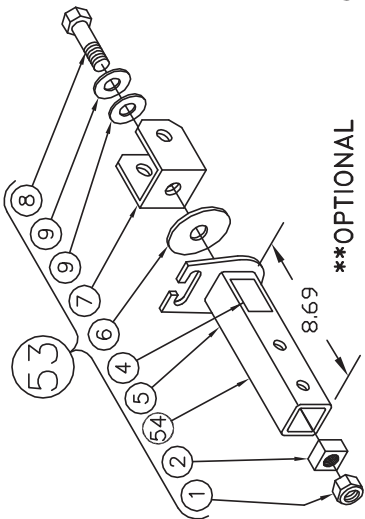
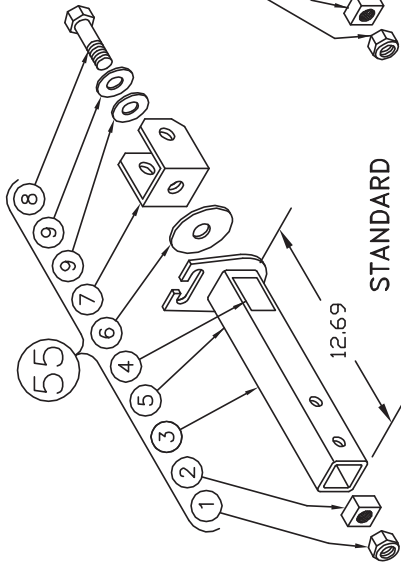
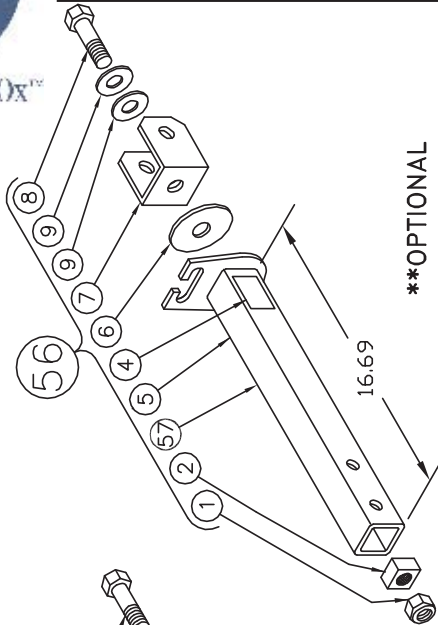



Strong As An Ox™

QUICK REFERENCE GUIDE

HOOKING UP & EXTENDING FOR TOWING

1. Align vehicles in towing position with straight driveway ahead and parking brakes locked.
2. Rotate legs up to unfold tow bar. Partially extend legs, pin double pivot lug between baseplate attachment tabs.
3. Drive towing vehicle forward until both legs are locked. (Locking Handles Up)
4. Install safety cables and towed vehicle lighting.

UNHOOKING & FOLDING FOR STORAGE

1. Park vehicles in a straight line on level surface. Apply towing vehicle parking brake. Place towed vehicle in park or 1st gear for manual transmissions.
2. Remove safety cables and towed vehicle lighting.
3. Disengage locking handles, remove quick pins and connector pins and replace to prevent loss.
4. Compress and place legs together, fold towards towing vehicle and rotate down to engage hold up bolt.
5. When unhooking in tight jams, put the vehicle in neutral. Turn the wheels all the way to one side, then all the way to the other and center.

Repair parts may be ordered through your nearest Automatic dealer or distributor.

Detailed instructions appear on page 5.

TO BE VALID, THE WARRANTY CARD MUST BE COMPLETED IN ITS ENTIRETY BY AN AUTHORIZED DISTRIBUTOR OR DEALER AND SENT TO AUTOMATIC EQUIPMENT MFG. CO., PENDER, NEBRASKA. FAILURE TO DO SO WILL VOID THE WARRANTY. TOWING BEHIND A NON-MOTORIZED VEHICLE WILL VOID THE WARRANTY.

Product Safety Policy Statement

It is, and shall continue to be, a primary objective of Automatic Equipment Manufacturing Company to provide customers with safe and reliable products. Automatic will, and has, established safety procedures in product design, manufacture, promotion and sales; and will coordinate efforts to promote customer safety to the greatest extent possible. Each department has primary responsibility for the promotion of safety under the guidelines of the Product Safety

⚠ WARNING: Ensure that your towing vehicle is of adequate size to properly control your towed vehicle. The weight and braking capacity should be large enough to handle both vehicles in an emergency situation. Check your towing vehicle manufacturers recommendations for towing, hitch load, and braking capacities. The hitch, ball, motorhome chassis, and safety cables (each individual cable) need to be rated at a minimum for the weight of the vehicle being towed.

If the tow bar is in an accident, it must be replaced. **DO NOT** use it again! An accident can cause unseen damage and using it again could result in more damage or serious injury. **DO NOT** use the tow bar if it is damaged or missing parts.