



Installation Instructions



PowerBoard®







Automatic Retracting Running Board

Vehicle Application

- Dodge Ram Quad Cab Pickup 2002 - 2008
Part Number: 75101-15
- Dodge Ram Mega Cab Pickup 2006 - 2009
Part Number: 75118-15
- Dodge Ram Quad Cab Pickup, 2500 / 3500 / HD 2003 - 2009
Part Number: 75101-15

www.Bestop.com - We're here to help! Visit our web site and click on "Ask a Question". Click here for more [Truck Accessories by Bestop](#).

INSTALLATION TIME  4 Hours	SKILL LEVEL  4 - Difficult
---	---

TOOLS				
Tape Measure 	Flat-Head Screwdriver 	Phillips Screwdriver 	Power Drill  1/8" Drill Bits	Wrench  13 mm
Crimp Tool 	Paint 	Allen Wrench  5mm	Rivet Gun 	Safety Glasses 



- ! WARNING** The manufacturer strongly recommends that this product be professionally installed.
- ! WARNING** Failure to carefully follow the electrical installation steps could result in severe electrical shock which could harm the installer and/or damage the vehicle.

- ! WARNING** Do not rely in any way on the components of this product to protect against injury or death in the event of an accident. Never operate the vehicle in excess of manufacturer's specifications.
- WEAR SEAT BELTS AT ALL TIMES**
- Read and follow, precisely, all installation instructions provided when installing product. Failure to do so may result in a poor fit and could place occupants of the vehicle in a potentially dangerous situation.

PowerBoard® – Installation Instructions

Parts List and Hardware Identification

Left End Cap, Part Number 460.83, Qty - 1

Running Board Assembly, Qty - 2
72" - Part Number 473.14
79" - Part Number 460.87

Posi-Tap, Part Number 470.03, Qty - 4

M6-1.0 x 10mm Socket Cap Screw, Part Number 460.85, Qty - 2

T-Nut Insert, Part Number 460.84, Qty - 2

M6 Nut Plate, Part Number 460.86, Qty - 2

Right End Cap, Part Number 460.82, Qty - 1

Motor Linkage, Part Number 473.38, Qty - 2

Motor (for use with Blue Controller), Part Number 496.12, Qty - 2

Front Mounting Bracket, Part Number 473.31, Qty - 2

Idle Linkage, Part Number 473.37, Qty - 2

M6-1.0 x 35 Socket Cap Screw, Part Number 460.95, Qty - 6

M6 Flat Washer, Part Number 481.96, Qty - 6

M6-1.0 x 20 mm Socket Head Bolt, Part Number 470.00, Qty - 8

1/8" x 1/2" Rivet, Part Number 474.80, Qty - 8

11" Cable Ties, Part Number 470.02, Qty - 2

7" Cable Ties, Part Number 460.99, Qty - 25

Wiring Harness, Part Number 473.34, Qty - 1

Light, Part Number 470.15, Qty - 4

Blue Controller, Part Number 496.11, Qty - 1

Mounting Bracket Support Nut, Part Number 473.35, Qty - 4

Damper Bracket Kit, Part Number 475.66, Qty - 1 (Only needed for Quad Cab)

NOTE The 473.31 Front Mounting Brackets come pre-attached to the 473.38 Motor Links with the Hex bolts. Remove the brackets from the links before continuing with the installation.

PowerBoard® – Installation Instructions

NOTE Quad Cab Only -

Before beginning this installation, follow the instructions in the Damper Bracket Kit to relocate the dampers on 1500 Quad Cabs.

1 Remove Plugs - Driver's Side

Counting from the front, locate the third (3rd) and seventh (7th) plugs on the inner sill for a Quad Cab. For a Mega Cab locate the third (3rd) and eighth (8th) plugs. Use a flat screwdriver to pry them out.

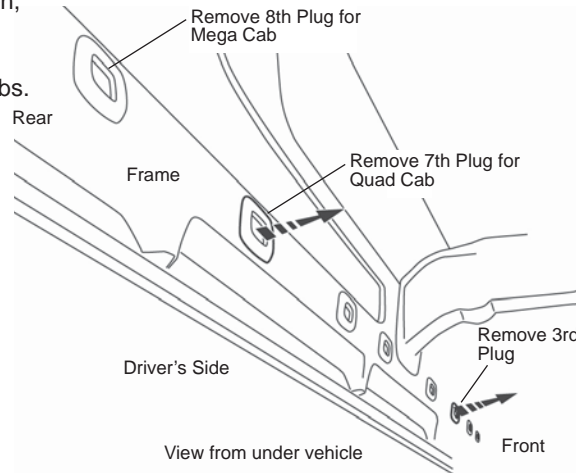

2 Assemble Rear Mounting Bracket Assembly - Driver's Side

Locate the Rear Mounting Brackets and the Mounting Bracket Support Nuts in the parts kit. Use a Medium Hex Bolt to attach a Support Nut to the back of the Rear Mounting Bracket.

If you have a Mega Cab, remove the tape and cut as indicated for the Mega Cab Rear Bracket, if necessary.

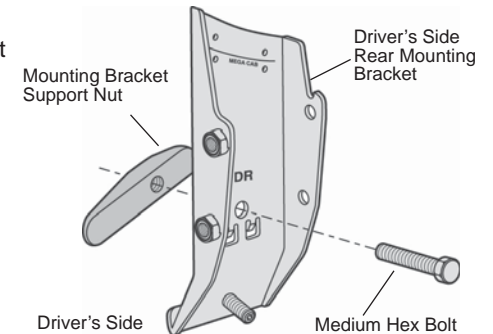

3 Install Rear Mounting Bracket Assembly - Driver's Side

Slide the Support Nut on the Rear Mounting Bracket Assembly into the rear hole where the plug was removed. Hook the tabs on the bracket over the edge of the hole to help secure the bracket to the frame. Pull back on the Hex Bolt to snug the nut and bracket up to each other and use a 13mm wrench to tighten the bolt to 16 ft./lbs. (22 Nm).

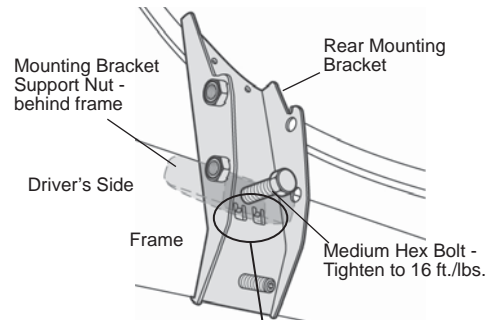

NOTE Make sure that the two tabs in the bracket rest on the edge of the hole in the sheet metal.

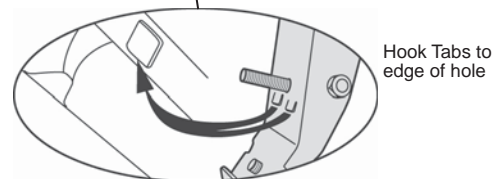

4 Install Rear Mounting Bracket Assembly - Driver's Side

Use the two small holes in the Rear Mounting Bracket as templates to drill two 1/8" holes. Paint the edges of the holes with Corrosion Protection Paint to prevent rust.

Install a Rivet in each hole. Use a 1/8" Allen Wrench to tighten the set screw on the bracket to 1.5 ft./lbs. (2 Nm).

NOTE Make sure the bracket is flush with the inner sill before riveting.

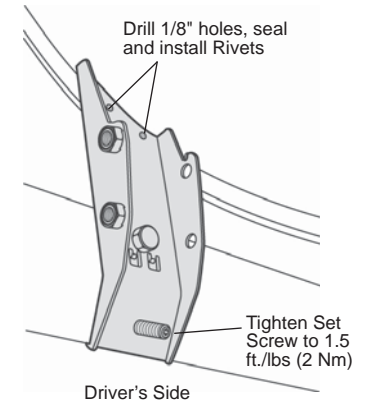

PowerBoard® – Installation Instructions

5 Install Front Mounting Brackets

Repeat Steps 1-4 with the Front Mounting Bracket.

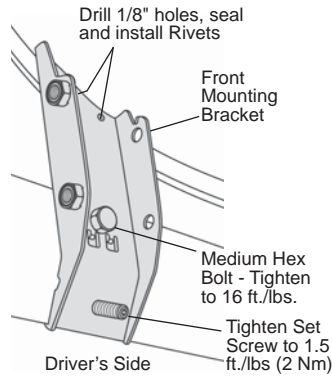

6 Install Arms - Driver's Side

Orient the Front and Rear Arms to the brackets so the platform faces outside the vehicle to support the Step. Install the arms in the brackets with two Large Hex Bolts for each arm. Tighten the bolts to 16 ft./lbs. (22 Nm).

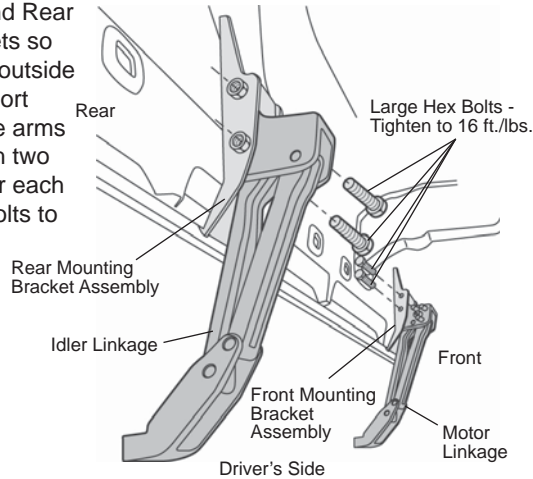

7 Install Passenger's Side Brackets and Arms

Repeat Steps 1-6 on the passenger side.

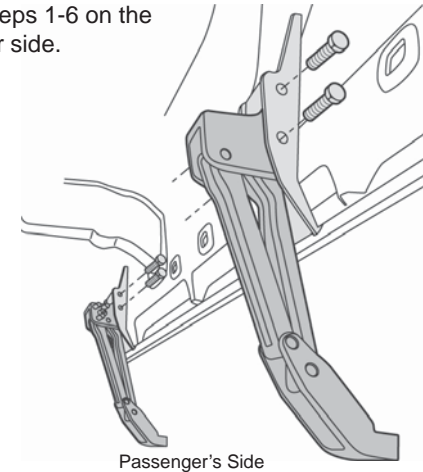

8 Install Controller and Wiring Harness

Loosely wrap 11" Cable Ties around harness in engine compartment. Slide the Controller through the Cable Ties and tighten. Attach the Wiring Harness to the Controller.

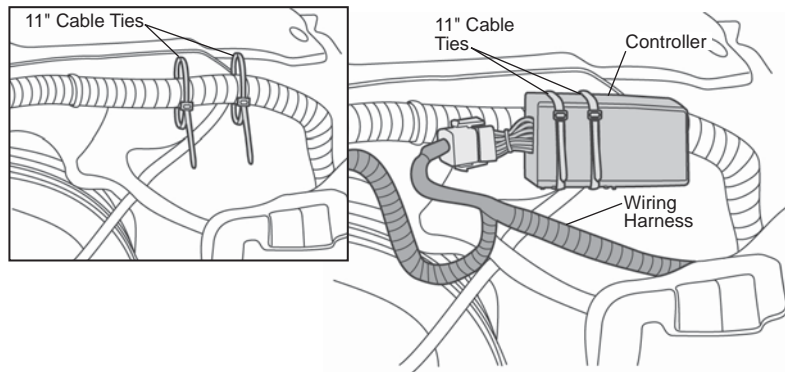

! WARNING Remove the fuse from the Wiring Harness.

9 Remove Fuse from Wiring Harness

Remove the fuse from the Wiring Harness. Failure to do so could result in severe electrical shock which could harm the installer and/or damage the vehicle.

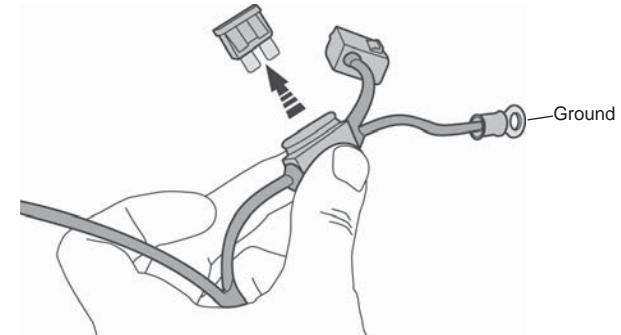

PowerBoard® – Installation Instructions

10 Attach Power Leads

Attach the red power lead to the positive battery terminal and black lead to the body ground.

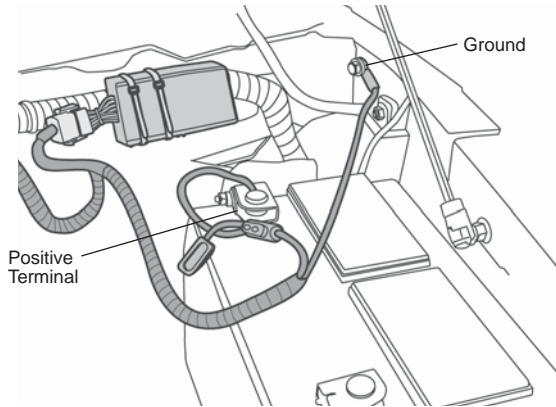

11 Secure Wiring Harness

Route the longer leg of the harness that terminates in a plug across the front of the engine compartment and down to the motor on the passenger side step. Route the shorter leg to the motor on the driver's side step. Use the 7" Cable Ties in the parts kit to secure the harness out of the way.

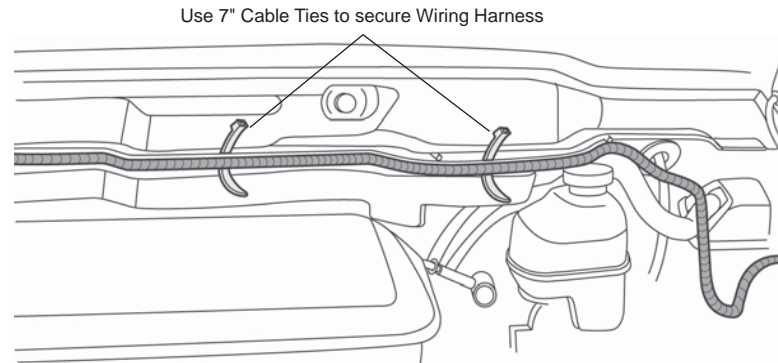

12 Install Wiring Harness

Route the leg of the Wiring Harness with the unterminated wires down to the grommet access through the firewall. Drill a hole in the grommet and feed the wires through the firewall.

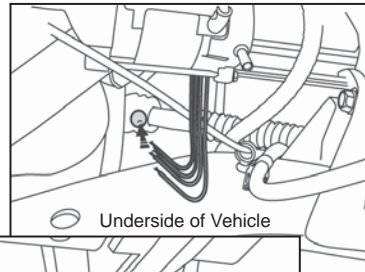
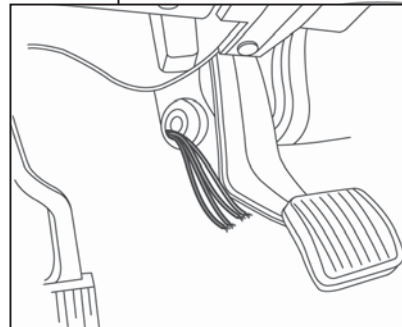
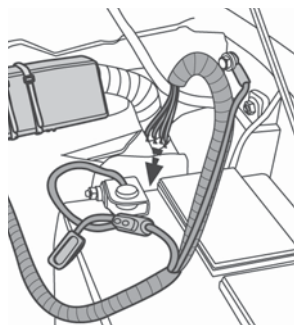

13 Remove Plastic Panels

Remove the plastic panels below the steering wheel. Remove the metal panel under the plastic panel. Model years 2002 - 2005 will not have this panel.

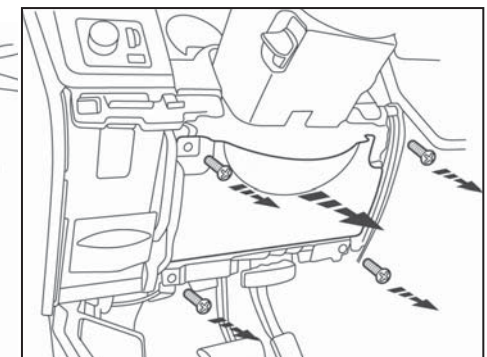
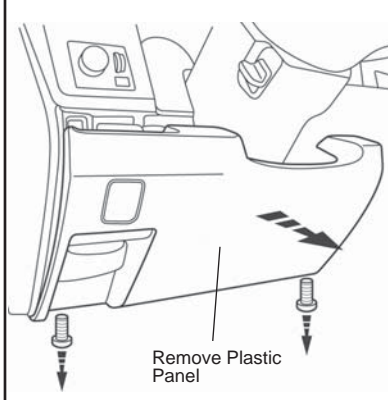

PowerBoard® – Installation Instructions

14 Locate Wiring Harness

Locate the bundle of wires high and to the left of the steering column, behind the dash light dimmer switch. 2002 - 2005 model years will find this bundle running down the right side of the steering column.

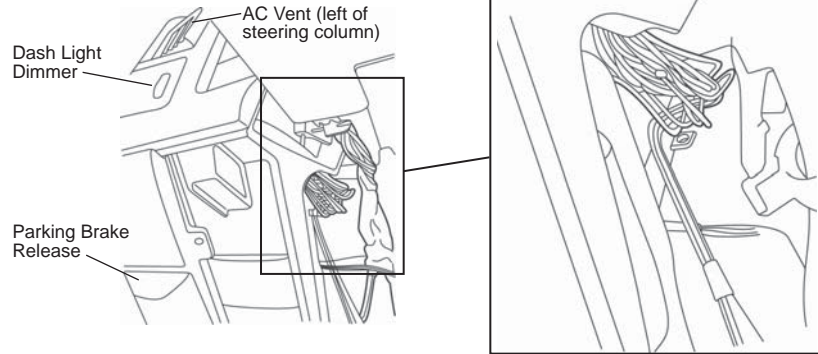

15 Install Wiring Harness

Pull the unterminated wires of the harness up to the harness.

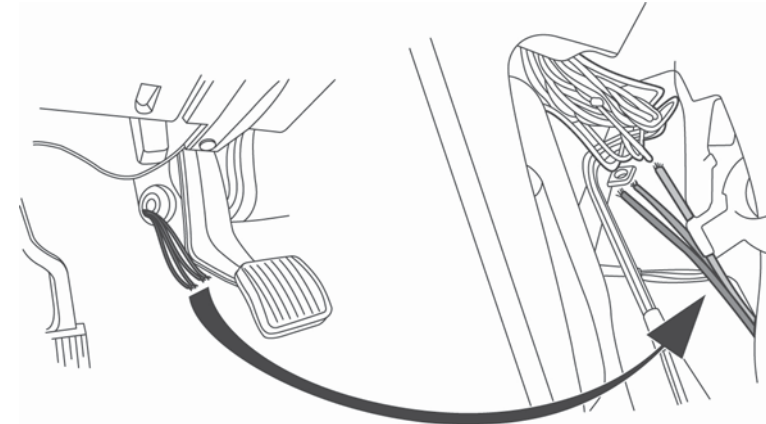

16 Wiring

Use the Posi-Taps™ to splice the PowerBoard® trigger wires into the door ajar wires indicated for your vehicle model year.

NOTE 2004 - 2009 model years may have two (2) VI/YL wires in the bundle. Only one will work correctly.

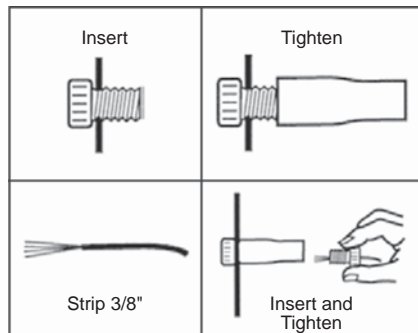

Posi-Tap™ Instructions

2004 – Current

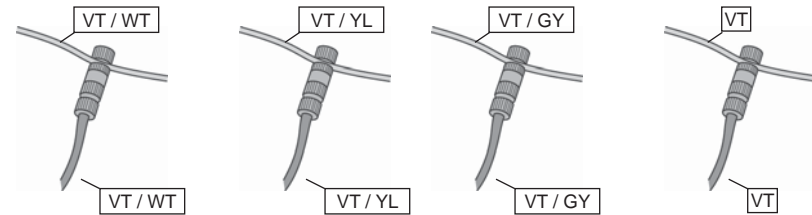

2002 – 2003

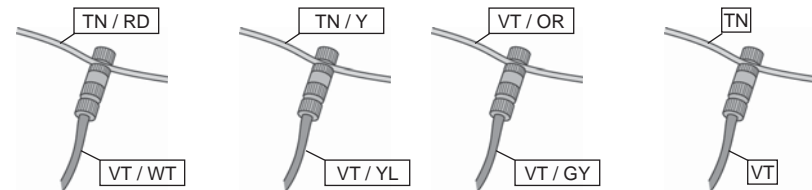

NOTE Occasionally the actual wire color may be different than stated here. You will need to install to the motor and test each wire until you find the wire that functions correctly.

PowerBoard® – Installation Instructions

17 Install Wiring Harness

Route harness to motors and secure under vehicle with 7" Cable Ties.

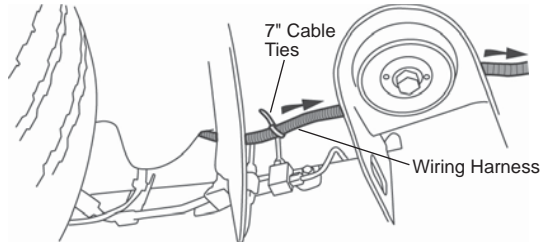

18 Install Lights

Clean the outboard surface of the of the Linkage below the bottom mounting bolt. Peel the adhesive liner off the back of the Light and firmly press it 1/8" below the mounting bolt. Plug the light into the connector with the black and orange wires in the wire harness. Repeat with the other three lights. Secure loose wires with Cable Ties.

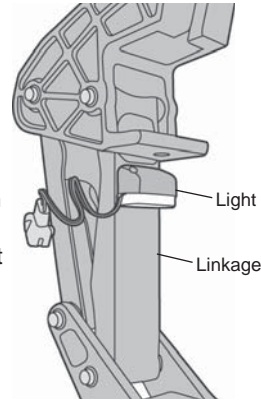

22 Install Running Boards

Mount the Steps to the linkages. Slide the mounting T-Nut into position. Install M6-1.0 x 20mm Socket Head Bolts to secure the boards. Use a 5mm Allen Wrench to tighten the bolts.

Make sure the board moves up and down freely by hand. If it binds, loosen the linkage to body attachment bolts and adjust the linkage position until the boards move freely. **Do not tighten the bolts at this time.**

NOTE *Tightening the fasteners before cycling the step several times may create a bind, causing a squeaking sound and preventing the boards from retracting completely and evenly.*

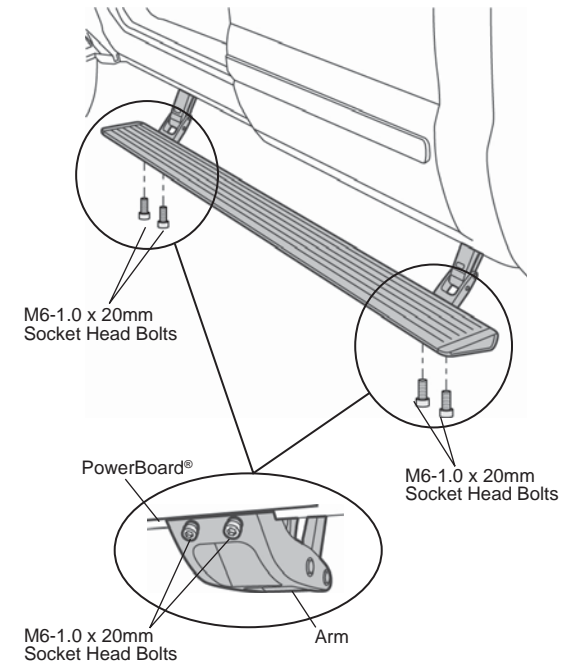

20 Install Motor

Slide Motor assembly onto drive shaft and mounting bosses of Motor Linkage assembly. Use three (3) M6-1.0 x 35mm Socket Cap Screws and M6 Flat Washers to secure Motor. Plug female connector into Motor. Wrap any exposed wires from the motor with electrical tape. Torque the screws to 5–7 ft. lbs. (6.78–9.49 Nm or 60-84 in. lbs.).

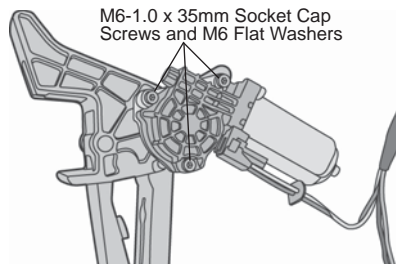

21 Reinstall Fuse

Reinstall the fuse in the harness.

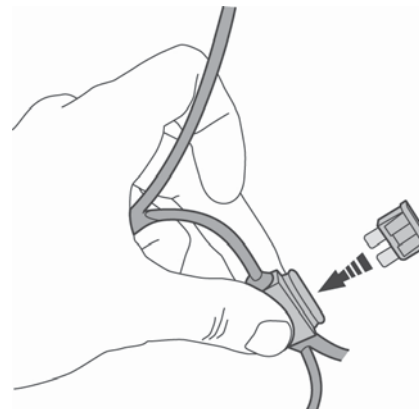

PowerBoard® – Installation Instructions

23 Test Doors and PowerBoards®

Open the doors to make sure that the PowerBoard® drops into position on each side of the vehicle.

Reinstall any remaining trim panels.

Cycle boards several times and then fully tighten all bolts.

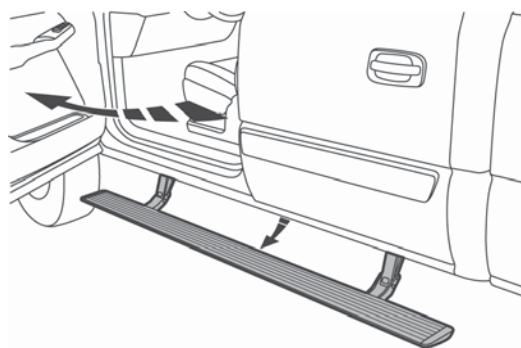

PowerBoard® Troubleshooting

Issue:

- Possible cause

Boards do not operate:

- Connected to incorrect vehicle wire
- Wire connections not secure
- Fuse burned
- Factory door-ajar circuit inoperable

Board creaks or squeaks during operation:

- Gear shaft wedge bolt is loose
- Loosen mounting bracket and board attachment screws. Adjust linkages so they are parallel to each other and the noise is gone. Tighten all fasteners.

Intermittent operation:

- Wire connections not secure
- Bad ground
- Bad battery connection

Boards operate randomly:

- Wire connections not secure
- Connected to incorrect vehicle wire

Board stays down all the time and can be moved by hand:

- Gear shaft wedge screw is missing or loose

Board shakes and or shutters during operation:

- Bad ground
- Wire connections not secure
- Bad battery connection

One or more doors operate the board and other do not:

- Wire connections not secure

PowerBoard® Service Tips

Confirming PowerBoard® is functional-black controller:

To test if the black controller (460.91), wire harness, motor and lights work, hook up to battery and touch any of the 4 door trigger wires to ground. The board for that side should go down and the lights should turn on. The board should go up and the lights should turn off when the wire is removed from ground.

Boards don't operate correctly when connected to wires identified in instructions:

Unfortunately vehicle manufactures do not consistently keep the same wire colors in their wire harnesses. The PowerBoard® trigger wires need to be connected the factory door-ajar wire that is connected to each door latch switch. The correct wire is likely in the same bundle that is identified in the instructions. If none of them work you can locate the correct wire by removing the door panel and tracing the wire bundle that leads to the door latch.

Use an ohm meter or continuity tester to find the door-ajar wire on PowerBoard®s with black controllers. The correct wire will go from neutral to ground when the door is opened and return to neutral when the door is shut. Connect one test lead to the negative battery terminal and probe the wires with the other lead. You can use a pin or a Posi-Tap connector to pierce the wire insulation. The correct wire will make the tester go from no continuity to complete continuity when the door opened and return to no continuity when the door is shut. You can also shut the door latch with the door open by pushing on the latch catch with a screw driver.

PowerBoard® – Installation Instructions

Linkage Component Identification

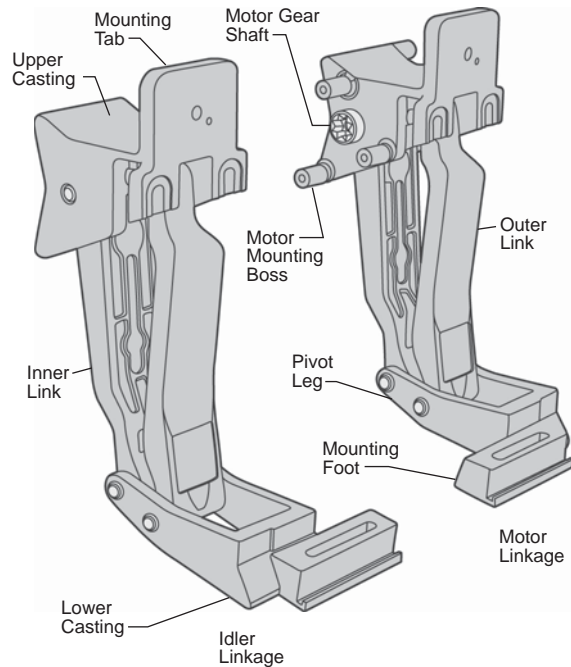

LIMITED WARRANTY

We warrant our product to be free from defects in material and workmanship, for the terms specified below, provided there has been normal use and proper maintenance. This warranty applies to the original purchaser only. All remedies under this warranty are limited to the repair or replacement of any item or items found by the factory to be defective within the time period specified. If you have a warranty claim, first you must call our factory at the number below for instructions. You must retain proof of purchase and submit a copy with any items returned for warranty work. Upon completion of warranty work, if any, we will return the repaired or replaced item or items to you freight prepaid. Damage to our products caused by accidents, fire, vandalism, negligence, misinstallation, misuse, Acts of God, or by defective parts not manufactured by us, is not covered under this warranty.

THE WARRANTY TIME PERIOD IS AS FOLLOWS FOR ALL PowerBoards® MANUFACTURED BY OUR COMPANY: THREE YEARS / 36,000 MILES FROM DATE OF PURCHASE.

ANY IMPLIED WARRANTIES OF MERCHANTABILITY AND/OR FITNESS FOR A PARTICULAR PURPOSE CREATED HEREBY ARE LIMITED IN DURATION TO THE SAME DURATION AND SCOPE AS THE EXPRESS WRITTEN WARRANTY. OUR COMPANY SHALL NOT BE LIABLE FOR ANY INCIDENTAL OR CONSEQUENTIAL DAMAGE.

Some states do not allow limitations on how long an implied warranty lasts, or the exclusion or limitation of incidental or consequential damages, so the above limitations or exclusions may not apply to you. This warranty gives you specific legal rights, and you may also have other rights which vary from state to state.

For further information or request for warranty work, please contact:

Bestop Inc. Customer Service
Toll-Free: (800)845-3567
Main: (303)465-1755
E-mail: csbestop@Bestop.com
Website: www.Bestop.com

