



PERFORMANCE EXHAUST SYSTEM

APPLICATION

YEAR	MODEL
2008-2009	Can-Am Spyder GS
2010-2012	Can-Am Spyder RS

PRODUCT

1530202	Stainless Steel Slip-on Exhaust System with Carbon Fiber Sleeve
1530205	Stainless Steel Slip-on Exhaust System with Stainless Steel Sleeve

- ⚠ This product is designed for use in closed course racing and is not intended for highway use. In the state of California, it is illegal to modify the emission control system, which includes the fuel injection of any vehicle.
- ⚠ You must know how to remove and replace your stock exhaust in order to install this product otherwise have it installed by a professional mechanic. Keep all stock parts from your existing system as some components may be necessary to install your new Yoshimura exhaust depending on the application.
- ⚠ Read through all instructions before beginning installation. Exhaust system can be extremely hot. Let motorcycle cool down before beginning installation. Always wear hand and eye protection and take precautionary measures to avoid injury.

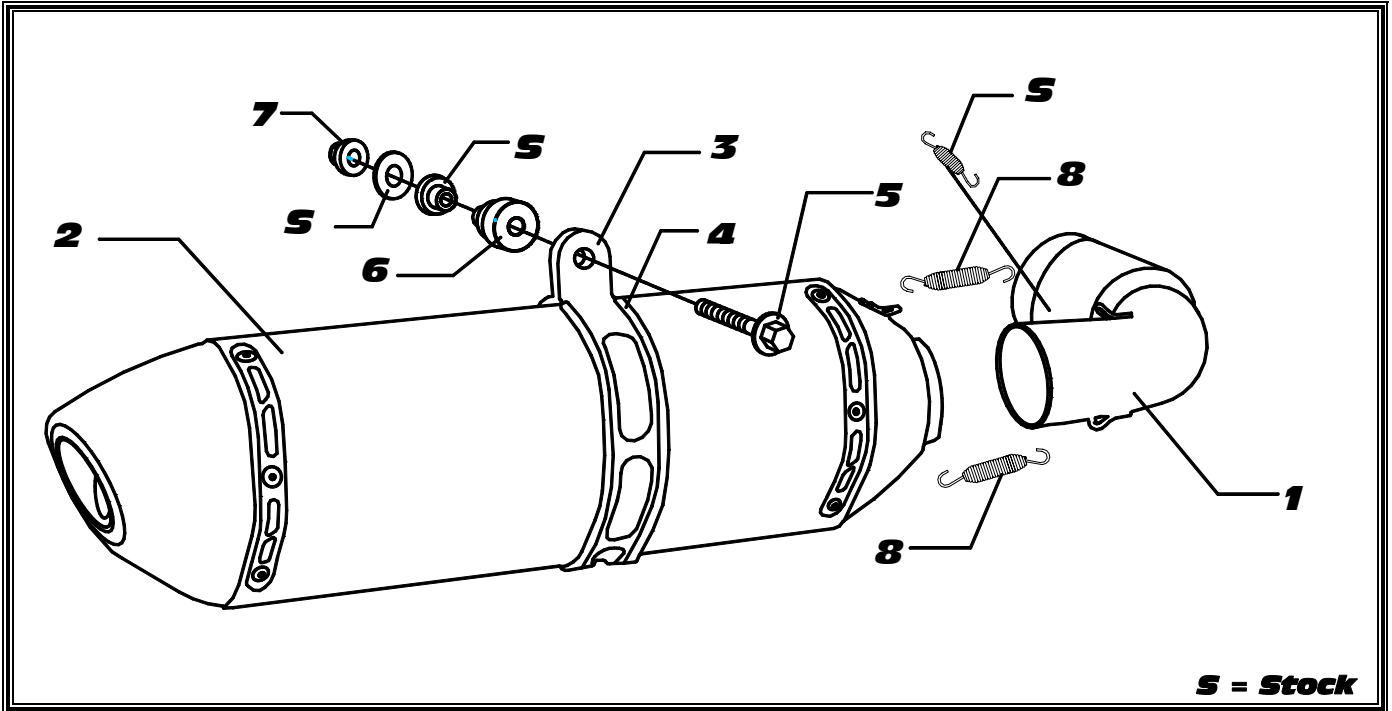

S = Stock

No.	Part #	Description	Qty
1	1530-435	Yoshimura Tailpipe	1
2	1195002-RMA 1530205-RMA	Yoshimura Muffler Carbon Fiber Sleeve Stainless Steel Sleeve	1
3	1426-MPCA 1426-MPCAX	Muffler Clamp Carbon Fiber Sleeve Stainless Steel Sleeve	1
4	HT SHLDR77	Clamp Heat Shield	1

5	M10X60H	10mm x 60mm Bolt	1
6	ALS-026	Aluminum Spacer	1
7	10MMFNUT	10mm Flanged Nut	1
8	RACE-82mm	Spring w/ Insulator 2.6"	2
**	ST-200	Spring Puller Tool	1
**	INS-04-K	Low Volume Insert	1
**	17029	Yoshimura Sticker Sht	1

-TOOLS REQUIRED-

Metric Socket Set

Combination Wrench Set

Torque Wrench

Allen Wrench Set

-REMOVAL-

1. Removing the stock muffler.

- a) Remove the (3) screws mounting the heat shield to the muffler.**
- b) Remove stock muffler spring on the tailpipe and "Y" pipe using the spring puller tool.**
- c) Loosen tailpipe clamp and slide down towards muffler spring hook.**
- d) While supporting muffler, remove muffler mounting bolt and stock spacer on the right side passenger footrest support.**
- e) Remove stock muffler and tailpipe from "Y" pipe. Remove stock tailpipe clamp and place aside for use with Yoshimura tailpipe.**
- f) Inspect old muffler gasket on "Y" pipe and replace if necessary. ('08 p/n: 707600350, '09-'12 p/n: 707600547)**

-INSTALLATION-

1. Installing the Yoshimura muffler tailpipe assembly.

- a) Install rubber heat shield on clamp.**
- b) Insert stock tailpipe clamp over Yoshimura tailpipe.**
- c) Insert muffler tailpipe assembly on "Y" pipe.**
- d) Assemble and install bolt, spacer, and nut (provided in kit) on muffler bracket and bolt on footrest support. See diagram for orientation. Torque to 14 lb-ft. (18 N-m)**
- e) Tighten muffler clamp and torque to 24 lb-ft. (32 N-m)**
- f) Re-install the stock spring to the tailpipe and "Y" pipe using the spring puller tool.**

2. Fitment check and Notes.

- a) Before starting motorcycle, check for proper clearance and be sure nothing is binding or hitting. If any problem is found, please carefully follow through the installation steps again. If problem still persists, please call Yoshimura Tech Department at (800) 634-9166 / in CA (909) 628-4722.**
- b) It is recommended that the muffler and tailpipe be wiped down with rubbing alcohol to remove oil and fingerprints. This will help prevent tarnishing of the finish after the exhaust is heated up.**
- c) NOTE: After starting motorcycle, it is normal for new exhaust system and muffler to emit smoke until oil residue burns off.**