



Installation Instructions: S&S® Original Equipment Specification (OES) Gear Drive Cams for Harley-Davidson® Twin Cam 88® Engines 1999–2006 Big Twin, except 2006 Dyna® models

DISCLAIMER:

S&S parts are designed for high performance, closed course, racing applications and are intended for the very experienced rider only. The installation of S&S parts may void or adversely affect your factory warranty. In addition such installation and use may violate certain federal, state, and local laws, rules and ordinances as well as other laws when used on motor vehicles used on public highways, especially in states where pollution laws may apply. Always check federal, state, and local laws before modifying your motorcycle. It is the sole and exclusive responsibility of the user to determine the suitability of the product for his or her use, and the user shall assume all legal, personal injury risk and liability and all other obligations, duties, and risks associated therewith.

The words Harley®, Harley-Davidson®, H-D®, Sportster®, Evolution®, and all H-D part numbers and model designations are used in reference only. S&S Cycle is not associated with Harley-Davidson, Inc.

SAFE INSTALLATION AND OPERATION RULES:

Before installing your new S&S part it is your responsibility to read and follow the installation and maintenance procedures in these instructions and follow the basic rules below for your personal safety.

- Gasoline is extremely flammable and explosive under certain conditions and toxic when breathed. Do not smoke. Perform installation in a well ventilated area away from open flames or sparks.
- If motorcycle has been running, wait until engine and exhaust pipes have cooled down to avoid getting burned before performing any installation steps.
- Before performing any installation steps disconnect battery to eliminate potential sparks and inadvertent engagement of starter while working on electrical components.
- Read instructions thoroughly and carefully so all procedures are completely understood before performing any installation steps. Contact S&S with any questions you may have if any steps are unclear or any abnormalities occur during installation or operation of motorcycle with a S&S part on it.
- Consult an appropriate service manual for your motorcycle for correct disassembly and reassembly procedures for any parts that need to be removed to facilitate installation.
- Use good judgment when performing installation and operating motorcycle. Good judgment begins with a clear head. Don't let alcohol, drugs or fatigue impair your judgment. Start installation when you are fresh.
- Be sure all federal, state and local laws are obeyed with the installation.
- For optimum performance and safety and to minimize potential damage to carb or other components, use all mounting hardware that is provided and follow all installation instructions.
- Motorcycle exhaust fumes are toxic and poisonous and must not be breathed. Run motorcycle in a well ventilated area where fumes can dissipate.

IMPORTANT NOTICE:

Statements in this instruction sheet preceded by the following words are of special significance.



WARNING

Means there is the possibility of injury to yourself or others.



CAUTION

Means there is the possibility of damage to the part or motorcycle.

NOTE

Other information of particular importance has been placed in italic type.

S&S recommends you take special notice of these items.

WARRANTY:

All S&S parts are guaranteed to the original purchaser to be free of manufacturing defects in materials and workmanship for a period of twelve (12) months from the date of purchase. Merchandise that fails to conform to these conditions will be repaired or replaced at S&S's option if the parts are returned to us by the purchaser within the 12 month warranty period or within 10 days thereafter.

In the event warranty service is required, the original purchaser must call or write S&S immediately with the problem. Some problems can be rectified by a telephone call and need no further course of action.

A part that is suspect of being defective must not be replaced by a Dealer without prior authorization from S&S. If it is deemed necessary for S&S to make an evaluation to determine whether the part was defective, a return authorization number must be obtained from S&S. The parts must be packaged properly so as to not cause further damage and be returned prepaid to S&S with a copy of the original invoice of purchase and a detailed letter outlining the nature of the problem, how the part was used and the circumstances at the time of failure. If after an evaluation has been made by S&S and the part was found to be defective, repair, replacement or refund will be granted.

ADDITIONAL WARRANTY PROVISIONS:

- (1) S&S shall have no obligation in the event an S&S part is modified by any other person or organization.
- (2) S&S shall have no obligation if an S&S part becomes defective in whole or in part as a result of improper installation, improper maintenance, improper use, abnormal operation, or any other misuse or mistreatment of the S&S part.
- (3) S&S shall not be liable for any consequential or incidental damages resulting from the failure of an S&S part, the breach of any warranties, the failure to deliver, delay in delivery, delivery in non-conforming condition, or for any other breach of contract or duty between S&S and a customer.
- (4) S&S parts are designed exclusively for use in Harley-Davidson® and other American v-twin motorcycles. S&S shall have no warranty or liability obligation if an S&S part is used in any other application.

SPECIFICATIONS FOR S&S® GEAR DRIVE CAMSHAFTS FOR HARLEY-DAVIDSON® TWIN CAM 88® ENGINES										
Cam Name	Lobe	Timing		Duration	Lift	Centerline	TDC Lift	99-04 Models Works with stock valve springs	05-UP Models Works with stock valve springs	Works with stock pushrods
		Open	Close							
OES	Int	-2°	38°	216°	0.473"	110°	0.072"	X	X	X
	Exh	36°	4°	220°		106°	0.11"			

Chart 1

INTRODUCTION

Important Note: Pinion shaft run out must be verified before installing gear drive camshafts. (.003" max)

COMPATIBILITY NOTES:

- Pinion shaft run out must be verified before installing gear drive camshafts. (.003" max)
- S&S® Gear Drive Cams are not compatible with camshafts designed for the stock chain cam drive. S&S Gear Drive Cams must be used with S&S gear drive camshafts.
- S&S Camshaft Installation Kit 106-5896 is strongly recommended when installing S&S gear drive cams. The kit includes gaskets and bearings required for installation. It also includes the scavenge side oil pump oring.

CAUTION

1999-'04 stock valve springs will accommodate cam shafts with up to .510" lift. This includes S&S OES cams. 2005 and later stock valve springs can accommodate camshafts with up to .585" lift. If cams are installed that exceed the lift capacity of the stock valve springs, a set of high performance valve springs must be installed that can handle the additional lift. Stock 2005 and later springs are good to S&S lifts.

INSTALLATION

- Special Tools Required
- Sprocket locking tool H-D® #42314
- Cam chain tensioner unloader H-D® #42313
- Camshaft remover/installer H-D® #43644
- Needle bearing remover/installer H-D® #42325
- Dial indicator and flex arm

1- Remove Cam Chain Drive

NOTES:

- Installation procedure is different than in previous engines. Procedure requires use of a hydraulic press and some special tools. Installation should be done by an experienced mechanic with access to a factory service manual and all required tools.
- Tighten all fasteners to correct specifications and in order described. Always use an accurate torque wrench.

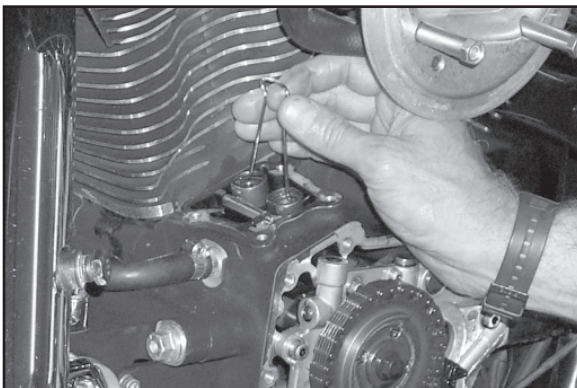

Picture 1

CAUTION

Incorrect installation can cause engine damage not covered under warranty.

WARNING

Failure to install components correctly can result in sudden engine seizure. Engine seizure may result in serious injury to motorcycle operator, passenger, or others.

- Disconnect battery ground cable to eliminate potential sparks and inadvertent engagement of starter while working on motorcycle.
- Remove spark plugs and pushrod cover clips. Collapse pushrod covers to expose pushrods.
- Safely elevate and stabilize rear of motorcycle. Place transmission in high gear. Turn rear wheel to rotate engine until both lifters and pushrods for either cylinder are at lowest point on camshaft (TDC of compression stroke). Both intake and exhaust pushrods for that cylinder will not be under pressure from the valve springs and will rotate with light finger pressure.

NOTE: S&S OES camshafts may be installed with stock style non-adjustable pushrods instead of adjustable pushrods. If installing non-adjustable pushrods, disassemble and assemble rocker box per Harley-Davidson® instructions.

- If the stock pushrods are to be reused, follow the procedure in the Harley-Davidson® service manual for pushrod removal. If stock pushrods will not be reused, they may be cut out of the engine to save time. Cut pushrods for cylinder that is at TDC with bolt cutter and remove pushrods and pushrod covers from engine. Rotate engine to place pushrods for other cylinder at their lowest point. Cut and remove remaining pushrods.

CAUTION

Cutting pushrods with a saw or cutoff wheel may result in debris entering engine, causing extensive engine damage not covered under warranty.

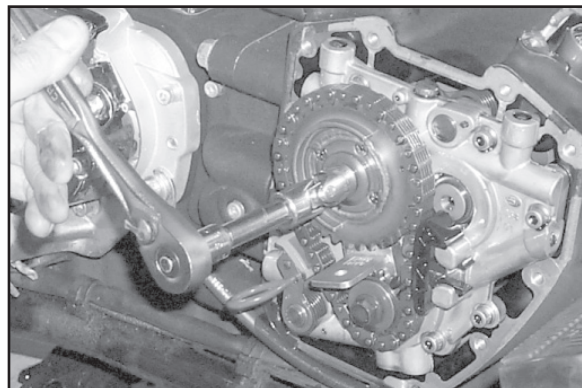

Picture 2



WARNING



Cutting pushrods when they are under spring pressure can result in pushrod parts being ejected with considerable force, and can cause bodily injury.

- E. Remove lifter covers from crankcase. Lifter covers do not have to be removed if stock non-adjustable pushrods or S&S Quickee pushrods are to be installed.
- F. Remove engine cam cover and gasket. It is not necessary to remove ignition sensor from cover. Secure lifters with a magnetic tappet tool or a tool made from a large binder clip. **See Picture 1**
- G. Remove bolts and washers from cam drive sprocket and crankshaft sprocket.

NOTE: S&S® recommends using Harley-Davidson® sprocket locking tool H-D® #42314 to secure sprockets while bolts are being removed. **See Picture 2** previous page.

- H. Use Harley-Davidson® cam chain tensioner unloader H-D® #42313 to move tensioner away from primary cam chain. Secure tensioner with retention pin. **See Picture 3** below.

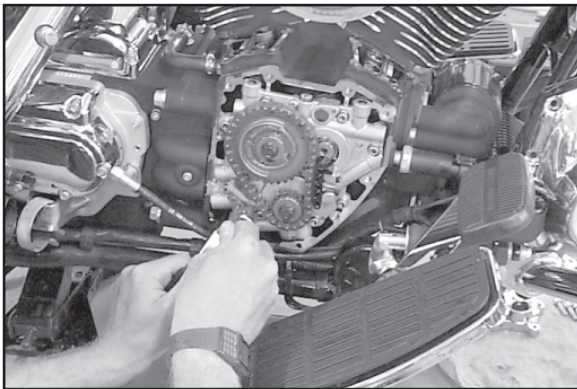

Picture 3

- I. Working gradually around edge of each sprocket, carefully pry sprockets loose. Remove sprocket and chain assembly.
- J. Remove chain guide. **See Picture 4** below.

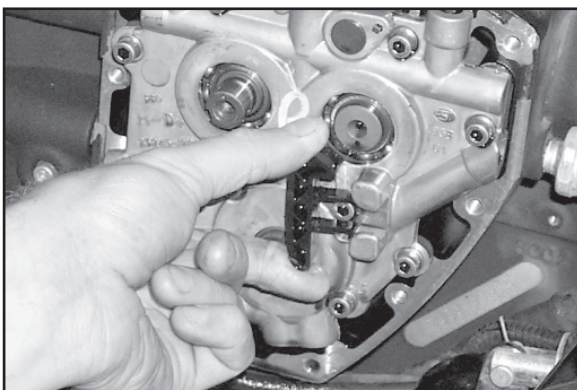

Picture 4

- K. Following sequence shown, alternately loosen and remove oil pump bolts. **See Figure 1.**
- L. Following sequence shown, alternately loosen and remove cam support plate bolts. **See Figure 2.**

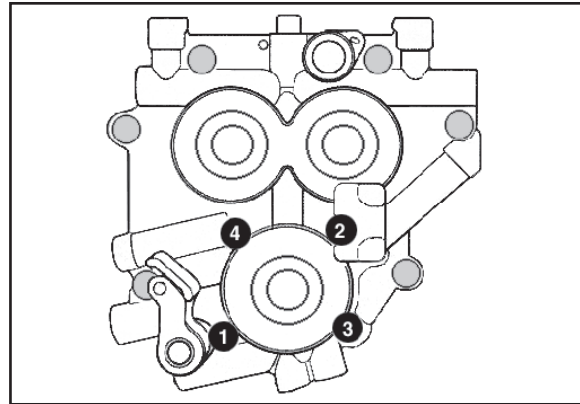

Figure 1

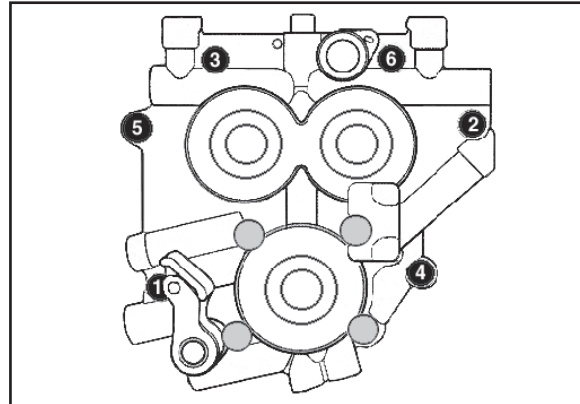

Figure 2



CAUTION



Failure to remove and install bolts according to correct procedure may result in parts damage not covered under warranty.

- M. Carefully remove cam support plate assembly from case.
- N. Check pinion shaft runout. Place an indicator on the end of pinion shaft at cam support plate bushing surface and rotate engine; reading must be .003" or less total indicated runout (TIR). If reading is greater than .003" TIR the crankshaft must be repaired or replaced to correct excess runout before installing gear drive cams.



CAUTION



Check pinion shaft runout before installing gear drive cams. Indicate end of pinion shaft at cam support plate bushing surface and rotate engine; reading must be .003" or less total indicated runout (TIR). If reading is greater than .003" TIR the crankshaft must be repaired or replaced to correct excess runout before installing gear drive cams. Failure to correct excess runout may lead to engine damage not covered under S&S warranty.

- O. Use Harley-Davidson® cam chain tensioner unloader H-D® #42313 to move tensioner away from secondary cam chain. Secure tensioner by inserting second retention pin through front of support plate.
- P. Remove bearing retainer screws and bearing retainer from cam support plate.
- Q. With cam support plate positioned securely in a hydraulic press, use Harley-Davidson® camshaft remover/installer H-D® #43644 to press both camshafts and bearings from support plate simultaneously.

NOTES:

- Cam bearings may have a loose fit in cam support plate. Camshaft and bearing assemblies may drop out when beginning pressing procedure. Camshafts with roller style bearings will be loose and drop out of support plate.
- The S&S® Gear Drive Cams require that ball bearings be used for both front and rear outer camshaft bearings to ensure consistent center to center distance between the gears. Since the gear drive does not exert a large side load on the rear camshaft, the higher load handling capacity of the stock roller style bearing is not required.

- R. Use Harley-Davidson® cam chain tensioner unloader H-D® #42313 to remove retention pin from either tensioner. Allow tensioner to completely relax. Remove retaining ring and tensioner assembly from cam support plate. Repeat this procedure for remaining tensioner.

2- Install Gear Drive Cams

NOTE: Do not reuse cam bearings. If S&S Camshaft Installation Kit 106-5896 is not being used, new bearings should be obtained from another source and installed with new camshafts. The S&S Gear Drive Cams require that ball bearings be used for both front and rear camshaft outer bearings.

- A. Carefully remove camshaft needle bearings from crankcase with Harley-Davidson® camshaft needle bearing remover/installer H-D® #42325, and replace them with new bearings provided in S&S Camshaft Installation Kit 106-5896, or with bearings from another source. Cam bearings must be Torrington B148 full complement bearing or equivalent.
- B. Apply assembly lube to outer races of cam bearings and bearing bores in support plate. With cam support plate positioned securely in a hydraulic press, use Harley-Davidson® camshaft remover/installer H-D® #43644 to install both bearings. **See Picture 5 below.**

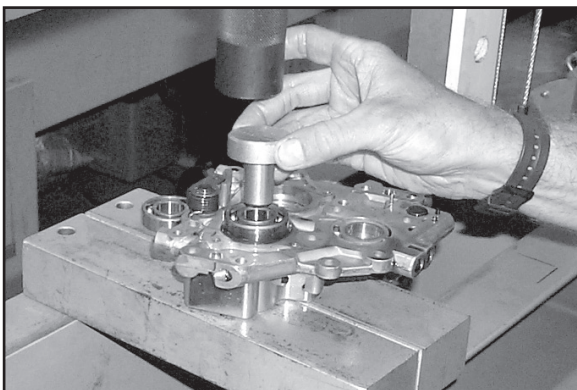

Picture 5

NOTE: Check clearance between bearing retainer and woodruff keys securing inner gears to cams. Remove material from retainer, to provide .030" clearance between key and retainer. **See Picture 6 below.**

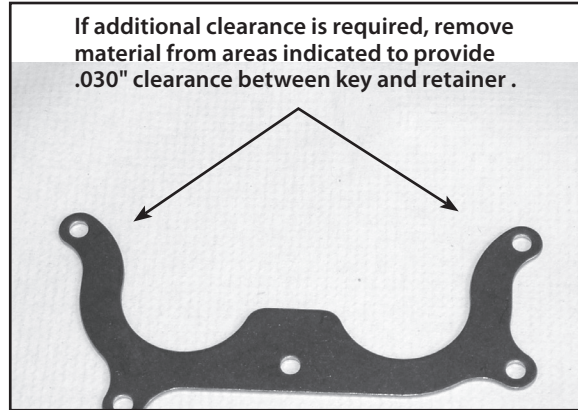

Picture 6

- C. Align hole in bearing retainer with oil passage in support plate. Install bearing retainer screws with a drop of blue Loctite® threadlock 242 or 243 and tighten screws to 20-30 in-lbs. torque. If your cam support plate is missing the oil hole between the cams don't be alarmed as some cam support plates have the hole in a new location above the rear cam, see **Picture 7, below.**

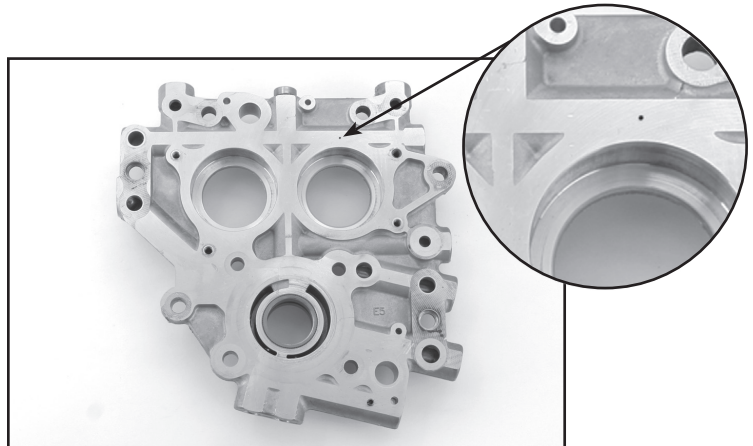

Picture 7

- D. Apply assembly lube to outer bearing surface of front (shorter) camshaft and inner race of front bearing. Support bearing by inner race and press camshaft all the way into bearing. Install retaining ring on outer end of front camshaft.

NOTE: Do not reuse retaining ring. If S&S Camshaft Installation Kit 106-5896 is not being used, a new retaining ring be obtained from another source and installed with new camshaft.

- E. Apply assembly lube to outer bearing surface of rear (longer) camshaft and inner race of rear bearing. Support bearing by inner race and with camshaft gear timing marks aligned (**See Figure 3**), press camshaft all the way into bearing.

NOTE: Before reinstalling cam support plate, replace oil pump scavenge o-ring (supplied in kit) even if the original appears to be in good condition. The stock o-ring can become brittle and provide a poor seal if reused.

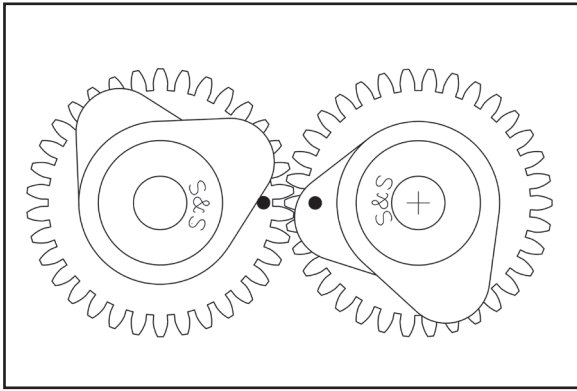

Figure 3

- F. Apply a thin layer of assembly lube to cam journals, lobe surfaces, and inner bearing surfaces. Align camshafts with needle bearings and carefully slide support plate over crankcase dowels.

NOTE: Support plate assembly should slide into place without resistance. If resistance is encountered, determine cause and correct problem before proceeding. Do not force support plate into position!

- G. Loosely install support plate screws with a drop of Loctite® threadlock 242 or 243 (blue). Alternately tighten screws to 95 in-lbs. torque following sequence shown. See Figure 2 Page 3.

CAUTION

Support plate screws that pass through alignment dowels (See positions 1 & 2 in Figure 2) can be easily stripped when applying maximum 120 in-lbs. torque as recommended by Harley-Davidson®.

- H. Install oil pump mounting bolts with a drop of Loctite® threadlock 242 or 243 (blue) according to procedure found in factory service manual: Gently bottom screws, then back them out ¼ turn. Center oil pump by rotating engine by hand while snugging down screws. Alternately tighten bolts to 95 in-lbs. torque in sequence shown. See Figure 1 Page 3. Before moving forward, verify that inner drive gears rotate freely and no binding is present.

NOTES:

- Crankshaft and cam drive gears have a light press fit on their respective shafts. Start gears squarely on their shafts and use their mounting bolts to pull them all the way into position.
- Make sure that no metal burrs are raised when installing the gear sets. Burrs can form underneath the gear causing excessive gear run out.
 1. Place drive gear key in rear camshaft. Position rear cam drive gear on rear camshaft and key with timing mark outward.

- J. Apply a drop of red Loctite® threadlock 262, 271 or 272 to threads of ¾"-24 x 1.75 Grade 8 cam drive gear bolt. Apply a drop of clean 20W-50 engine oil under bolt flange. Using thick washer provided, install cam drive gear bolt and tighten to 34 ft-lbs. torque. Cams should rotate freely with no binding.
- K. Place a dial indicator on a tooth of the rear cam drive gear so that it measures the movement of the teeth of the rear cam drive gear at as close being in line with the direction of rotation as possible. This can be done with a "finger" on the probe as shown in **Picture 8**, or by other arrangement. Dial indicator can be secured with a flex mount or by bolting it to the crankcase at the gear cover surface.
- L. Hold the front cam with finger pressure to keep it from rotating, and rock the rear cam drive gear back and forth. Record the

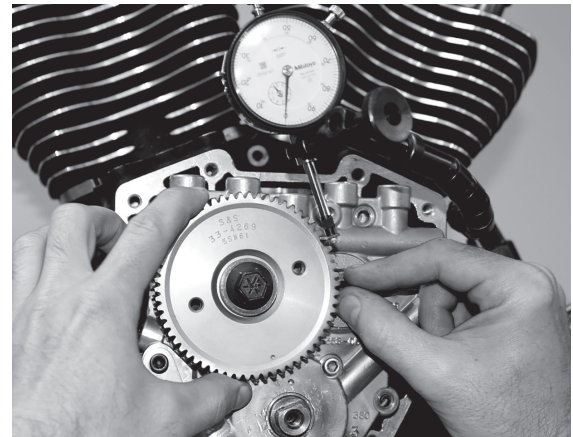

Picture 8

amount of gear tooth movement as shown on the dial indicator. Repeat this measurement in four positions at 90° intervals of cam gear rotation. Divide the readings by 2 to correct for the difference in diameters in the inner gears and the outer drive gear. The lowest of the readings after dividing by 2 should be between .0005" and .001". If backlash is not correct, inner rear cam gear must be replaced with either oversized or undersized inner gear. These gears are not included in the cam kit. See line drawing on page 8 for part numbers.

CAUTION

Too much backlash can cause excessive gear noise or clicking caused by the reversing of the forces applied by the lifters to the cam lobes. Insufficient backlash, will cause gears to whine, wear prematurely, create excess heat, and may cause breaking of the gear teeth and engine failure

NOTE: The rear cam drive gear is slightly larger than the stock drive sprocket and needs to be checked for interference with cam cover before proceeding.

- M. Place transmission in high gear and turn rear wheel to rotate engine so that when the crankshaft pinion gear is installed, the timing mark will line up with the timing mark on the rear cam drive gear. **See Figure 4.**

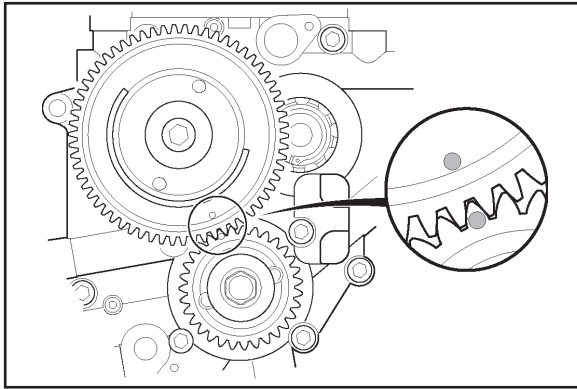

Figure 4

- N. Place pinion gear on the pinion shaft with timing mark outward. Apply a drop of red Loctite® threadlock 262, 271 or 272 to threads of $\frac{5}{16}$ "-18 x $\frac{3}{4}$ " Grade 8 crankshaft gear bolt, provided in S&S® Camshaft Installation Kit 106-5896 or obtained from another source. Apply a drop of clean 20W-50 engine oil under bolt flange. Using the washer removed in disassembly step G, install crankshaft gear bolt and tighten to 25 ft-lbs. torque.
- O. To check backlash between the rear cam outer drive gear and the crankshaft pinion gear, place the dial indicator on a tooth of the rear cam outer drive gear. Rock the rear cam outer drive gear back and forth, and record the indicated backlash. Use the rear tire to turn the engine, and check the lash in four positions at 90° intervals on the pinion gear. Since these measurements are taken directly, they are correct as indicated. Do not divide by 2. Backlash measurements for outer gears may vary depending on the total indicated run-out (TIR) of the pinion shaft. The lowest of the four measurements should be between .0005" and .001", but none should be over .002". If backlash is not correct, pinion gear must be replaced with either an oversized or undersized pinion gear. These gears are not included in the cam kit. See line drawing on page 8 for part numbers. If the lowest backlash readings are within specification and the highest reading is over .002", the pinion shaft of the flywheel assembly has too much run out and must be corrected.
- P. Press a small piece of clay or kneadable putty on cam cover mounting boss shown. **See Figure 5.** Carefully hold cover and cover gasket in position against crankcase. Install mounting bolts (4) near corners of cover finger tight. Push or tap cam cover towards front of engine.
- Q. Carefully remove cam cover. Determine cover-to-gear clearance by measuring impression left in clay by gear at its thinnest point. Clearance should be .030" or more.

If clearance is less than .030", or if cover contacts gear, remove only enough material from cam cover to obtain correct clearance. Repeat steps P and Q if necessary.



Be careful not to grind too deeply and break through to the outside of the cam cover. Damage to cam cover caused by removing too much material is not covered under warranty.

- R. Use a new gasket and install cam cover. Tighten cover bolts to 90-120 in-lbs. torque in sequence shown. **See Figure 6.**
- S. Remove clips to release lifters. If necessary, place transmission in high gear and turn rear wheel to rotate engine until both lifters of front cylinder are at lowest point on camshaft. The engine is now at TDC of compression stroke for front piston. This is the proper point to adjust the pushrods.
- T. Loosen locknuts on adjustable pushrods and turn adjusters to make all rods as short as possible.
- U. Longer S&S® pushrods are for exhaust valves, and shorter ones are for intake. Pass one long and one short pushrod through assembled pushrod covers. Place pushrod and cover assemblies through lifter cover. Inner tappet hole is for intake pushrod, and outer tappet hole is for exhaust pushrod. While holding a new gasket under lifter cover, install push rod, pushrod cover, lifter cover, and gasket as an assembly on crankcase. Tighten lifter cover screws to 95 in-lbs. torque.

5 Pushrod Installation And Adjustments

- A. S&S OES camshafts may be used with stock non-adjustable pushrods or with S&S adjustable pushrods.
- B. If using stock non-adjustable pushrods, follow the installation procedure outlined in the stock service manual.
- C. If using S&S adjustable pushrods, follow the installation and adjustment procedure in the instruction sheet provided with the pushrod kit.

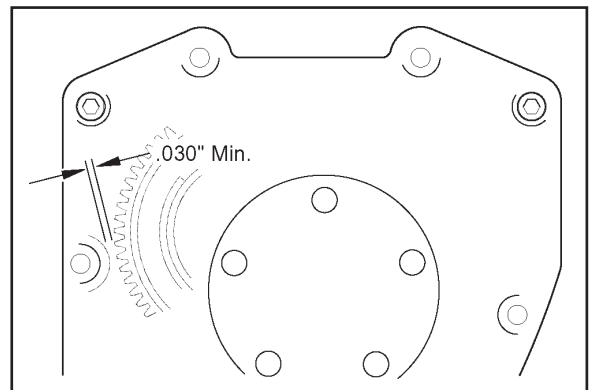

Figure 5

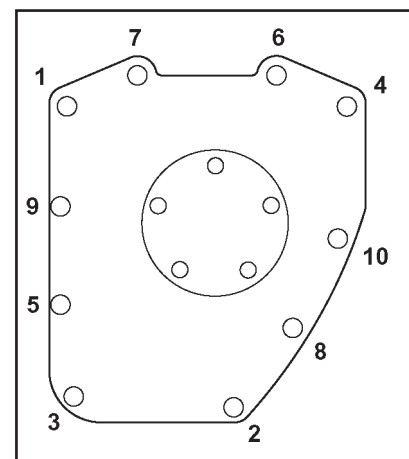

Figure 6

NOTE: If using S&S HL2T kit in tappets, adjustable pushrods are required.

S&S OES gear drive camshafts are legal for use in the State of California on 1999-2006 bikes originally equipped with "A" grind camshafts. Apply the included label containing the CARB EO # to the frame down tube above or below the factory labels. Take caution not to cover up any part of the factory label.



Picture 9

All references to Harley-Davidson® part numbers is for identification purposes only. We in no way are implying that any of S&S® Cycle's products are original equipment parts or that they are equivalent to the corresponding H-D® part number shown.

S&S® GEAR DRIVE CAMS ASSEMBLY PARTS

1- Gasket, Cam Cover.....	31-2032-S	10-Kit, Gear Drive Camshaft Installation (Includes reference #1-3, 11 & 14).....	106-5896
2- Bearing, Needle, Inner Cam (2)	31-4080	11- Screw, HHC 5/16"-18 x 3/4"	50-0100
3- Bearing, Outer Cam, Ball	31-4081	12- Screw, SHC 3/8" -24 x 1 3/4"	50-0132
4- Gear, Pinion Standard Diameter	33-4160	13- Washer, Flat 3/8"x 1 1/8"x .225"	50-7056
Undersized.....	33-4160X	14- Ring, Retaining.....	50-8061
Double Under.....	33-4160XX	15- Key, Woodruff .125 x .5 (2).....	50-8223-S
Oversized	33-4160Z	16- Key, Parallel, .188" x .150" x .420", Steel	106-1348
Double Over.....	33-4160ZZ	17- O-ring.....	50-8039
5- Gear, Cam Drive (Includes reference #12, 13 & 16)	106-4882	18-Camshaft Set Set, Camshaft, OES.....	106-4385
6- Gear, Camshaft, Front (Includes reference #15).....	33-4272F		
7- Gear, Camshaft, Rear (Includes reference #15) Standard Diameter	33-4272		
Undersized	33-4272RX		
Oversized.....	33-4272RZ		
8- Kit, Gear Drive Cams (Includes reference #4-7, 12, 13, 15 & 16)	33-4275		
9- Kit, Gear Drive Cams Outer Gears (Includes reference #4, 5, 12, 13 & 16)	33-4276		

