



Instruction 51-1197

08-09-13

© 2006, 2013

by S&S® Cycle, Inc.
All rights reserved.
Printed in the U.S.A.

S&S® Cycle, Inc.

14025 Cty Hwy G
Viola, Wisconsin 54664

Phone: 608-627-1497
Technical Service Email: sstech@sscycle.com
Website: www.sscycle.com



Installation Instructions: S&S® Performance Replacement Cylinder Head Kit for 1984-'99 Big Twin Engines

DISCLAIMER:

S&S parts are designed for high performance, closed course, racing applications and are intended for the very experienced rider only. The installation of S&S parts may void or adversely affect your factory warranty. In addition such installation and use may violate certain federal, state, and local laws, rules and ordinances as well as other laws when used on motor vehicles used on public highways, especially in states where pollution laws may apply. Always check federal, state, and local laws before modifying your motorcycle. It is the sole and exclusive responsibility of the user to determine the suitability of the product for his or her use, and the user shall assume all legal, personal injury risk and liability and all other obligations, duties, and risks associated therewith.

The words Harley®, Harley-Davidson®, H-D®, Sportster®, Evolution®, and all H-D part numbers and model designations are used in reference only. S&S Cycle is not associated with Harley-Davidson, Inc.

SAFE INSTALLATION AND OPERATION RULES:

Before installing your new S&S part it is your responsibility to read and follow the installation and maintenance procedures in these instructions and follow the basic rules below for your personal safety.

- Gasoline is extremely flammable and explosive under certain conditions and toxic when breathed. Do not smoke. Perform installation in a well ventilated area away from open flames or sparks.
- If motorcycle has been running, wait until engine and exhaust pipes have cooled down to avoid getting burned before performing any installation steps.
- Before performing any installation steps disconnect battery to eliminate potential sparks and inadvertent engagement of starter while working on electrical components.
- Read instructions thoroughly and carefully so all procedures are completely understood before performing any installation steps. Contact S&S with any questions you may have if any steps are unclear or any abnormalities occur during installation or operation of motorcycle with a S&S part on it.
- Consult an appropriate service manual for your motorcycle for correct disassembly and reassembly procedures for any parts that need to be removed to facilitate installation.
- Use good judgment when performing installation and operating motorcycle. Good judgment begins with a clear head. Don't let alcohol, drugs or fatigue impair your judgment. Start installation when you are fresh.
- Be sure all federal, state and local laws are obeyed with the installation.
- For optimum performance and safety and to minimize potential damage to carb or other components, use all mounting hardware that is provided and follow all installation instructions.
- Motorcycle exhaust fumes are toxic and poisonous and must not be breathed. Run motorcycle in a well ventilated area where fumes can dissipate.

IMPORTANT NOTICE:

Statements in this instruction sheet preceded by the following words are of special significance.



WARNING

Means there is the possibility of injury to yourself or others.



CAUTION

Means there is the possibility of damage to the part or motorcycle.

NOTE

Other information of particular importance has been placed in italic type.

S&S recommends you take special notice of these items.

WARRANTY:

All S&S parts are guaranteed to the original purchaser to be free of manufacturing defects in materials and workmanship for a period of twelve (12) months from the date of purchase. Merchandise that fails to conform to these conditions will be repaired or replaced at S&S's option if the parts are returned to us by the purchaser within the 12 month warranty period or within 10 days thereafter.

In the event warranty service is required, the original purchaser must call or write S&S immediately with the problem. Some problems can be rectified by a telephone call and need no further course of action.

A part that is suspect of being defective must not be replaced by a Dealer without prior authorization from S&S. If it is deemed necessary for S&S to make an evaluation to determine whether the part was defective, a return authorization number must be obtained from S&S. The parts must be packaged properly so as to not cause further damage and be returned prepaid to S&S with a copy of the original invoice of purchase and a detailed letter outlining the nature of the problem, how the part was used and the circumstances at the time of failure. If after an evaluation has been made by S&S and the part was found to be defective, repair, replacement or refund will be granted.

ADDITIONAL WARRANTY PROVISIONS:

- (1) S&S shall have no obligation in the event an S&S part is modified by any other person or organization.
- (2) S&S shall have no obligation if an S&S part becomes defective in whole or in part as a result of improper installation, improper maintenance, improper use, abnormal operation, or any other misuse or mistreatment of the S&S part.
- (3) S&S shall not be liable for any consequential or incidental damages resulting from the failure of an S&S part, the breach of any warranties, the failure to deliver, delay in delivery, delivery in non-conforming condition, or for any other breach of contract or duty between S&S and a customer.
- (4) S&S parts are designed exclusively for use in Harley-Davidson® and other American v-twin motorcycles. S&S shall have no warranty or liability obligation if an S&S part is used in any other application.

Introduction

S&S® Stock replacement cylinder heads are designed to increase the performance of Harley-Davidson® Evolution® big twin engines with an easy and economical cylinder head replacement.

- Compatible with stock and aftermarket flat-topped pistons - special pistons are not required.
- The exterior dimensions of these heads are similar to stock, - no clearancing is normally required when replacing stock heads on engines installed in stock chassis
- Compatible with stock components such as intake manifolds, exhaust pipes, rocker arms, and rocker covers.
- Machined to accept the stock cylinder head sensor on EFI models.
- Cams of up to .585" lift may be used as received, and higher lift S&S valve springs may be installed for up to .640" lift
- Adjustable pushrods are required

Installation Instructions

Installation of an S&S Stock replacement cylinder head kit is easy and can be performed by any Harley-Davidson repair shop equipped to do engine overhauls. No special tools other than those used in normal top end service are required.

Read instructions thoroughly before starting work. When they are completely understood proceed with installation.

1. Following procedures outlined in appropriate Harley-Davidson® service manual, prepare motorcycle for top end service.

- Disconnect battery
- Drain all gasoline from gas tanks
- Remove gas tanks and any other parts needed allow top end service.

WARNING

Gasoline is extremely flammable and explosive under certain conditions and toxic when breathed. Do not smoke. Perform installation in a well ventilated area away from open flames or sparks.

2. Disassemble top end. It is recommended that cylinders be removed and base gaskets be replaced.

Top View Driveside

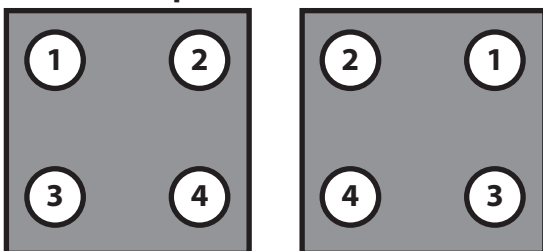

Head Bolt Torquing Sequence

Stage	S&S Crankcases	Stock Crankcases
Stage 1	8 ft-lbs	7-9 ft-lbs.
Stage 2	18 ft-lbs.	12-14 ft-lbs.
Stage 3	Turn Additional 90°	Turn Additional 90°

3. Thoroughly clean and inspect all parts that are to be reused. Any parts that show signs of wear or damage should be replaced. If the engine is in good condition the pistons and piston rings do not need to be replaced, but this is left to the technician's discretion.

NOTE: S&S® Stock replacement heads are designed to work with flat top pistons. If you intend to use them with any piston with a pop-up or dome, be sure to check for adequate clearance.

CAUTION

Insufficient clearance between piston domes and cylinder heads or piston domes and valves will cause damage to pistons, heads and/or valves. It is the engine builders responsibility to check for adequate clearance regardless of head and gasket combination.

4. Reassembly

- Clean threads of head bolts and cylinder studs. Spin each head bolt down on its respective stud to be sure threads are clean and free of contamination. If abnormal resistance is encountered, the cause must be determined and eliminated.
- If removed, reinstall cylinder head alignment dowels in cylinder. (Do not re-use any dowels that are damaged, or have flanges or an o-ring groove machined into them.)
- Ensure that the head gaskets and o-rings (if used) are correct for the application. Do not use 3½" stock bore gaskets for 3¾" big bore engines, or vice versa.

NOTES:

- Depending on the design of the gasket an o-ring may or may not be required around the oil return dowel. If the gasket is designed for an o-ring, make sure you install the correct o-ring for the application.
- There are two sizes of alignment dowel o-ring available: .070" diameter o-rings are to be used with .045" thick gaskets. .0825" diameter o-rings are to be used with .0625" thick gaskets.

CAUTION

Using thin o-rings with thick gaskets or thick o-rings with thin gaskets may cause oil leaks or possible ruptured head gaskets around line-up dowels due to incorrect o-ring compression.

- Carefully clean crankcase, head, and cylinder gasket surfaces with lacquer thinner or equivalent.
- Install base gaskets over cylinder studs on crankcase.
- Install cylinders using a ring compressor to ensure rings are not damaged during installation.

Figure 1

- g. Place head gaskets on cylinder. If required, install o-rings over cylinder head alignment dowels. Gaskets are to be installed clean and dry. Do not use gasket-sealing compounds on cylinder head gaskets.
- h. Bolt heads on cylinders. Place one or two drops of oil on threads of each head bolt just prior to final assembly to reduce friction and insure accurate torque readings.
- i. Tighten bolts in stages using crossing pattern. If using S&S or stock crankcases, follow the torque and sequence chart. **See Figure 1.** If using other aftermarket crankcases, contact the manufacturer for recommended head bolt torque specifications.

NOTE: Light coating of oil on head bolt threads minimizes friction so torque values are not distorted. Maintaining a good head gasket seal depends on it.

CAUTION

Improper torquing sequence and/or head bolt torque values may cause head gasket failure. Excessive torque values may cause studs to pull out of crankcase.

- j. For 1984-91 big twin models, install screw thread reducing inserts, part 90-4026, in aircleaner backplate mounting holes in cylinder heads. If threadserts do not have a locking compound preapplied, Loctite® or equivalent thread locking compound should be applied sparingly to threads of during installation. Threadserts with preapplied thread locking compound should be installed in desired position and left in place. Surface of insert should be just slightly below machined surface of head so backplate rests against head and not insert. **See Picture 1.** Threadsert will reduce hole from 1/2" -13 thread to 5/16" -18 threads to accept stock 1984-'91 air cleaner mounting bolts.

NOTE: Screwing threadsert in hole activates preapplied compound and locks it in position making it difficult to change after compound has set up.

CAUTION

If threadsert protrudes above machined surface of head, it may damage air cleaner backplate.

- k. For 1992-99 engines, DO NOT install the thread reducing inserts. Heads are machined with the correct 1/2" -13 air cleaner mounting bolts and vent fittings.
- l. Finish Assemble Top End
 - i. Install rocker covers and rocker arms per Harley-Davidson® service manual guidelines or instructions provided by aftermarket manufacturer.
 - ii. Replace all components removed in preparation for top end service according to Harley-Davidson service manual or instructions provided with any aftermarket products installed





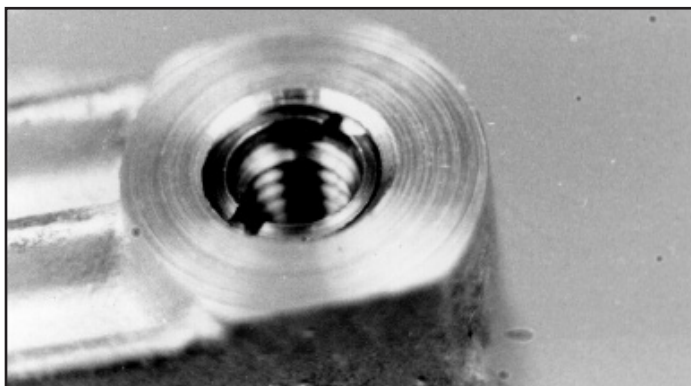

5. Initial start up and head gasket sealing







- a. Start engine and run approximately one minute at 1250-1750 rpm. DO NOT crack throttle or subject to any loads during this period as head gaskets are susceptible to failure at this time. During this time check to see that oil pressure is normal, that oil is returning to the oil tank, and that no leaks exist.
- b. Shut off engine and thoroughly check for any leaks or other problems. Let engine cool to the touch
- c. After engine has cooled, start up again and allow the motor to build some heat. Engine should be run no longer than three to four minutes. When the cylinders become warm/hot to the touch (approximately 150°) shut the motor down and let it cool to room temp. Follow the same cautions as for the initial start-up, and continue to watch for problems.
- d. Repeat this procedure 3 or 4 times. Each successive time it should take slightly longer to warm up and you can increase the temp slightly each time (+10°). You can be more liberal each time with the rpm and gently vary rpm continuously from idle up to 2500 rpm in the final cycle. The motor should not reach full operating temperature during these cycles. Do not allow engine temperature to become excessive.
- e. If new pistons or rings were installed during head installation it will be necessary to follow the normal new engine 1000-mile engine break-in process. Follow directions supplied with pistons or rings.



Picture 1

S&S® PERFORMANCE REPLACEMENT HEAD REPLACEMENT PARTS FOR 1984-'99 BIG TWIN ENGINES

1. Cylinder head Individual heads available by special order. See S&S Catalog
2. Valve
Intake – 1.900" diameter **90-2139**
Exhaust – 1.575" diameter **90-2026**
3. Valve seats
Intake – 1.900" diameter **90-2138**
Exhaust – 1.575" diameter **90-2003**
4. Valve guide – intake or exhaust
Standard Diameter .5625/.5620 (H-D® #18112-92)
 **90-2210**
+.001" Diameter .5635/.5630 (H-D® #18130-83C)  **90-2211**
+.002" Diameter .5645/.5640 (H-D® #18133-83A, 18133-83D)  **90-2212**
+.003" Diameter .5655/.5650 (H-D® #18131-83C)  **90-2213**
+.030" Diameter .5925/.5920  **90-2219**
5. Valve spring shim
.015" (each) **90-2086**
5 pack **50-7161**
.030" (each) **90-2087**
5 pack **90-2198**
6. Collar, bottom, steel **900-0414**
7. Seal, valve guide, 1999-'04 bt (H-D® #18001-83B) (each) **90-2008**
8 pack **90-2158**
8. Spring, outer **90-2050**
9. Spring, inner **90-2049**
10. Collar, top, steel (each) **90-2051-S**
11. Valve Keeper (H-D® #18229-83)(each) **90-2094-S**
8 pack **50-7166**
12. Valve spring kit, .585" lift **90-2277**
13. Head mount bolt – 3/8"–16 x 1 1/4" (H-D® #4716W)
each  **50-0168**
14. Flat washer – 3/8"
Zinc (H-D® #6019) (each)  **50-7051**
Chrome (each) **50-7106-S**
15. Head bolt assembly – Includes head bolt washer. (See S&S Catalog)
16. Head bolt washer
.100" (each) **50-7088**
5 pack **50-7096**
.250" (H-D® #6016) (each) **50-7091**
17. Exhaust port stud (H-D® #16715-83) (each) **50-0493**
5 pack **50-1028**
18. Lock washer – 5/16" **50-7032**
19. Nut, HH – 5/16" –24 (H-D® #7833, 7883) **50-5023**
20. Exhaust pipe gasket (H-D® #65324-83A, 65324-83B) (each) **106-5029**
10 pack **93-1072**
21. Thread conversion insert, 1/2"–13 to 5/16"–18 **50-8151**
22. Intake manifold (See page 3-76)
23. Screw, manifold mounting
SH 5/16"–18 x 1" (H-D® #3201WA, 2708) **50-0101**
HH – 5/16"–18 x 1" (H-D® #3987) (each) **50-0108**
24. Washer, flat – 5/16" (H-D® #6016, 6320, 70907-07) **50-7034**

25. Flange, manifold mounting
Front (H-D® #27009-86A) (each)  **16-0232**
5 pack  **16-0600**
Rear (H-D® #27010-86A) (each)  **16-0233**
5 pack  **16-0601**
Set of Two **106-3516**
26. O-ring, manifold
Stock manifolds (H-D® #26992-99, 26995-86A) (each)  **16-0236**
10 pack  **16-0244**
S&S manifolds (each) **16-0235**
10 pack **16-0243**
27. Head gasket, 1984-'99 big twin (No o-rings required)
3 1/2" Bore
.045" thick (H-D® #16770-84D, 16770-84F) (each) **93-1011-S**
10 pack **93-1024**
.0625" thick (H-D® #16664-86D, 10773-85)(each) **93-1313-S**
3 3/8" Bore
.045" thick (each) **93-1037-S**
10 pack **93-1052**
.062" thick (each) **93-1016-S**
10 pack **93-1053**
28. Alignment dowel (H-D® #16573-83, 16574-99A, 16573-83A) (each) **50-8023**
10 Pack **50-8109**
29. Temp sensor hole plug screw, SHCS, 3/8"–16 x 1" (each) **50-0161**

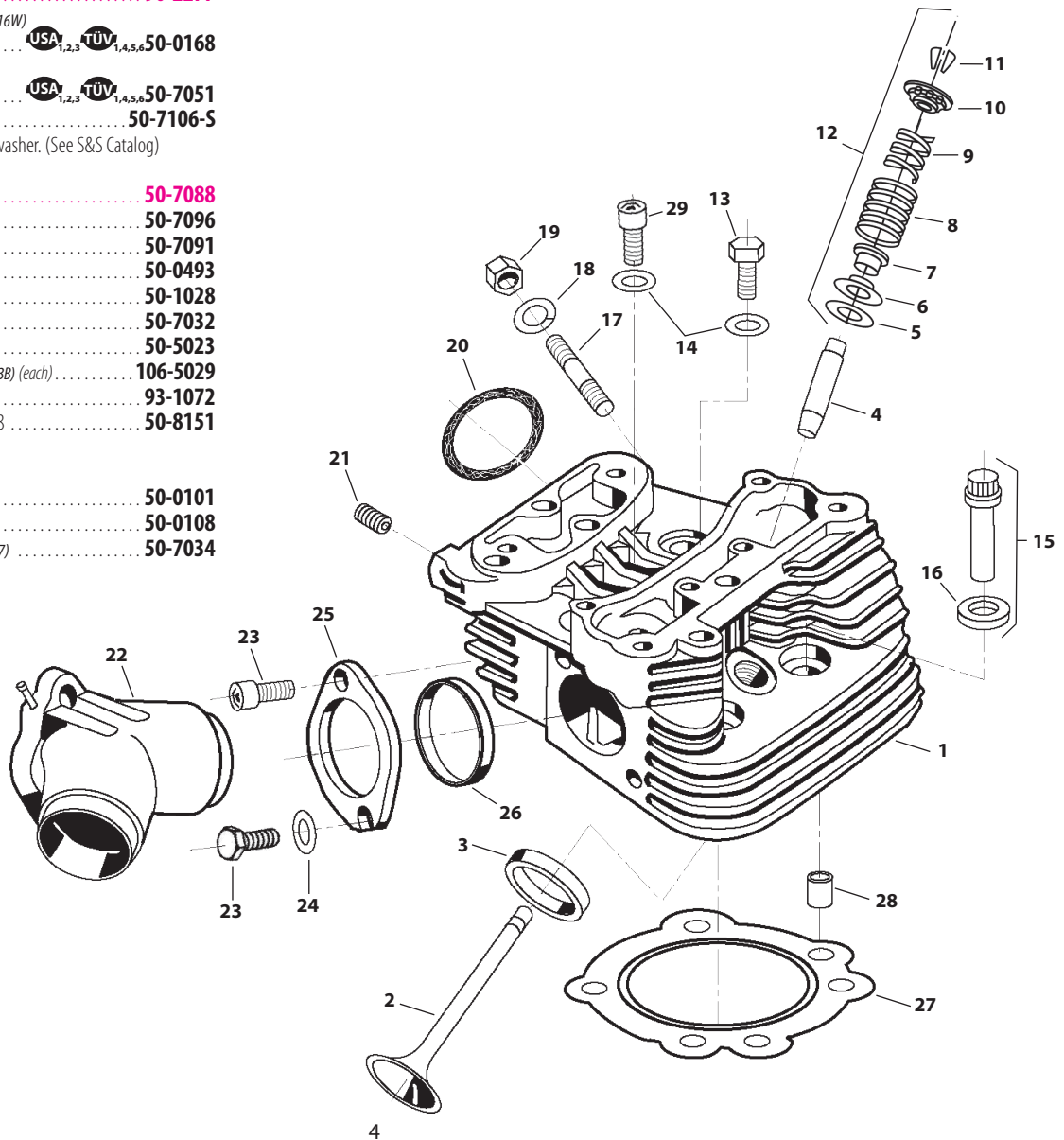

All reference to H-D® part numbers is for identification purposes only. We in no way are implying that any of S&S® Cycle's products are original equipment parts or that they are equivalent to the corresponding H-D part number shown.