



# Installation Instructions Trektop NX Twill

**Vehicle Application:**  
**Jeep Wrangler Unlimited (JK) 4 Door**  
2007 – Current  
Part Number: 56923

## Installation Tips

**Before you begin installing your new Trektop NX, please read all the instructions thoroughly.**









### For a smooth fit:

For easier installation, the top should be installed at a temperature above 72° F. Below this temperature, the fabric may contract an inch or more, making it difficult to fit the vehicle.

It is normal for the fabric to contract and wrinkle when stored in the shipping carton. Within a few days after installation, the fabric will relax and the wrinkles will disappear.



**CAUTION** Safety glasses should be worn at all times when installing this product.

Tools				Installation Time	Support
 Phillips Screwdriver	 Utility Knife	 Ratchet	 13mm Socket	 <b>2 Hours</b>	<p>We're here to help! Go to <a href="http://www.Bestop.com">www.Bestop.com</a> and click "Contact Us"</p>  <p>See a video showing installation of this top at <a href="http://www.bestop.com/video">www.bestop.com/video</a></p>
 Safety Glasses				<th>Skill Level</th>	
				<b>2 - Moderately Easy</b>	



**WARNING** This product is designed primarily to enhance the appearance of the vehicle and to shield the occupants from ordinary weather conditions. Do not rely in any way on the components of this product to contain the occupants within the vehicle, or to protect against injury or death in the event of an accident, This product will not protect the occupants from falling objects. Never operate the vehicle in excess of manufacturer's specifications.

### WEAR SEAT BELTS AT ALL TIMES

Read and follow, precisely, all installation instructions provided when installing this product. Failure to do so may result in a poor fit and could place occupants of the vehicle in a potentially dangerous situation.



## Sugerencias de Instalación

**Antes de empezar a instalar esta unidad, lea atentamente todas las instrucciones.**

**Para un buen ajuste:**

Para facilitar la instalación, el producto debe instalarse a temperaturas superiores a 72 °F (22 °C).

Por debajo de esta temperatura, la tela puede encogerse una pulgada o más, lo que dificultaría su ajuste al vehículo.

Es normal que la tela se contraiga o arrugue cuando está guardada en la caja de empaque. A los pocos días después de la instalación, la tela se relajará y las arrugas desaparecerán.



### ADVERTENCIA

Este producto se diseñó principalmente para mejorar la apariencia del vehículo y proteger a los ocupantes de las condiciones climáticas comunes. De ninguna manera piense que los componentes de este producto pueden servir como medio de contención para los ocupantes del vehículo o que pueden protegerlos contra lesiones o la muerte en caso de accidente. Este producto no protegerá a los ocupantes contra caídas de objetos. Nunca conduzca este vehículo fuera de las especificaciones del fabricante.

### USE LOS CINTURONES DE SEGURIDAD EN TODO MOMENTO

Lea y siga con precisión todas las instrucciones de instalación que se proporcionan para instalar este producto. Si no lo hace, podría producirse un mal ajuste que colocaría a los ocupantes del vehículo en una situación potencialmente peligrosa.



### PRECAUCIÓN

Debe usar gafas protectoras en todo momento durante la instalación de este producto.

## Conseils pour l'installation

**Lire toutes les instructions au complet avant de commencer l'installation de cet assemblage.**

**Pour un ajustement sans problème :**

Afin de faciliter l'installation, ce produit doit être installé à des températures au-dessus de 72 °F (22 °C).

Sous cette température, le tissu peut rétrécir d'un pouce (2,5 cm) ou plus, ce qui rendra l'ajustement sur le véhicule difficile.

Il est normal que le tissu rétrécisse et plisse pendant qu'il est dans la boîte d'expédition. En quelques jours après l'installation, le tissu se détendra et les plis disparaîtront.



### AVERTISSEMENT

Ce produit est conçu principalement pour améliorer l'apparence du véhicule et pour protéger les occupants des conditions météorologiques usuelles. Ne jamais se fier aux composants de ce produit pour se protéger de blessures ou de la mort en cas d'accident. Ce produit ne protégera pas les occupants des chutes d'objets. Ne jamais utiliser le véhicule au-delà des caractéristiques techniques indiquées par le fabricant.

### PORTER UNE CEINTURE DE SÉCURITÉ EN TOUT TEMPS

Lire et suivre, très fidèlement, toutes les instructions d'installation fournies lors de l'installation de ce produit. Ne pas suivre cette consigne peut causer une installation inadéquate et mettre les occupants du véhicule dans une situation potentiellement dangereuse.







### MISE EN GARDE

Des lunettes de sécurité doivent être portées en tout temps lors de l'installation de ce produit.

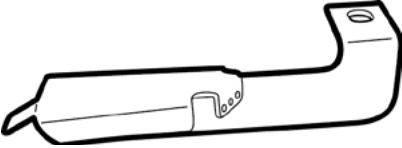
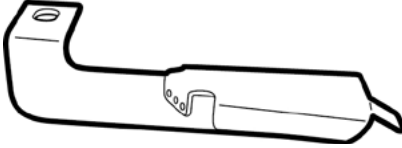

## Parts List

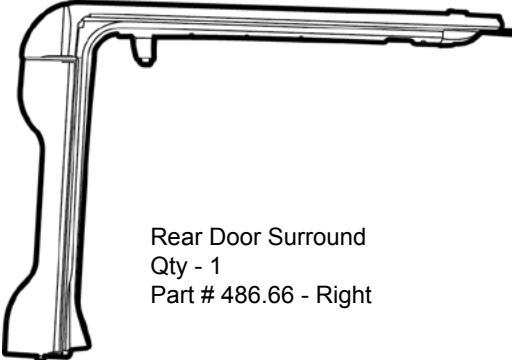

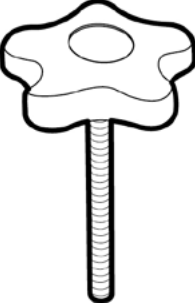



- Required parts for each installation section - Page number in Installation Guide

Sections 1 & 2		Cable Brackets & Rear Bow Brackets		Pages 6 to 9 of Guide				
								
Cable Bracket Qty - 1 Part # 502.39 - Left	Cable Bracket Qty - 1 Part # 502.38 - Right	Rear Bow Bracket Qty - 1 Part # 484.87 - Left	Rear Bow Bracket Qty - 1 Part # 484.86 - Right					
Section 3			Rear Door Surrounds			Page 10 of Guide		
								
Rear Door Surround Qty - 1 Part # 486.66 - Right	Rear Door Surround Qty - 1 Part # 486.67 - Left	M8 x 75mm Knob Qty - 2 Part # 478.90						

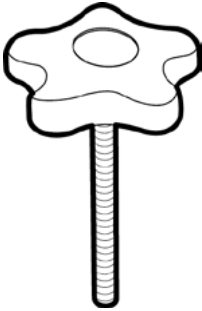
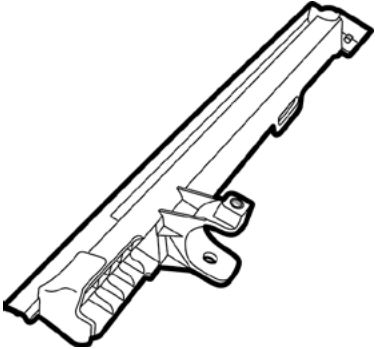
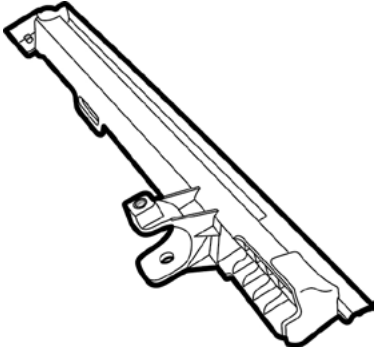

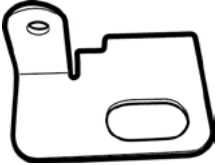
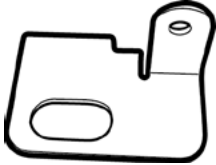
## Parts List

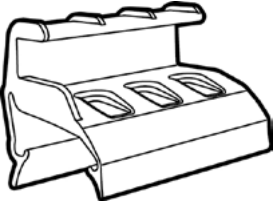
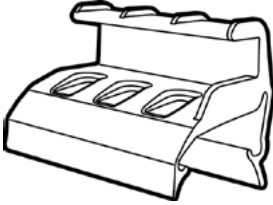
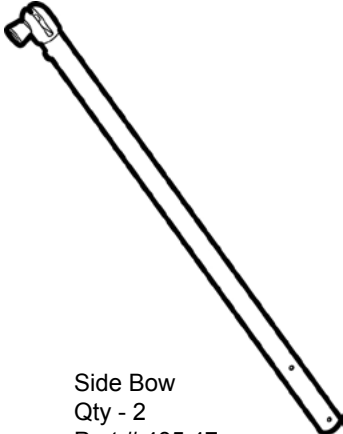
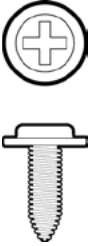

- Required parts for each installation section - Page number in Installation Guide

Sections 4 & 5		Knobs, Front Door Surrounds & Sunrider Brackets			Pages 10, 11 & 12 of Guide	
 <p>M8 x 75mm Knob Qty - 2 Part # 478.90</p>	 <p>Front Door Surround Qty - 1 Part # 479.87 - Left</p>	 <p>Front Door Surround Qty - 1 Part # 479.86 - Right</p>	 <p>M8 x 30mm Knob Qty - 2 Part # 480.22</p>	 <p>Sunrider Bracket Qty - 1 Part # 485.51 - Left</p>	 <p>Sunrider Bracket Qty - 1 Part # 485.50 - Right</p>	
Sections 6, 7, 8 & 9		Front & Rear Top Arches, Tailgate Bar Mounts & Side Bows			Pages 13 to 18 of Guide	
 <p>Front Top Arch Qty - 1 Part # 483.24</p>	 <p>Tailgate Bar Mount Qty - 1 Part # 488.47 - Left</p>	 <p>Tailgate Bar Mount Qty - 1 Part # 488.46 - Right</p>	 <p>Side Bow Qty - 2 Part # 485.47</p>	 <p>#8 x 1/2" Screw Qty - 8 Part # 393.79</p>		
 <p>Rear Top Arch Qty - 1 Part # 483.27</p>						

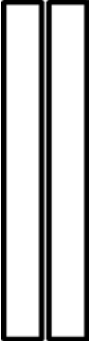
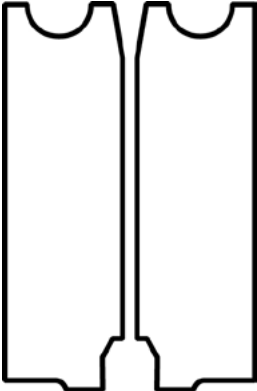
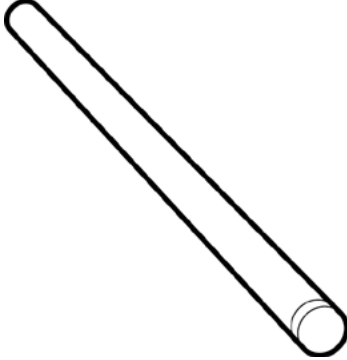

## Parts List

- Required parts for each installation section - Page number in Installation Guide

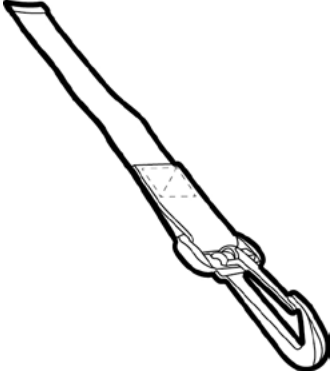
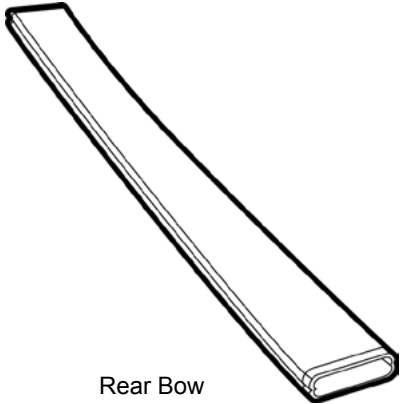
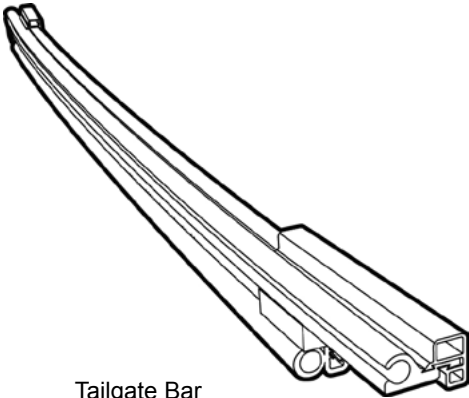
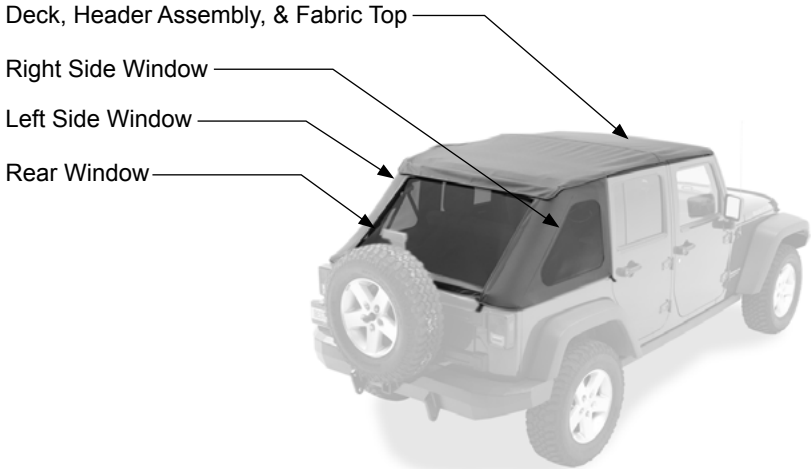
Sections 10, 12 & 13			Foam Seals, Middle Bow, Bow Clip & Web Strap		Pages 19, 21 & 22 of Guide
 <p>Foam Tape Strips Qty - 2 Part # 417.43</p>	 <p>Foam Seals Qty - 1 per side Part # 457.76 (R) &amp; 457.77 (L)</p>	 <p>Middle Bow Qty - 1 Part # 486.21</p>	 <p>Bow Clip Qty - 1, Part # 479.22</p>	 <p>Web Strap with Snap Hook Qty - 2 Part # 460.37</p>	
Sections 14 & 19			Rear Bow, Tailgate Bar, Fabric Top and Windows		Pages 16 to 31 of Guide
 <p>Rear Bow Qty - 1 Part # 486.18</p>	 <p>Tailgate Bar Qty - 1 Part # 489.46</p>	 <p>Deck, Header Assembly, &amp; Fabric Top</p> <p>Right Side Window</p> <p>Left Side Window</p> <p>Rear Window</p>			

Step 1 502.38

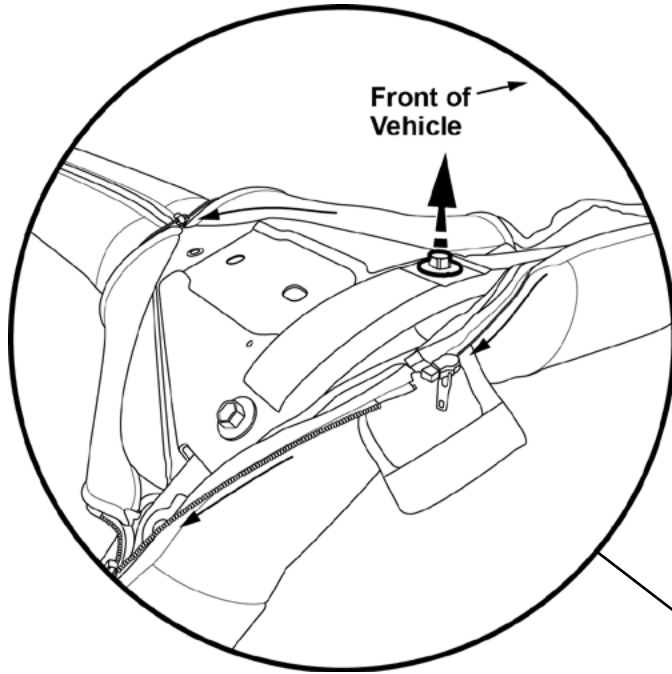

Step 2

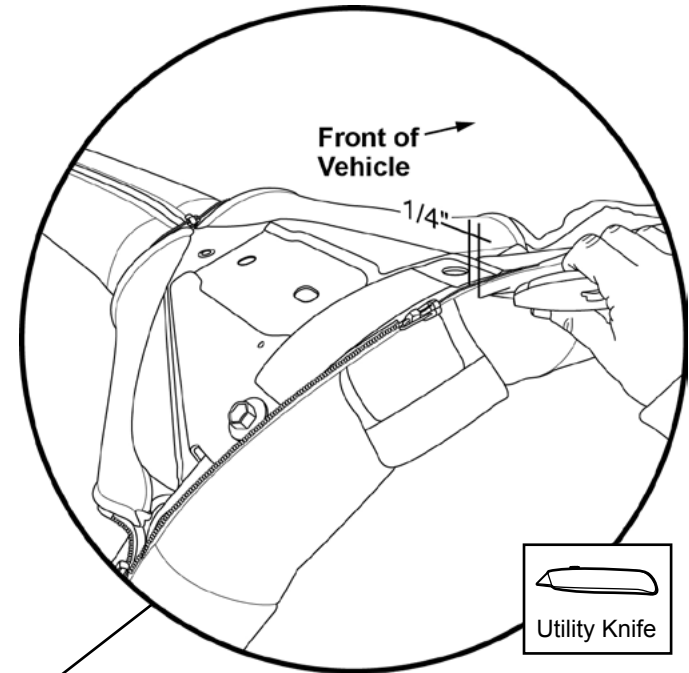

Step 1

Unzip the upper rear and rear leg sport bar covers and locate the upper sport bar bolt. Use a 13mm socket and ratchet to remove the bolt and set it aside to be reused.

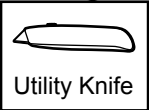

Step 2

Cut a horizontal slit the same width as the Cable Bracket in the sport bar cover 1/4\"/>A circular inset diagram showing a close-up of the sport bar cover. A hand is using a utility knife to cut a horizontal slit in the cover. The slit is labeled "1/4\"/>  

Utility Knife

**Step 3** 502.38

**Hardware**

Cable Bracket Qty - 1  
# 502.39 - Left

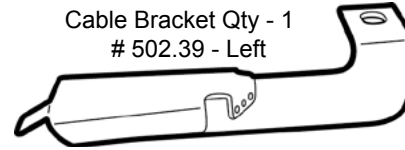

Cable Bracket Qty - 1  
Part # 502.38 - Right

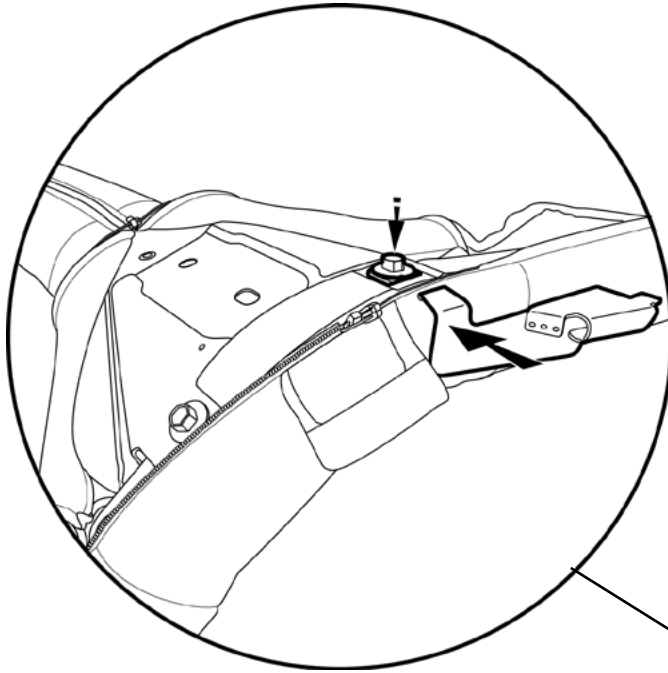
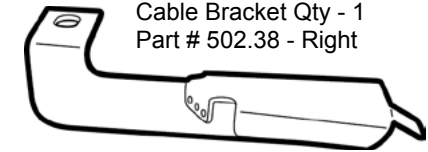

**Step 3**

Use the bolt that was removed to mount the Cable Bracket to the sport bar through the sport bar cover.

Repeat on both sides of the vehicle.



**Step 1** 484.86

**Hardware**

**Step 2**

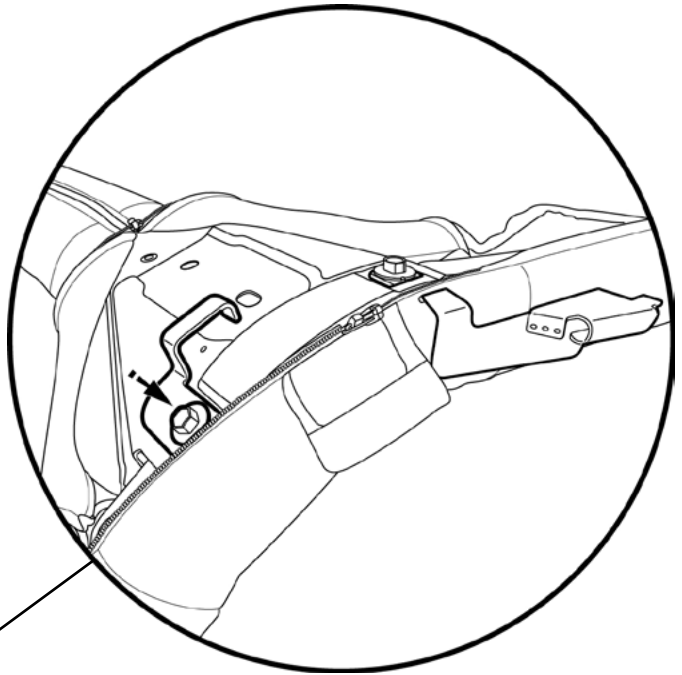
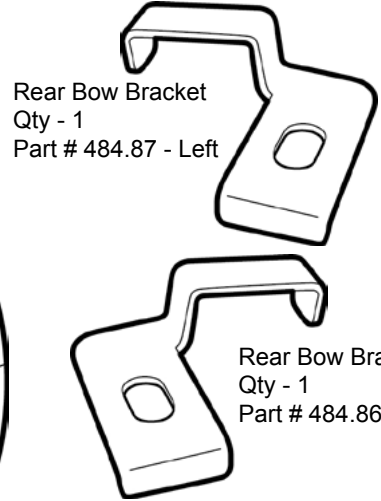
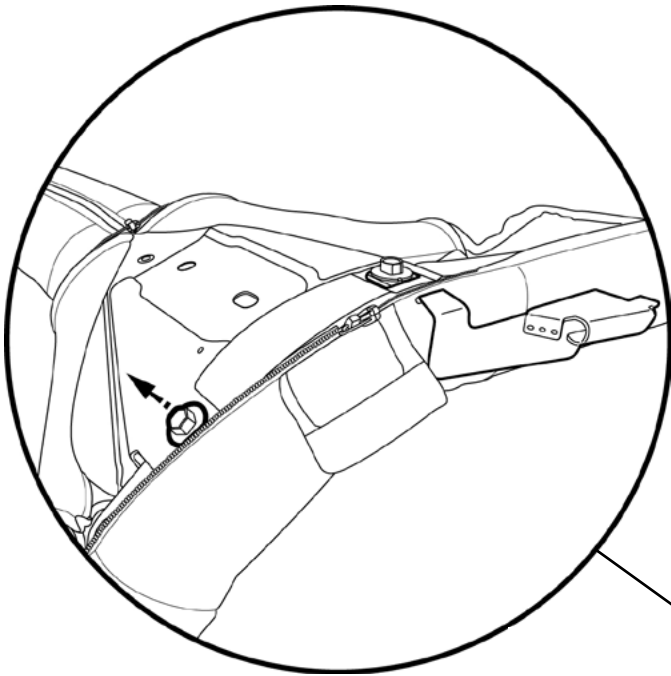

**Step 1**

Locate the rear sport bar bolt. Use a 13mm socket and ratchet to remove the bolt and set it aside to be reused.

**Step 2**

Loosely install the Rear Bow Bracket with the sport bar bolt. Mark where the bracket contacts the sport bar cover and remove the bracket.





**Step 3** 484.86

**Step 4**

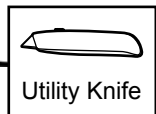
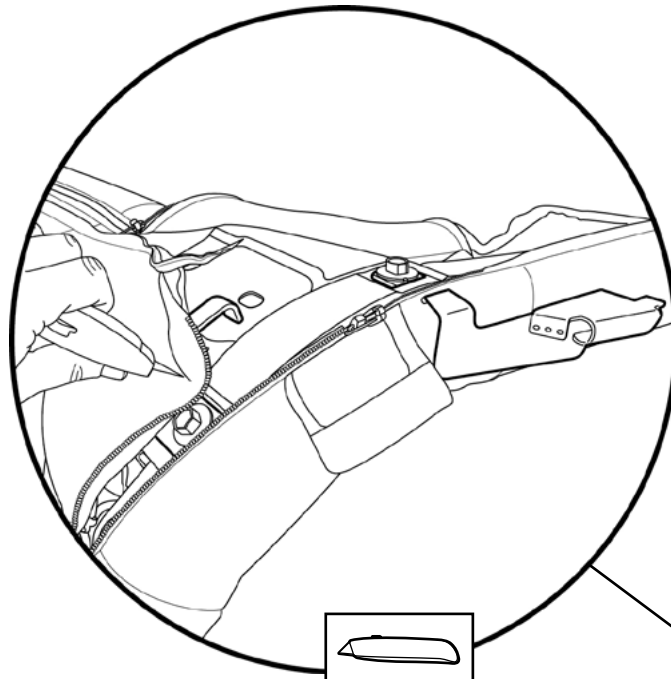

**Step 3**

Cut a horizontal slit the same width as the Rear Bow Bracket at this point.  
Reinstall the Rear Bow Bracket through the cover and tighten the bolt.

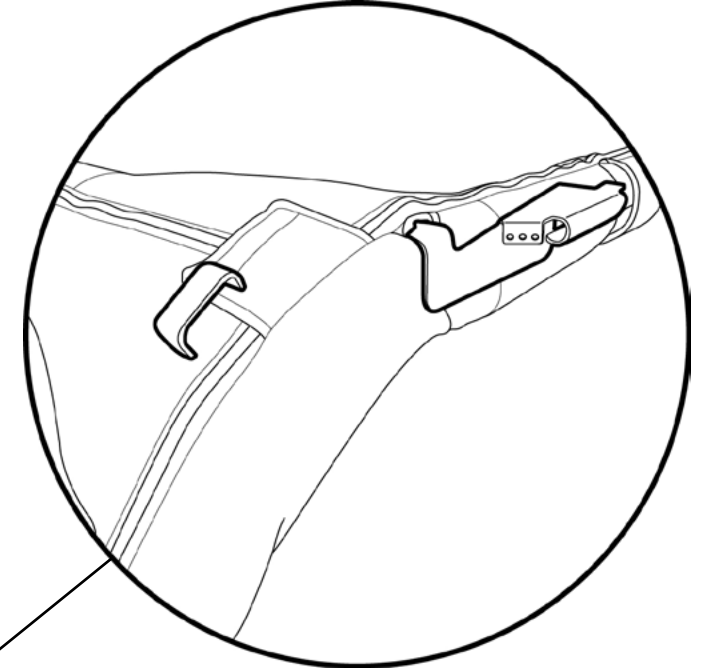

**Step 4**

Zip all sport bar covers.  
Repeat on both sides of the vehicle.



<b>Step 1</b>	486.66	478.90
---------------	--------	--------

**Hardware**

**Step 2**

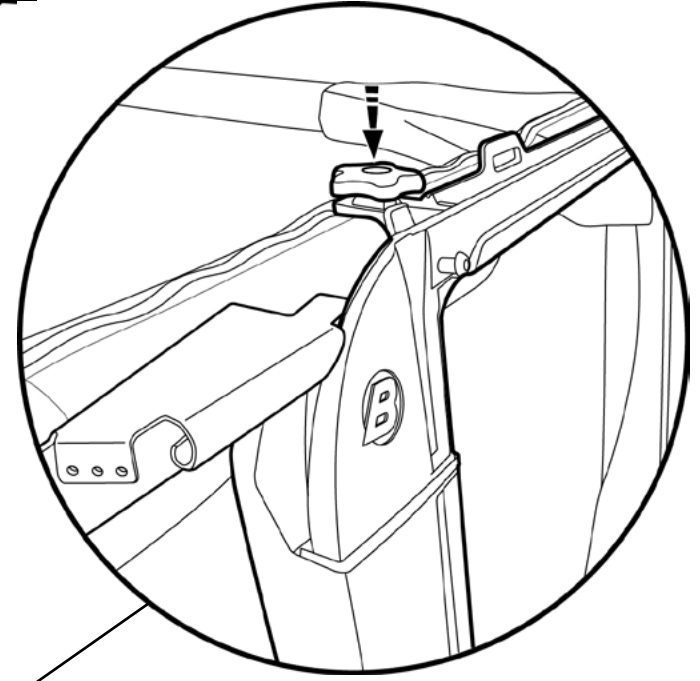
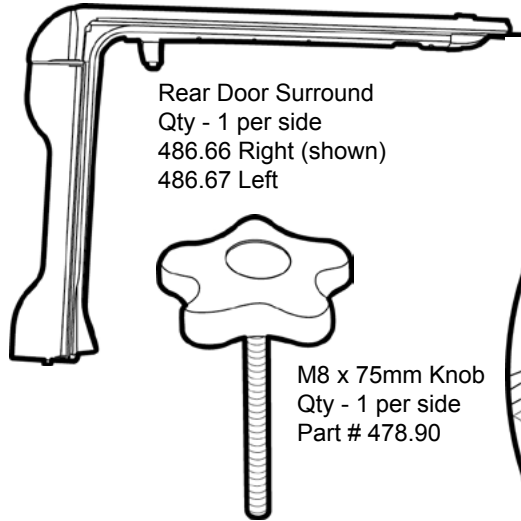
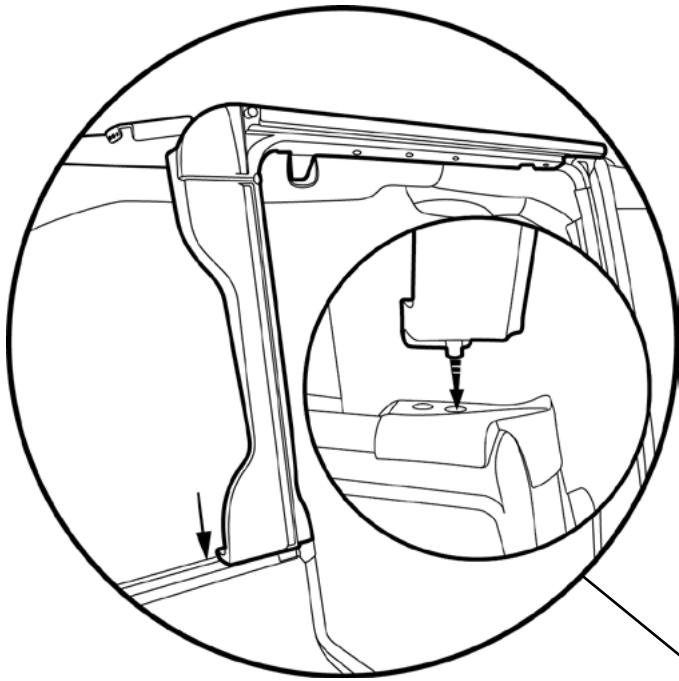

**Step 1**

Insert the pin in the bottom of the Rear Door Surround into the hole in the belt rail behind the rear door opening. Press the channel along the top of the Rear Door Surround around the horizontal sport bar. Insert an M8 x 75mm Knob into the rear position on the Door Surround.

Repeat on the other side of the vehicle.

**Step 2**

Insert an M8 x 75mm Knob into the rear position on the Door Surround. Repeat on the other side of the vehicle.

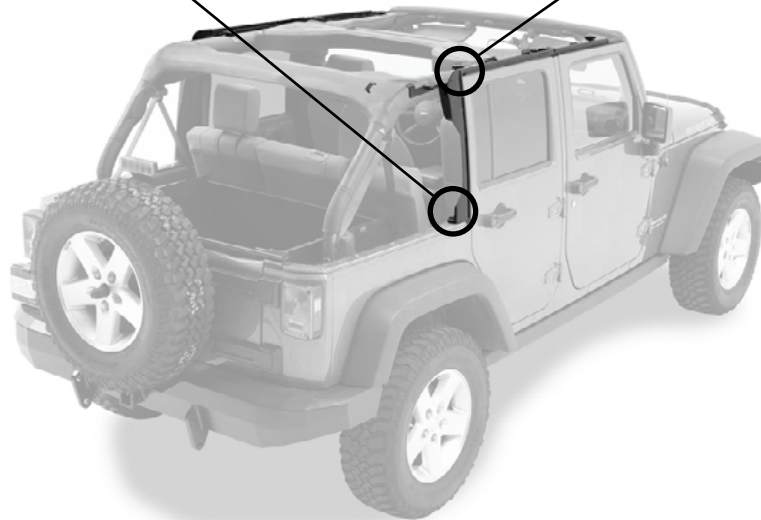

<b>Step 1</b>	479.86	478.90
---------------	--------	--------

**Hardware**



Front Door Surround  
Qty - 1 per side  
479.86 Right (shown)  
479.87 Left

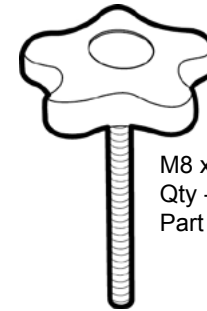

M8 x 75mm Knob  
Qty - 1 per side  
Part # 478.90

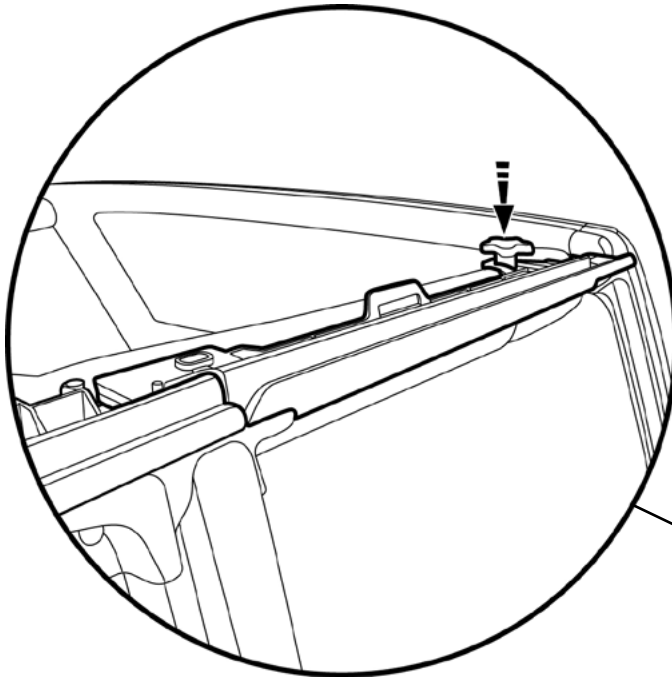

**Step 1**

Position the Front Door Surround on the sport bar above the driver's door and press it into place as with the rear.

**Step 2**

Insert an M8 x 75mm Knob into the rear position on the Door Surround.  
Repeat on the other side of the vehicle.



**Step 1** 485.50 480.22

**Hardware**

**Step 2**

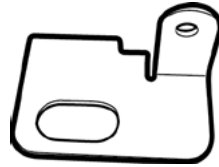

Sunrider Bracket  
Qty - 1 per side  
485.50 Right (shown)  
485.51 Left

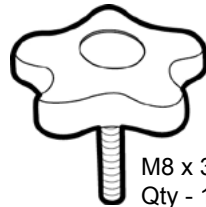

M8 x 30mm Knob  
Qty - 1 per side  
Part # 480.22

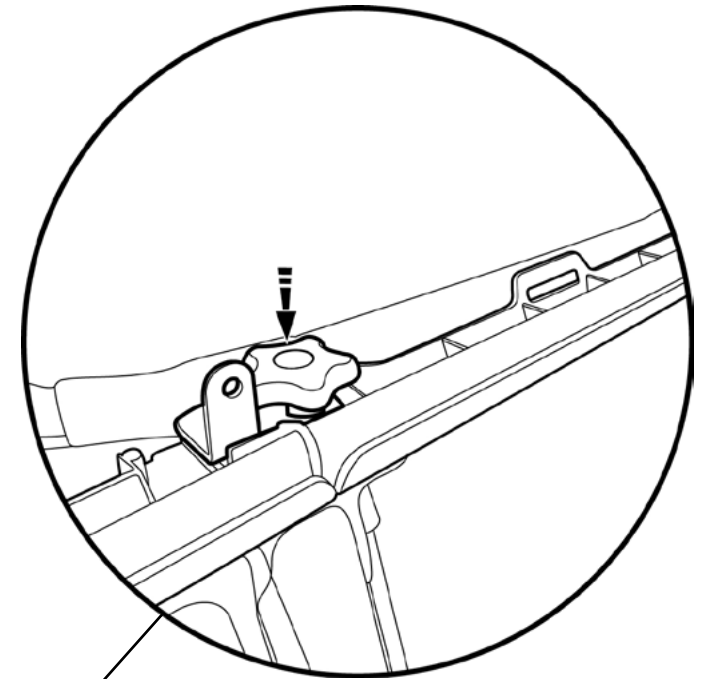
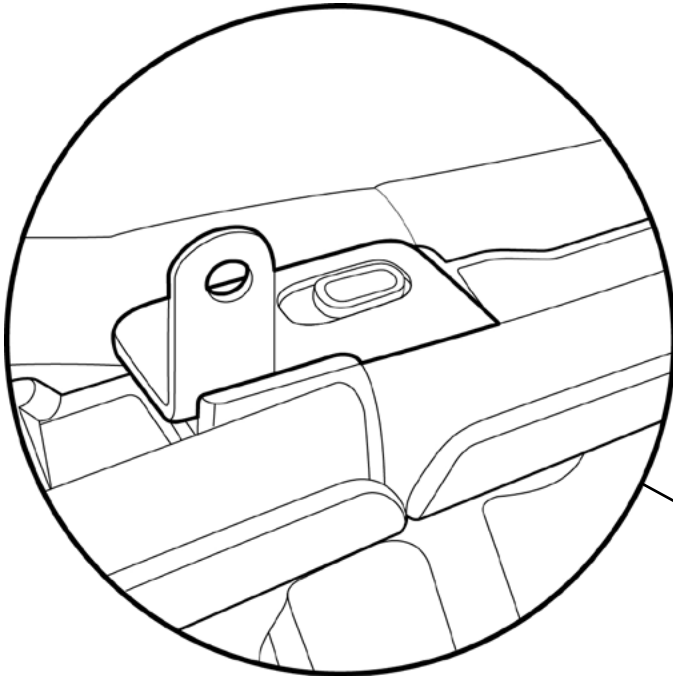

**Step 1**

Place the Left Sunrider Bracket over the hole where the Front and Rear Door Surrounds join.

**Step 2**

Secure it with the M8 x 30mm Knob. Repeat with the Right Sunrider Bracket. Repeat on both sides.



**Step 1** 483.24

**Hardware**

**Step 2**



Front Top Arch  
Qty - 1  
Part # 483.24

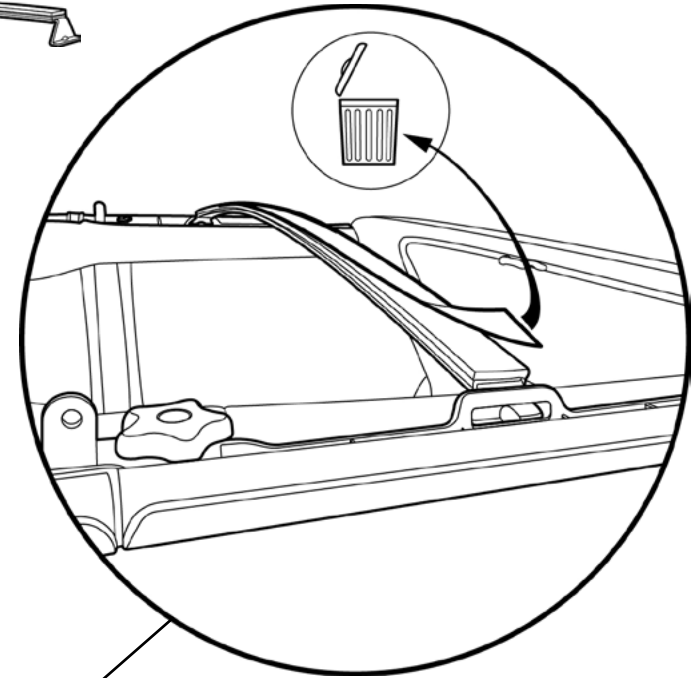
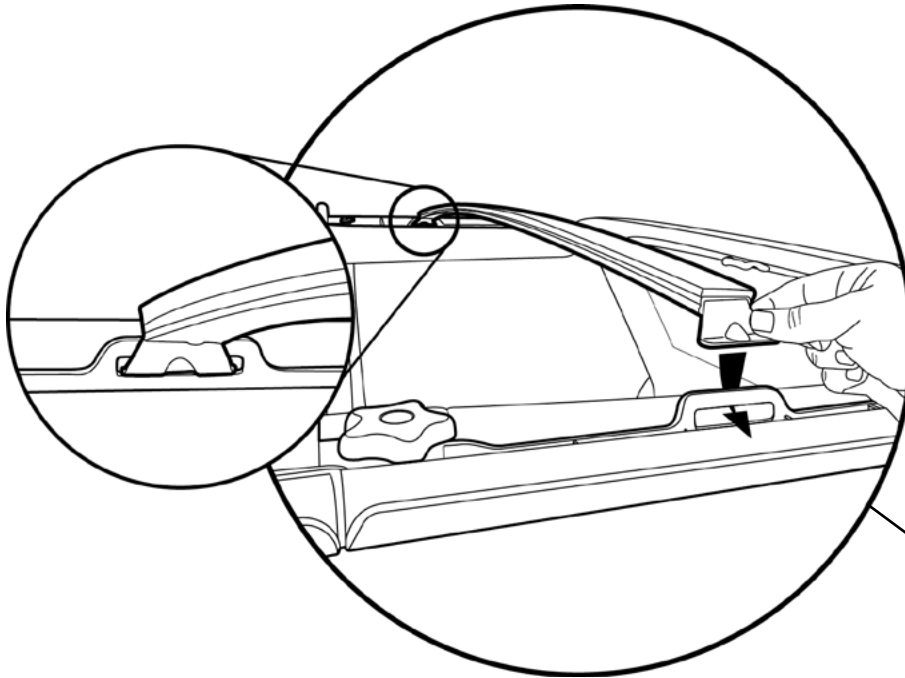

**Step 1**

Insert one end of the Front Top Arch in to the slot in the middle of one of the Front Door Surrounds. Push the other end inward to flex the bow and insert it into the slot on the other side of the vehicle.

**Step 2**

Remove and dispose of paper film.



**Step 1** 483.27

**Hardware**

**Step 2**



Rear Top Arch  
Qty - 1  
Part # 483.27

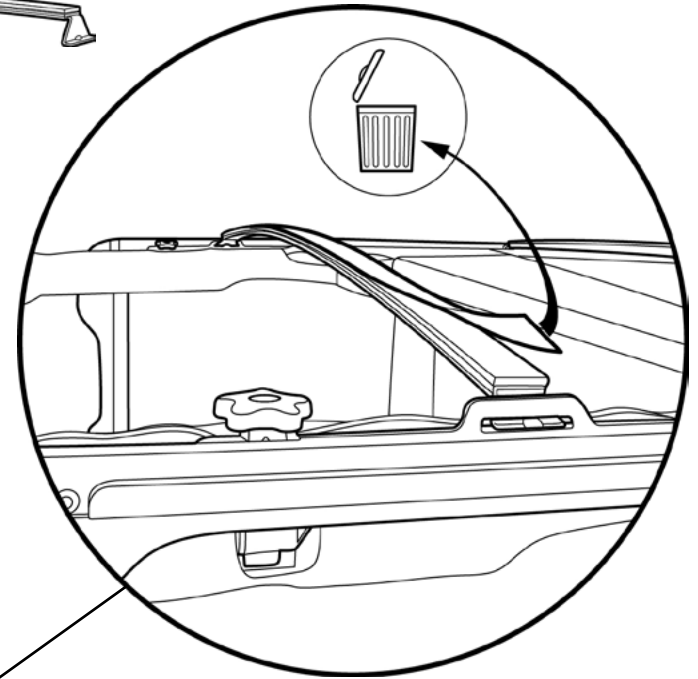
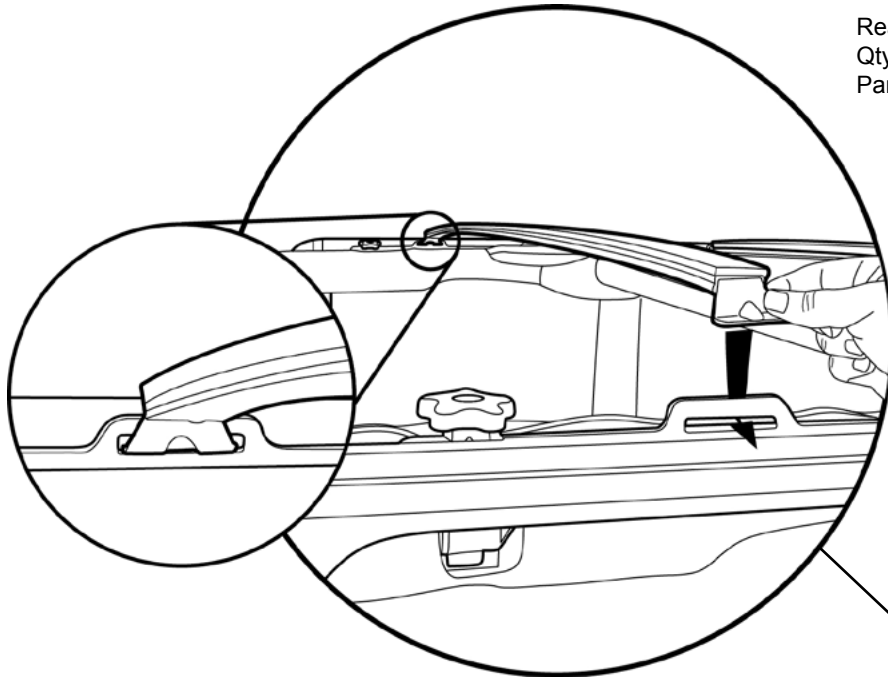

**Step 1**

Insert one end of the Rear Top Arch in to the slot in the middle of one of the Rear Door Surrounds. Push the other end inward to flex the bow and insert it into the slot on the other side of the vehicle.

**Step 2**

Remove and dispose of paper film.



**Step 1**    488.46

**Hardware**

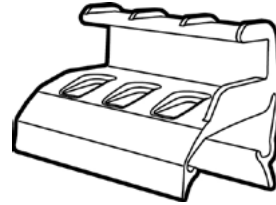

Tailgate Bar Mount  
Qty - 1 per side  
488.46 Right (shown)  
488.47 Left

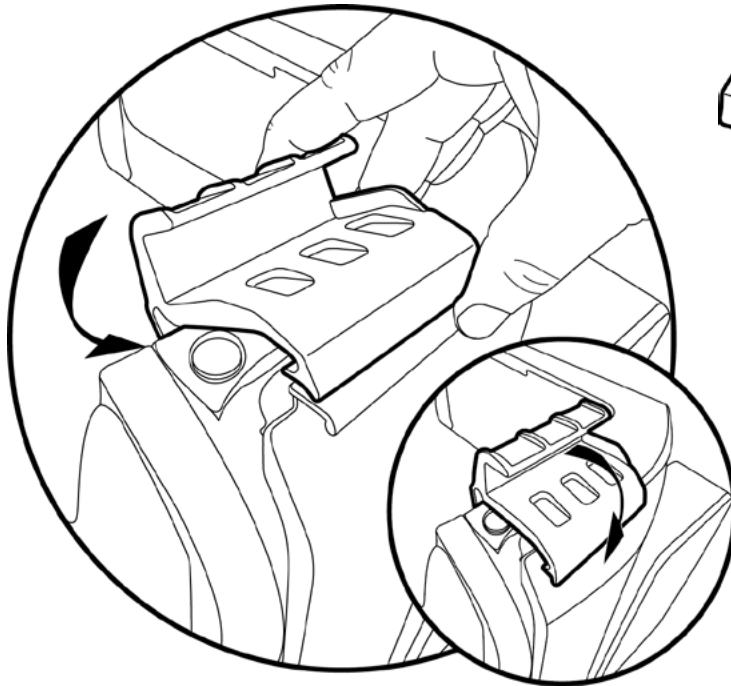

**Step 1**

Orient the Tailgate Bar Mounts on the vehicle. Hook the bottom of one mount under the ledge and roll the mount toward the outside of the vehicle until it clips into place under the belt rail. Repeat this with both Tailgate Bar Mounts.



**Step 1** 485.47

**Hardware**

**Step 2**

Side Bow  
Qty - 1 per side  
Part # 485.47

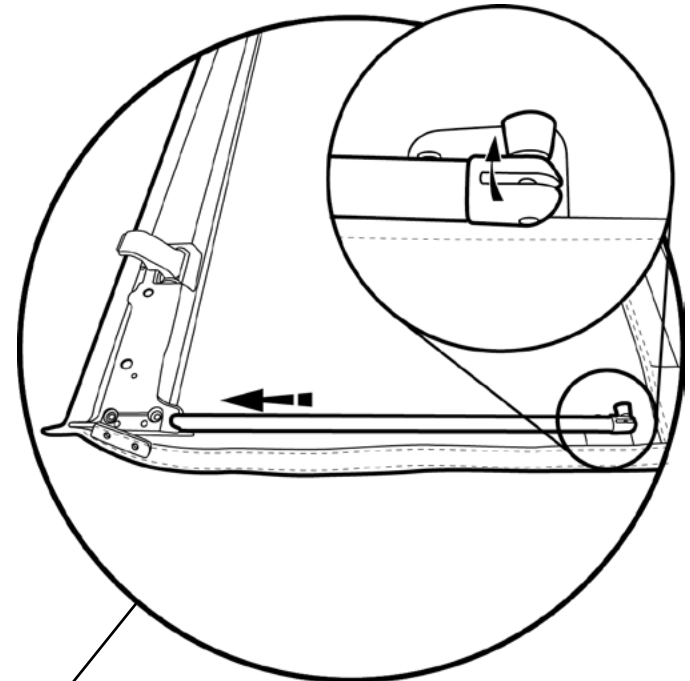
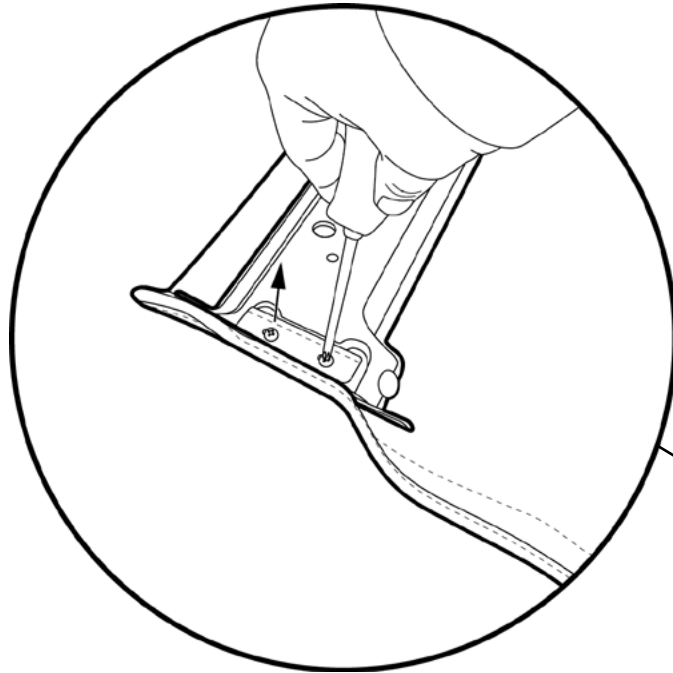

**Step 1**

Remove the screws in the Header Assembly and set aside to be reused.

**Step 2**

Insert Side Bows into Header Assembly on each side.  
Pivot quick release knobs to face toward inside of assembly.

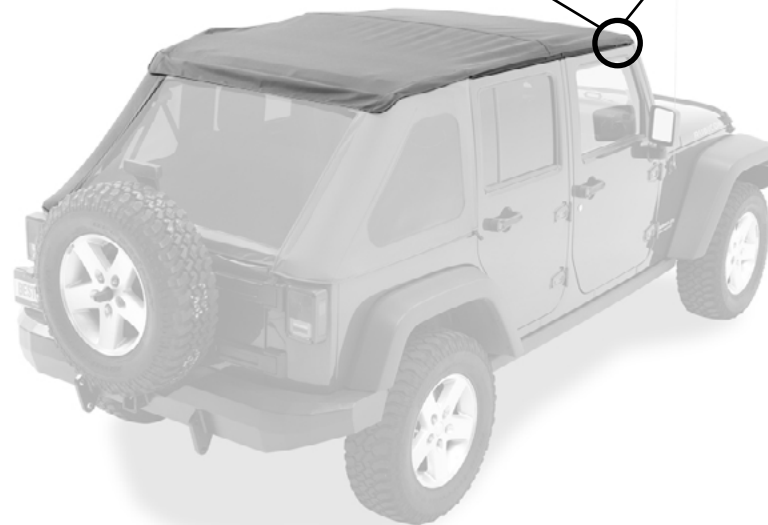



**Step 3** 485.47 393.79

**Hardware**



#8 x 1/2" Screw  
Qty - 4 per side  
Part # 393.79

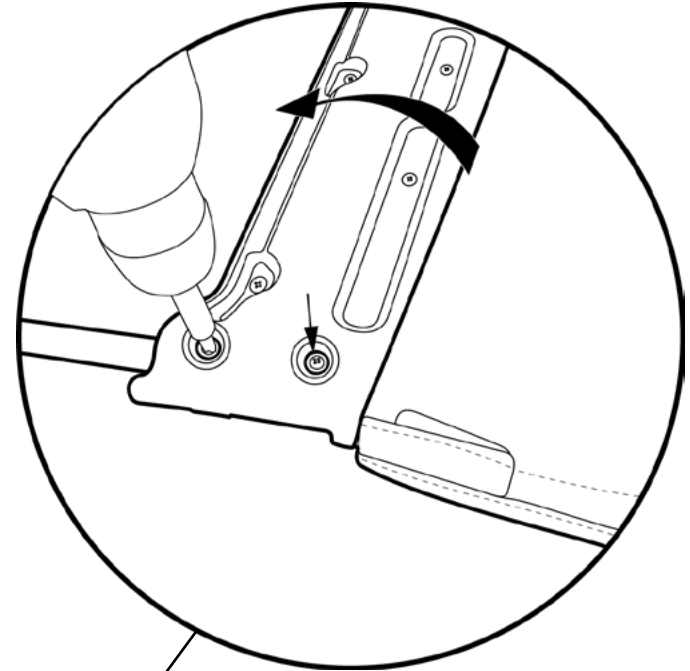
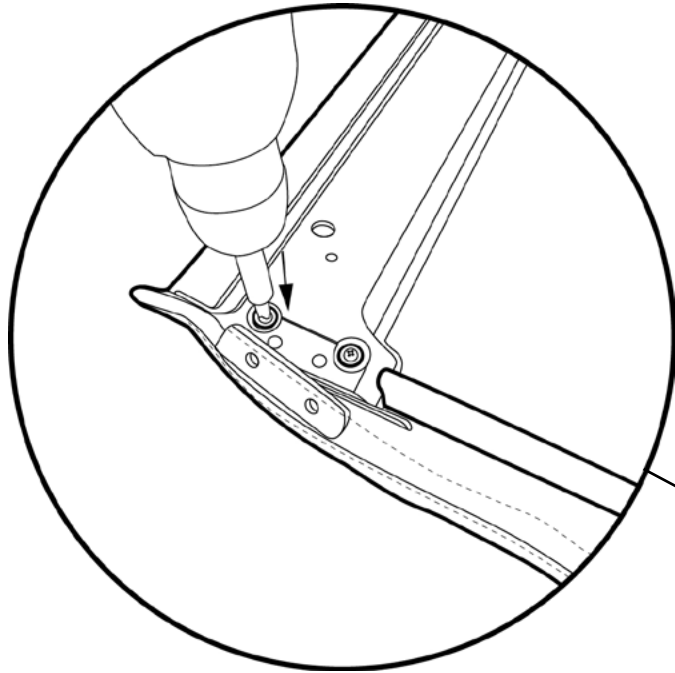
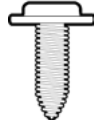

**Step 3**

Use #8 x 1/2" Screws to mount a Side Bow to each side of the Header Assembly.

**Step 4**

Rotate the Header Assembly and insert #8 x 1/2" Screws on each side.

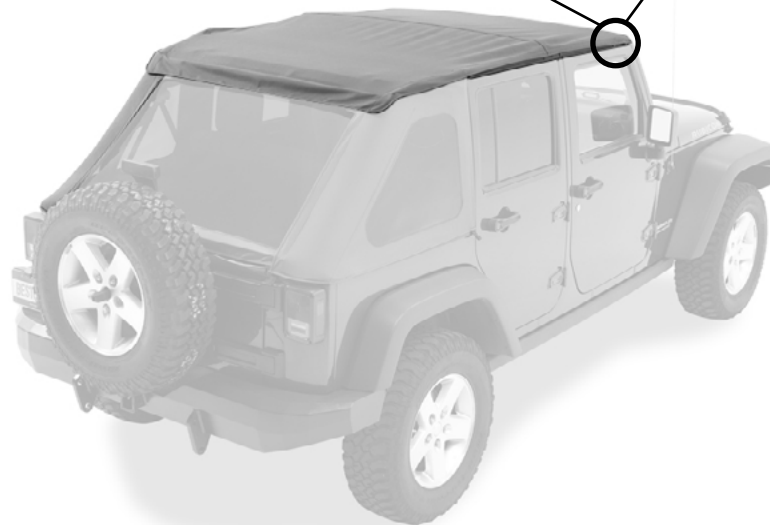

**Step 5**

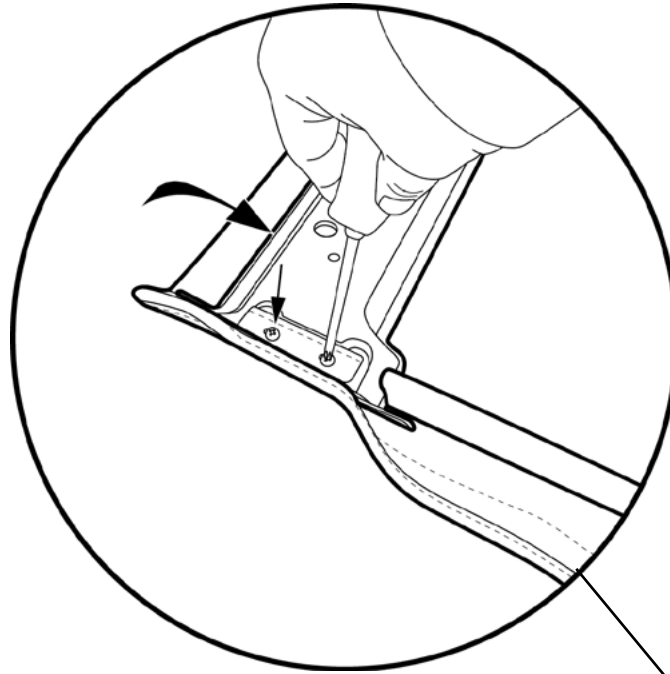

**Step 5**

Rotate the Header Assembly back into position and reinstall the screws removed in Step 1.

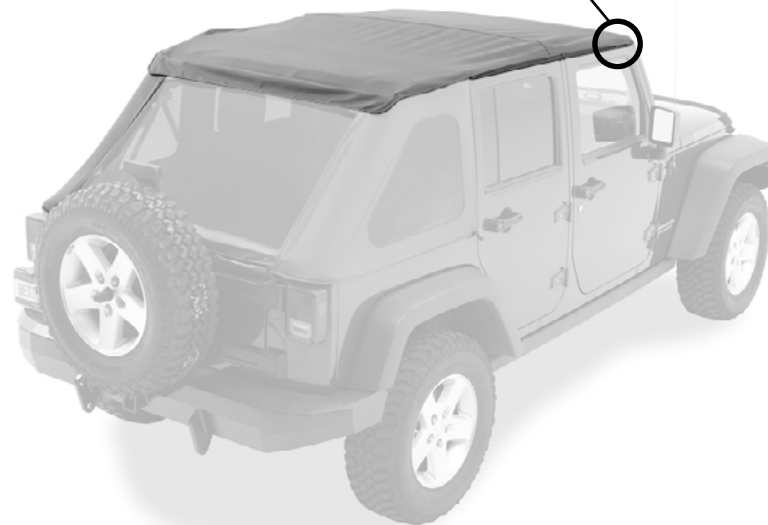

**Step 1** 417.43 457.76

**Hardware**

**Step 2**

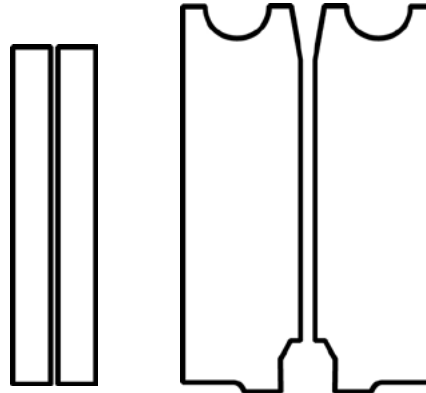
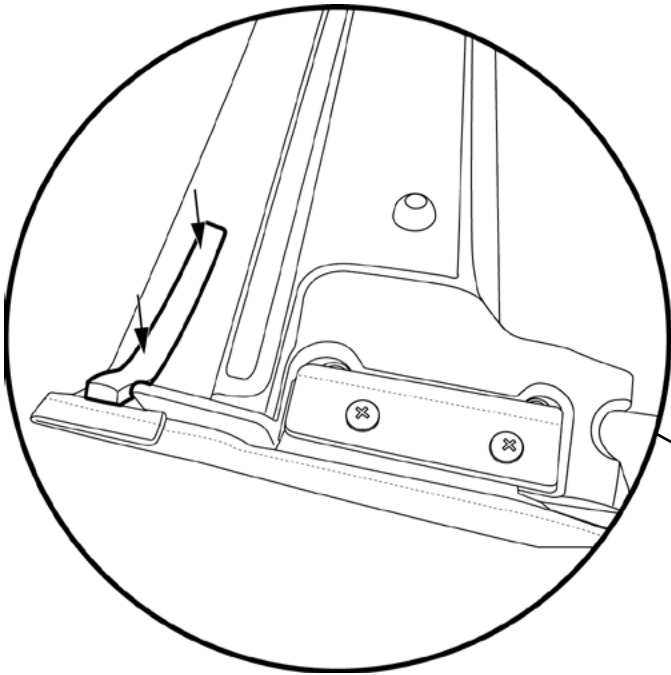

Foam Tape Strips  
Qty - 1 per side  
Part # 417.43

Foam Seals  
Qty - 1 per side  
457.76 (R) shown  
457.77 (L)

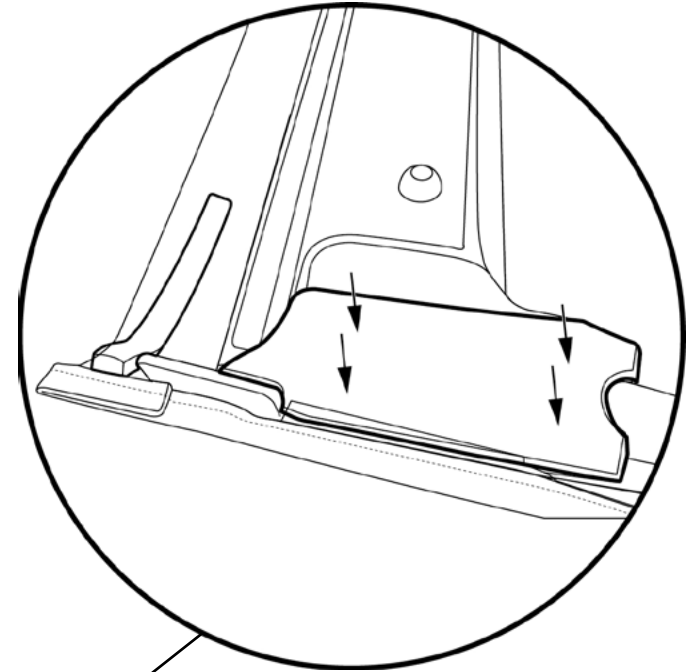

**Step 1**

Peel the backing off the Foam Tape Strips and install them on each side of the Header.

**Step 2**

Peel the backing off the Foam Seal; and install it on the passenger side of the Header. Repeat on the driver side.

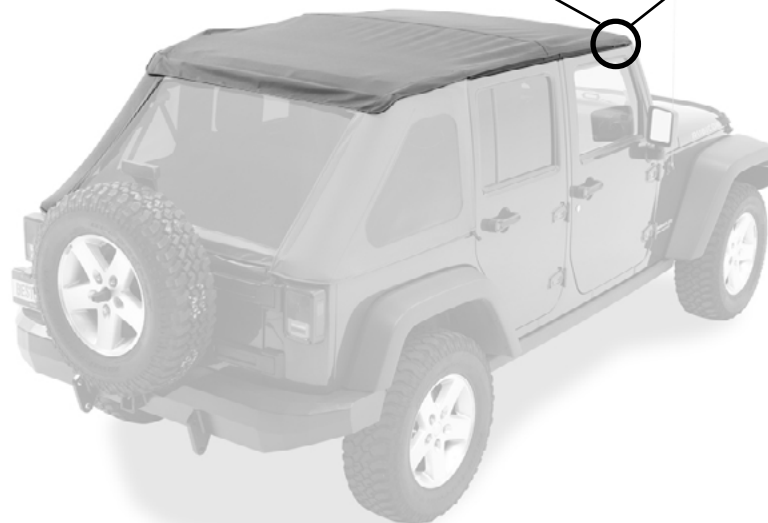

**Step 1**

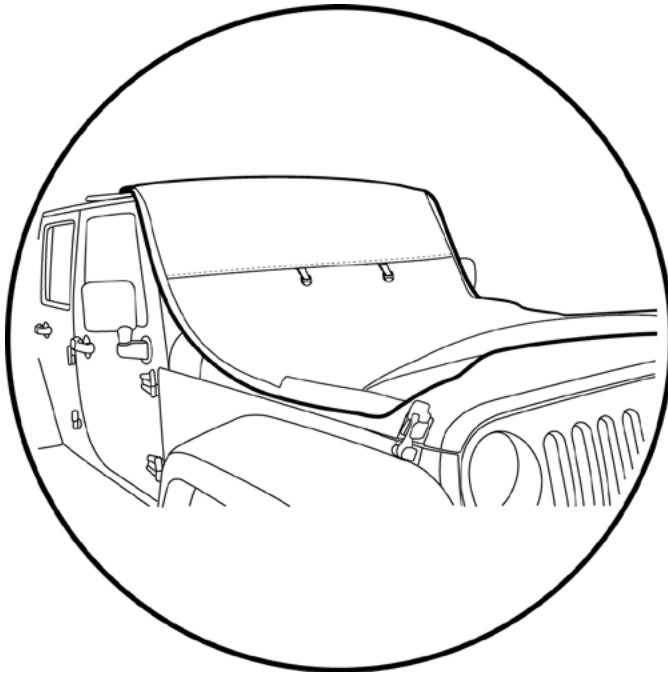

**Step 1**

Fold the Top Fabric toward the front of the Header. Place the Header Assembly on vehicle, with the backing up and the Side Bows on top of the Door Surrounds.

**Step 2**

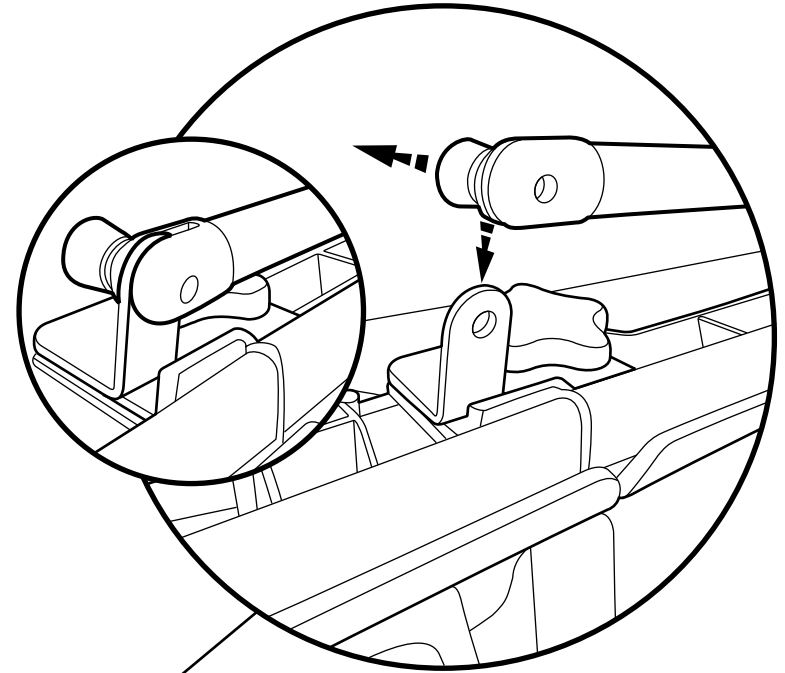

**Step 2**

Pull back on the quick release knob on the Side Bow and slide the Side Bow over the Sunrider Bracket. Repeat on the other side of the vehicle.

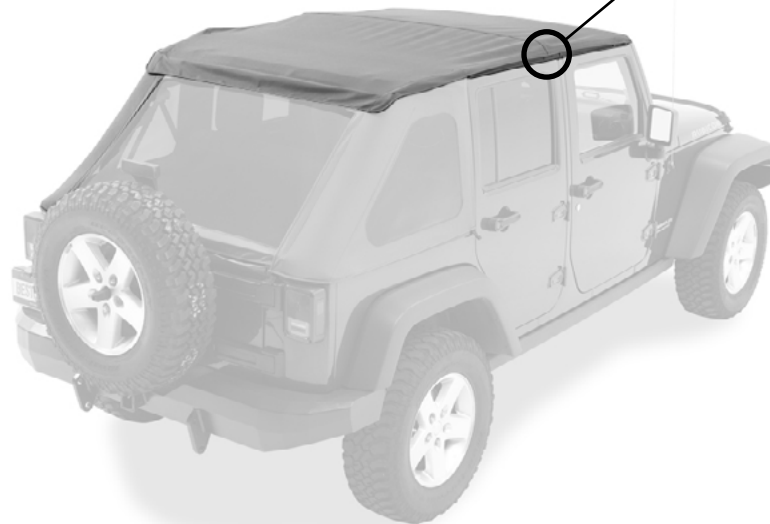

**Step 1** 486.21 479.22

**Hardware**

**Step 2**

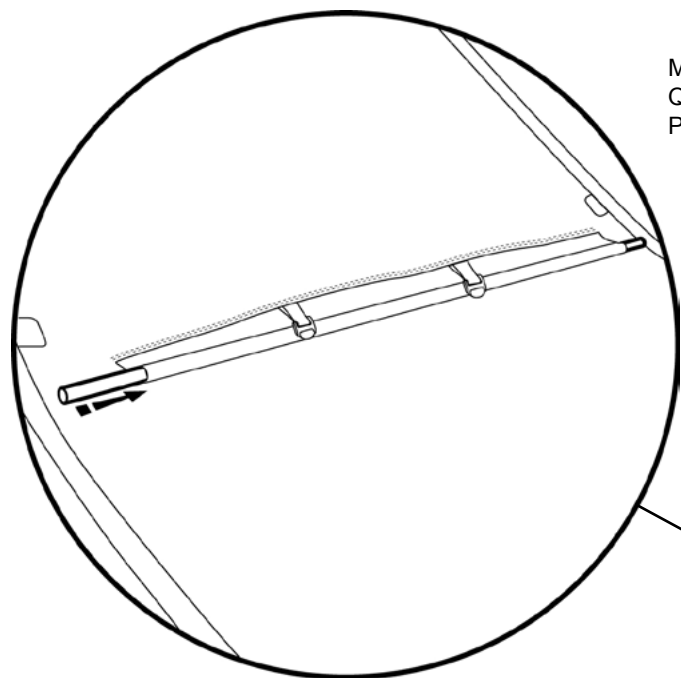

Middle Bow  
Qty - 1  
Part # 486.21



Bow Clip  
Qty - 1,  
Part # 479.22

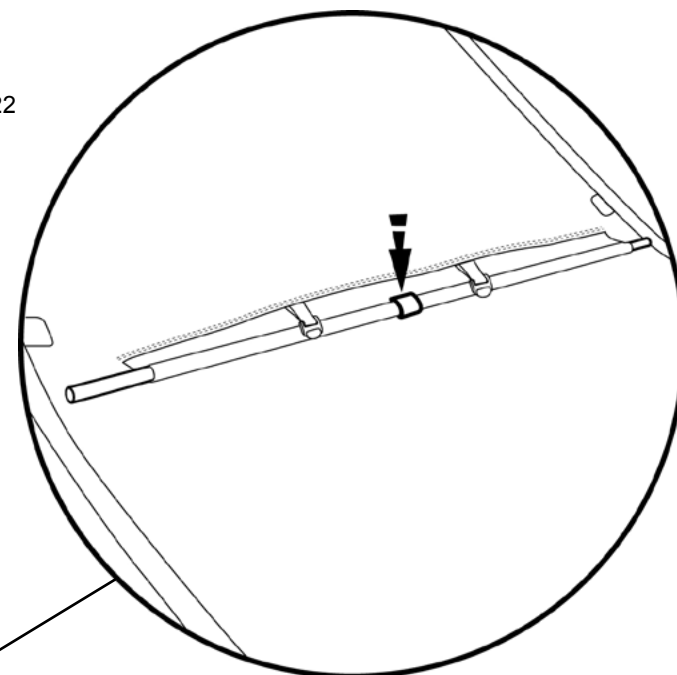

**Step 1**

Slide the Middle Bow into the sleeve inside the Top.

**Step 2**

Hook the Bow Clip to the Middle Bow to secure the fabric sleeve.



**Step 1** 460.37

**Hardware**

**Step 2**

Web Strap with  
Snap Hook  
Qty - 1 per side  
Part # 460.37

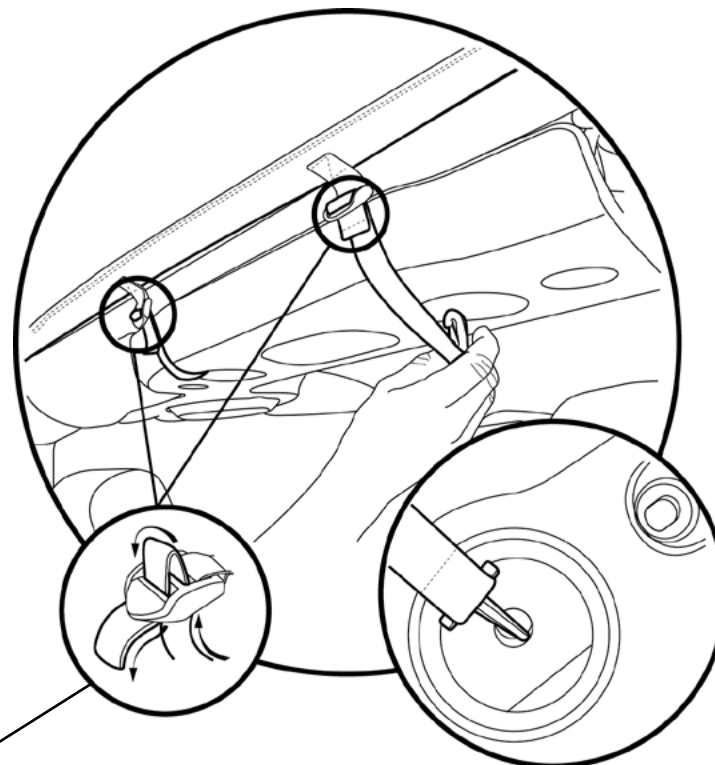
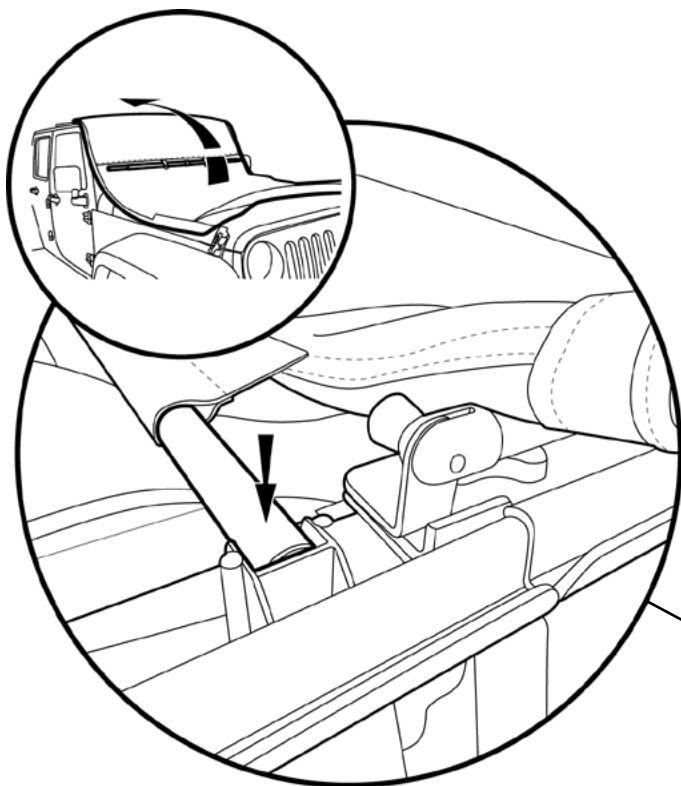

**Step 1**

Drape the Top Fabric over the Top Arches and the sport bars.

Make sure the Middle Bow is centered in the vehicle and sits in the slot in the Door Surround on each side.

Middle Bow fits snug to soundbar.

**Step 2**

Thread a Web Strap with Snap Hook through each buckle. Hook straps under into openings. Pull the ends of each strap to tighten securely.

Make sure Middle Bow is secure in slot before pulling Center Straps tight.



Step 1 486.18

Hardware

Step 2

Rear Bow  
Qty - 1  
Part # 486.18

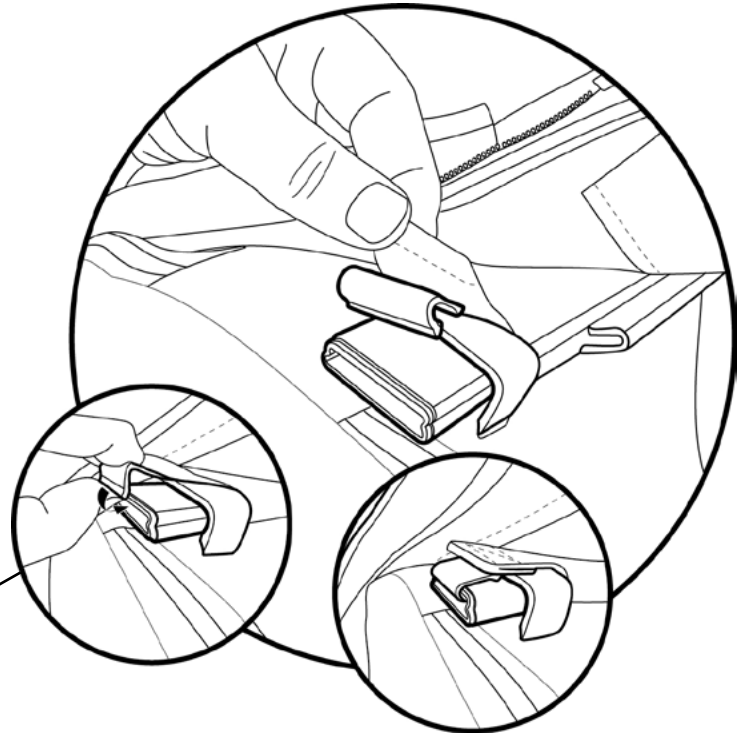
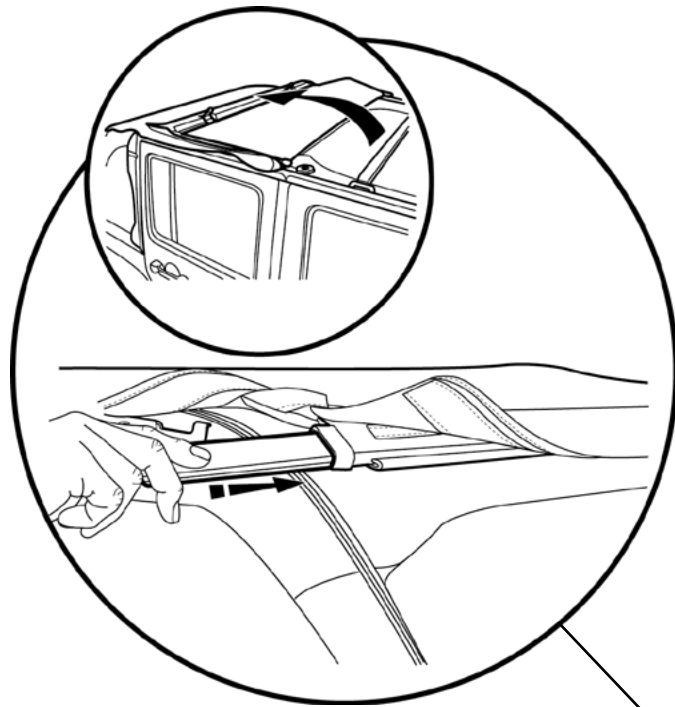

Step 1

Open Sunrider.  
Slide the Rear Bow into the pocket inside the rear of the Top Fabric. Slide the bow into the Rear Bow Brackets. Make sure it is centered between the brackets.

Step 2

Secure the J-Hooks on the rear bow flaps to the ends of the Rear Bow.  
Repeat on opposite side.

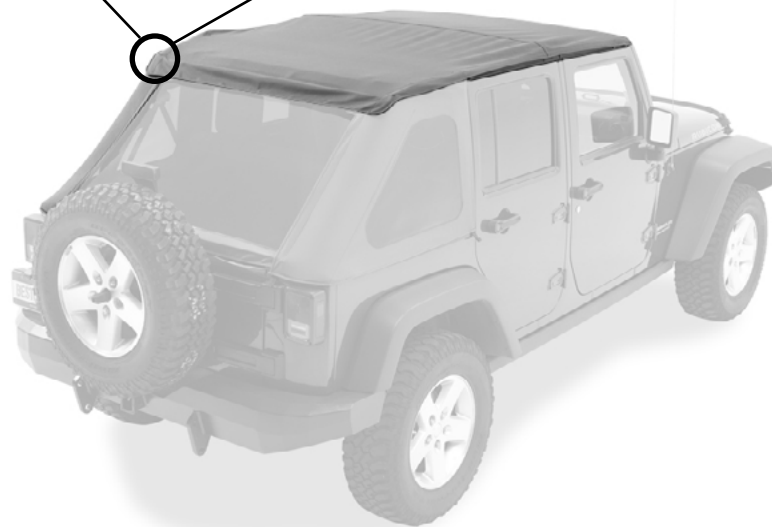

**Step 1**

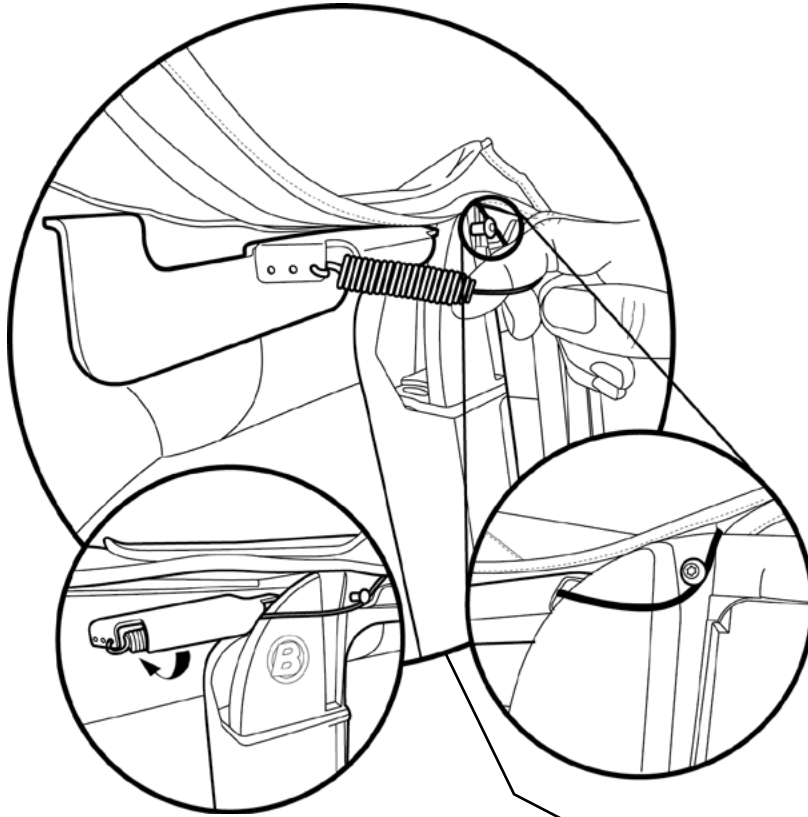

**Step 1**

Run the cable under the Door Surround screw and through the Cable Bracket. Hook the cable to the outer hole on the bracket.

To increase spring tension for a tighter fit, hook the spring into one of the inner holes in the Cable Bracket.

Repeat on opposite side.

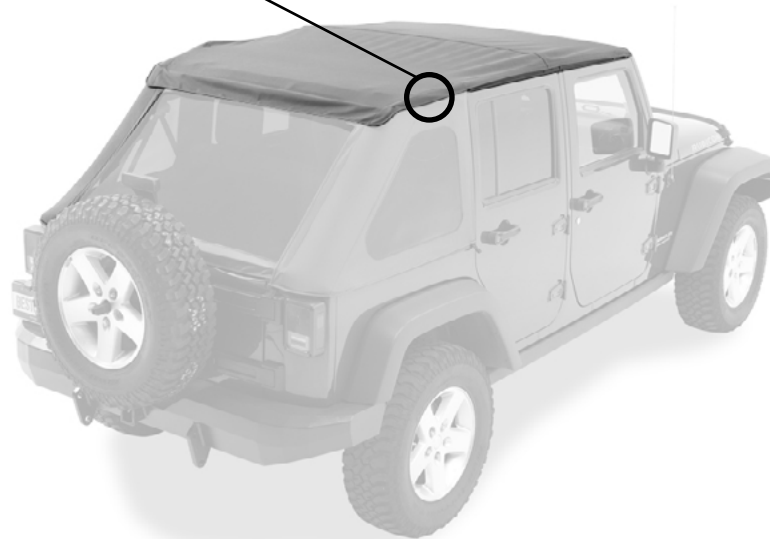



**Step 1**

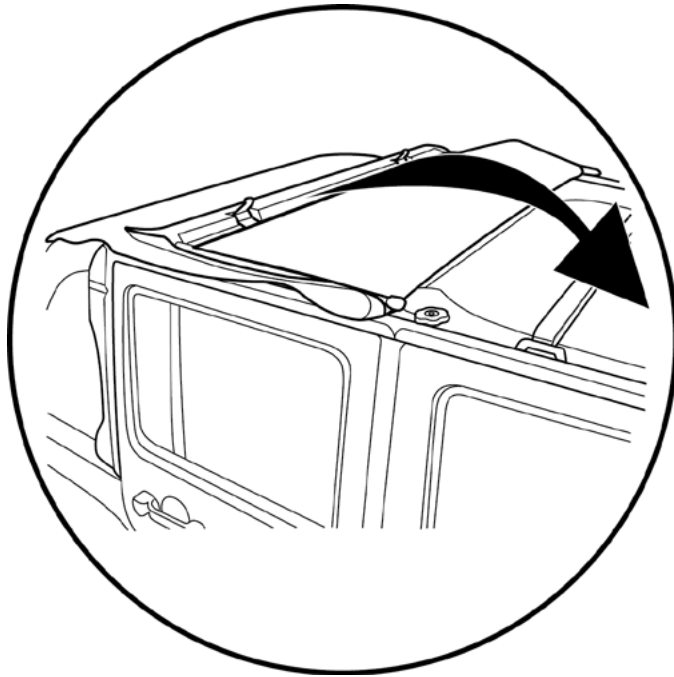

**Step 2**

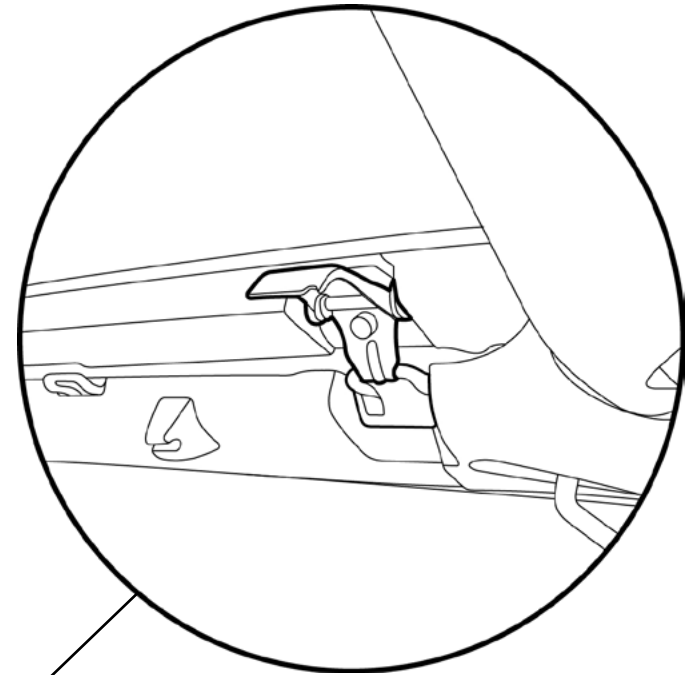

**Step 1**

Close Sunrider



**Step 2**

Hook the latches on the Header into the loops in the windshield. Do not close latch. Repeat on opposite side.

**Step 1**

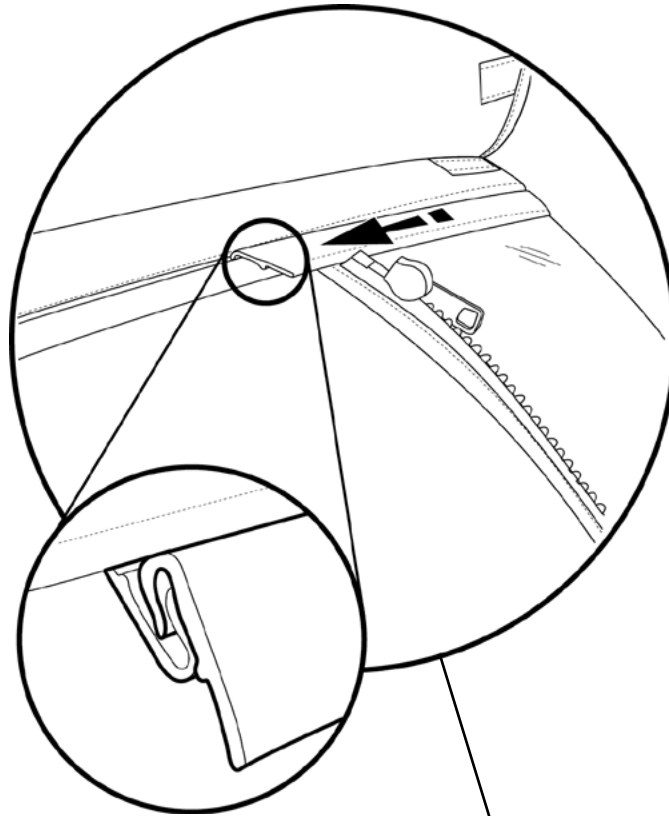

**Step 1**

Align the J-slide with the J-slide sewn into the rear of the Top. Slide them together until the Rear Window is centered in the opening.

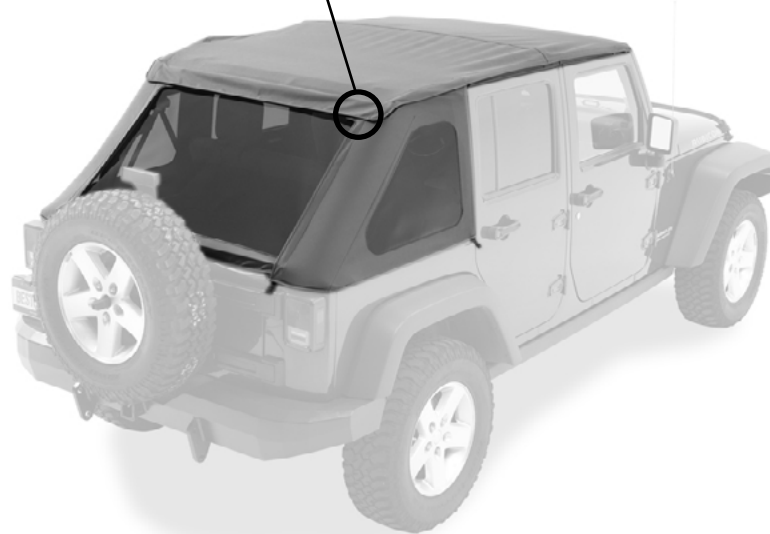

Step 1

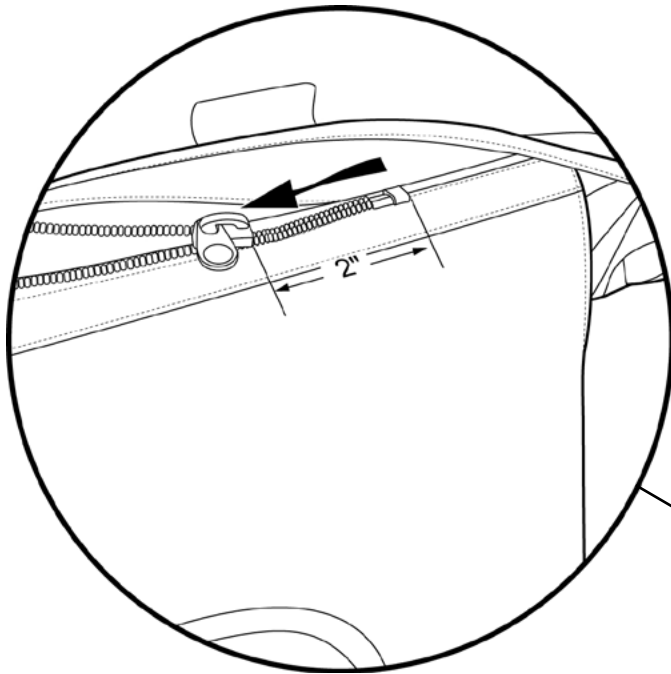

Step 2

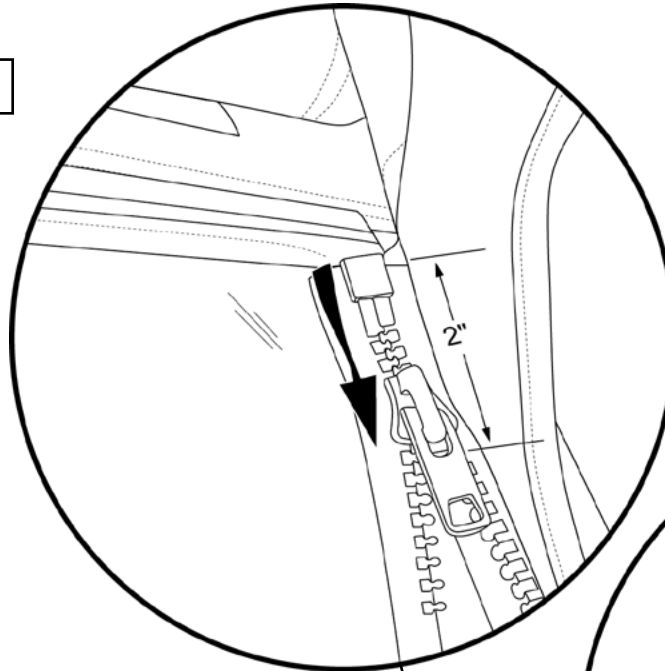

Step 3

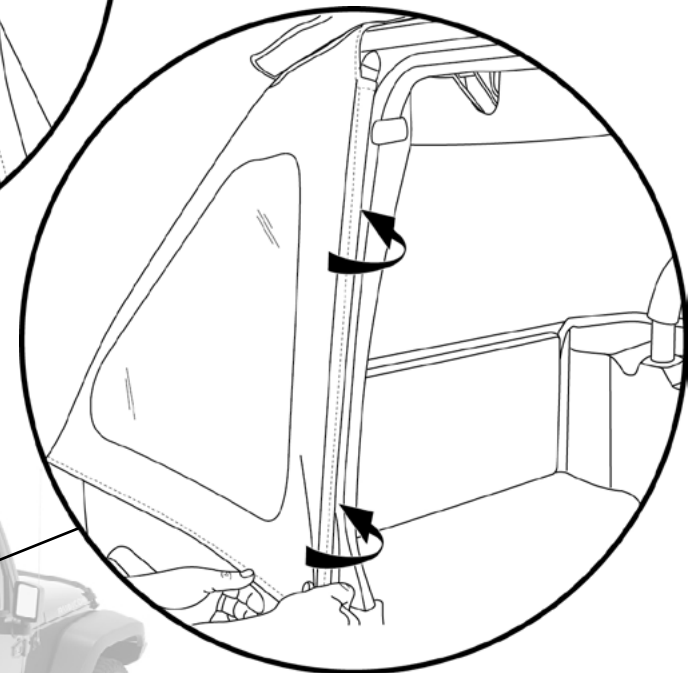

Step 1

Start the zipper along the top of the Side Window with the zipper in the Top. Only close the zipper 1-2".

Step 2

Engage the Rear Window zipper with the Quarter Panel zipper. Only close the zipper 1-2".

Repeat on opposite side.

Step 3

Slip the plastic strip on the front of a Side Window into the channel in the Door Surround. Repeat with both Side Windows.

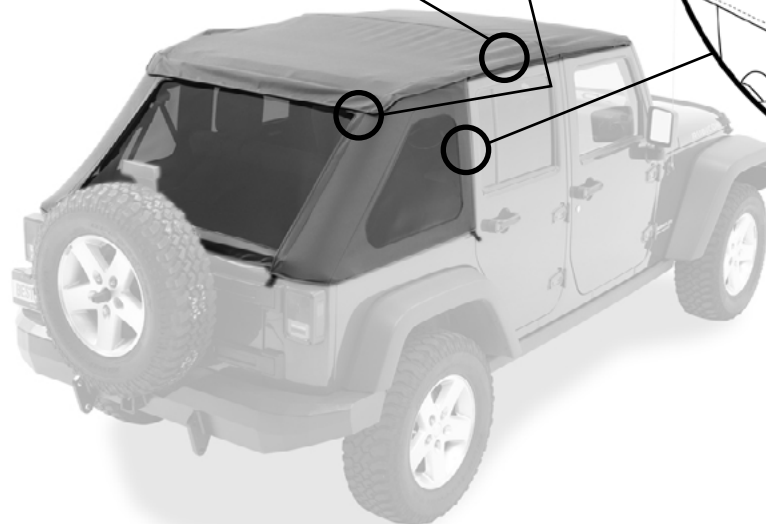

**Step 4**

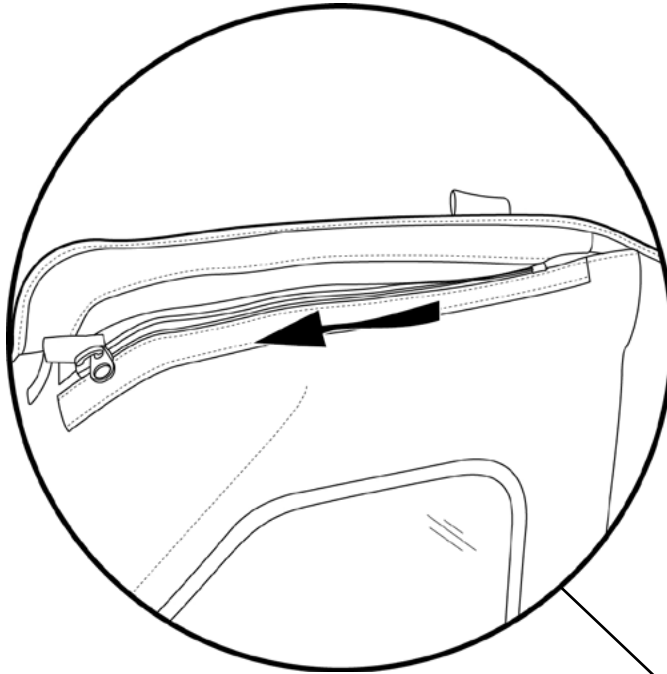

**Step 5**

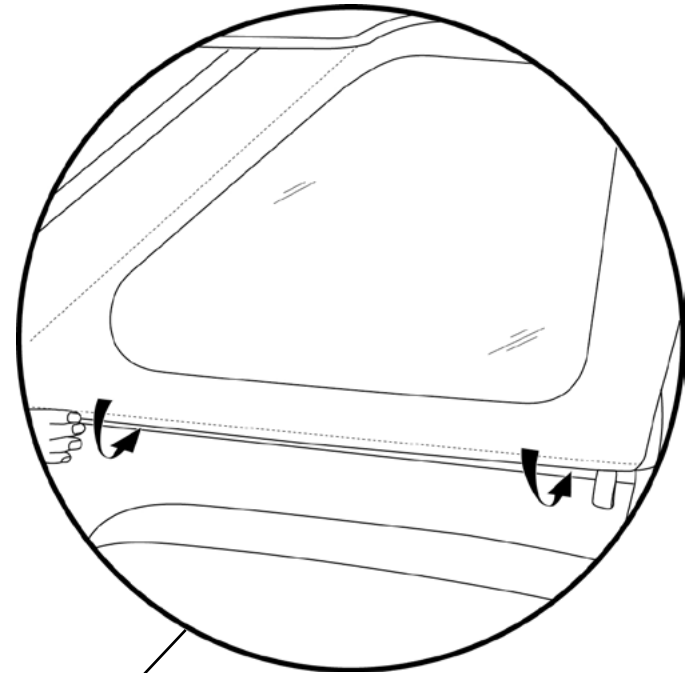

**Step 4**

Close the zippers along the top of each Side Window.

**Step 5**

Slip the plastic strip along the bottom of the Side Windows into the channel in the belt rail on each side of the vehicle.

Repeat on opposite side.

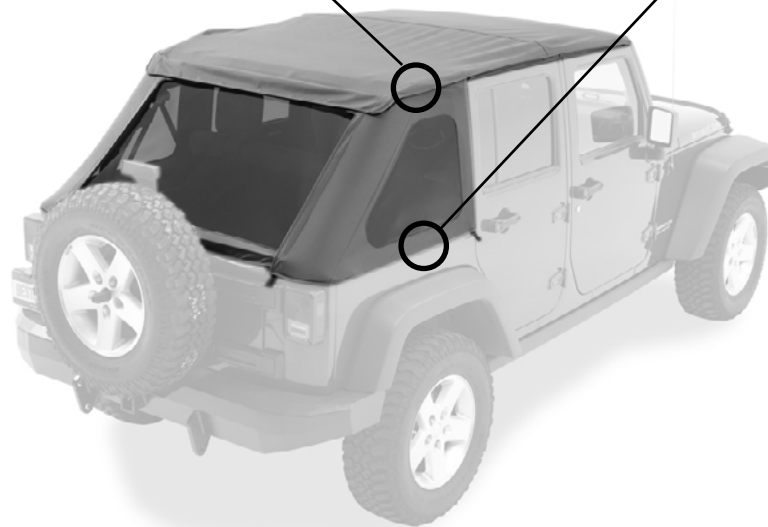

Step 1

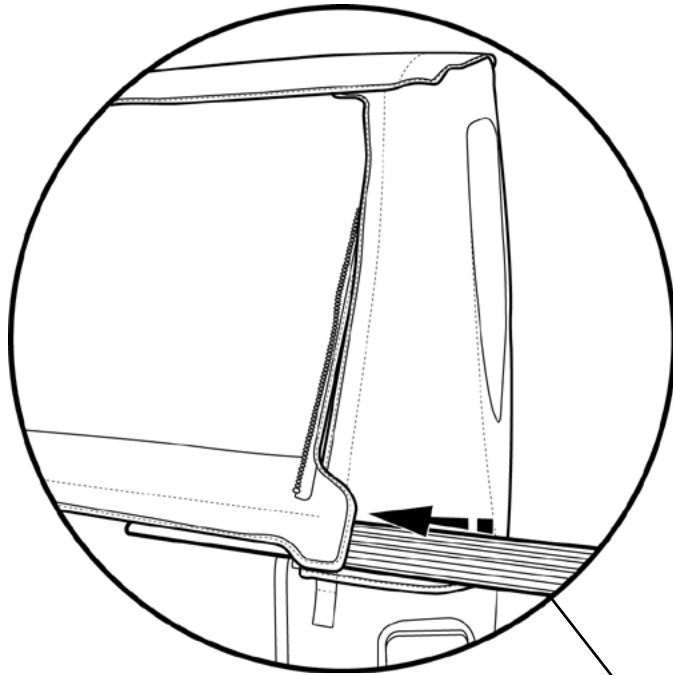

Hardware

Tailgate Bar  
Qty - 1  
Part # 489.46

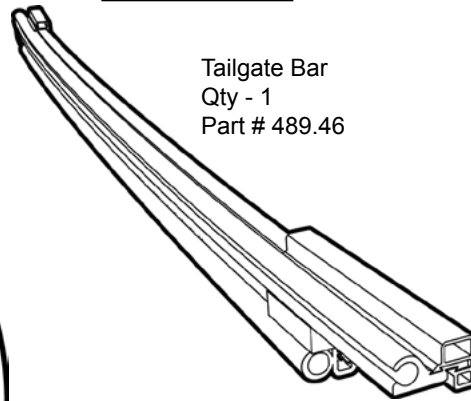

Step 2

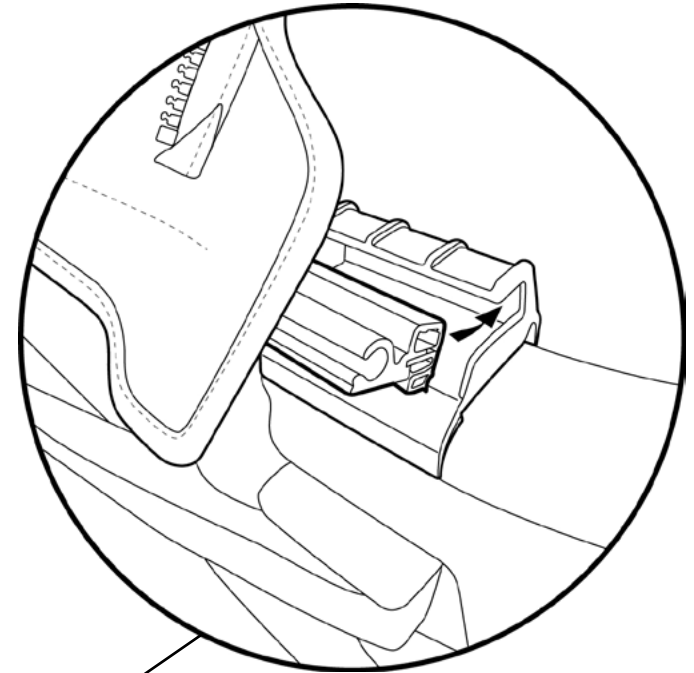

Step 1

Slide the channel in the Tailgate Bar onto the tubing along the bottom of the Rear Window on the inside.

Step 2

Slide the Tailgate Bar into the Tailgate Bar Mounts on each side of the tailgate opening.

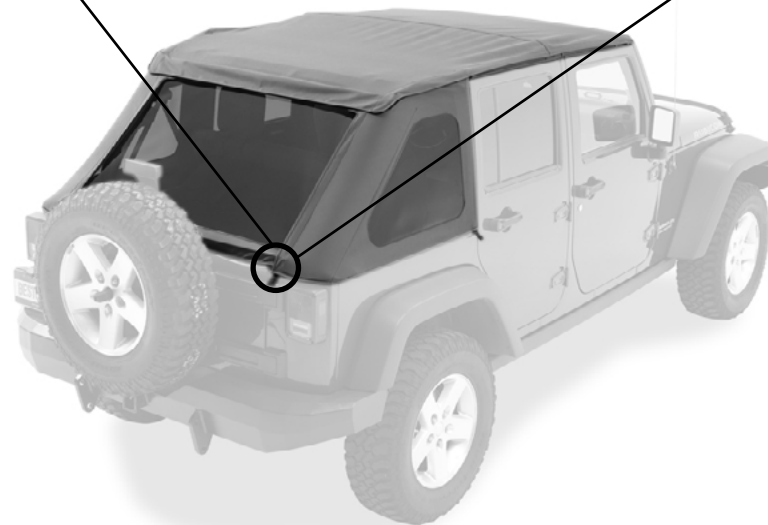

**Step 1**

**Step 2**

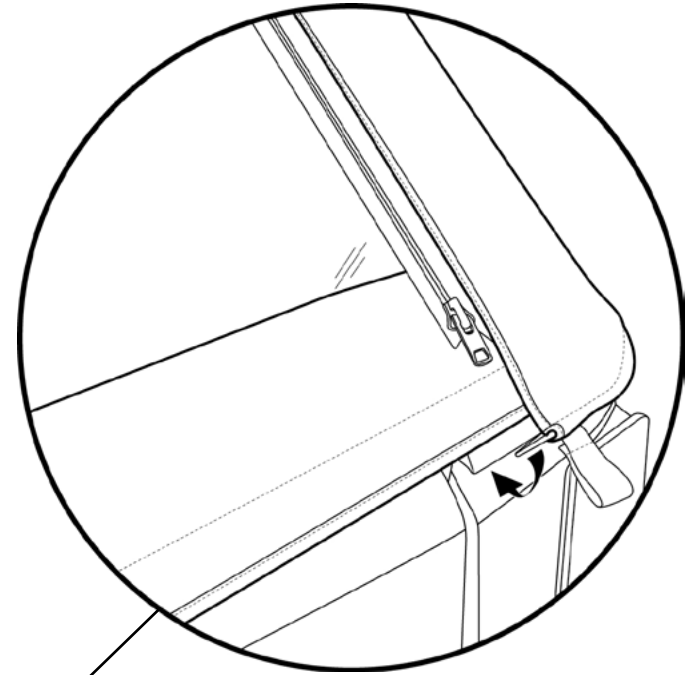
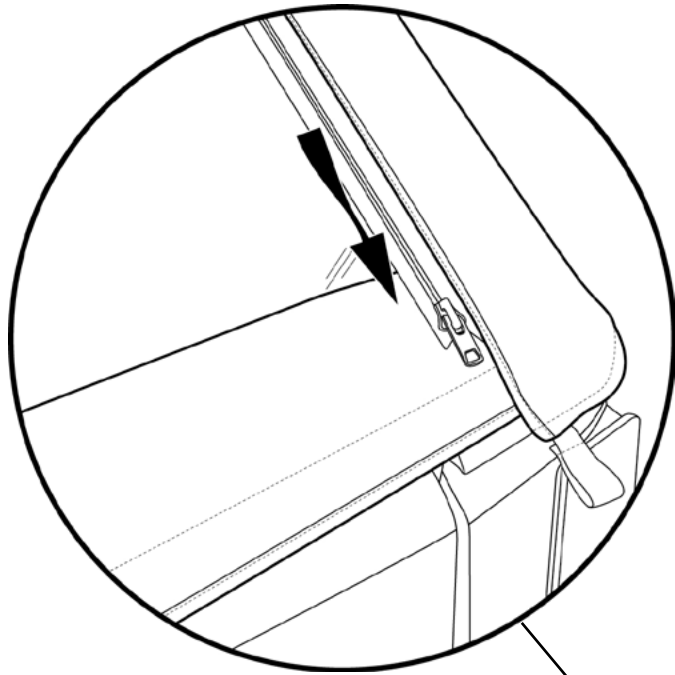

**Step 1**

Close the zippers on both sides of the Rear Window.

**Step 2**

Wrap the Side Windows over the Rear Window and slip the plastic strips on each Side Window under the Tailgate Bar Mounts on each side of the tailgate.

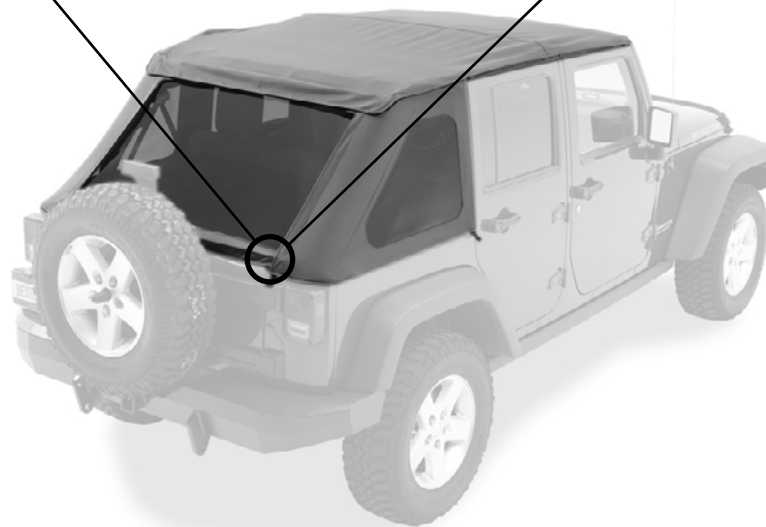

**Step 1**

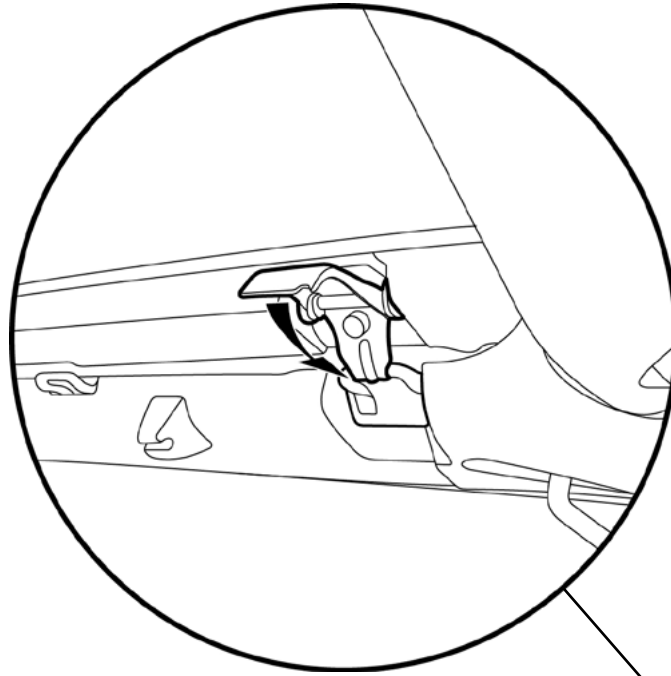

**Step 1**

Hook the latches on the Header into the loops in the windshield and close them.

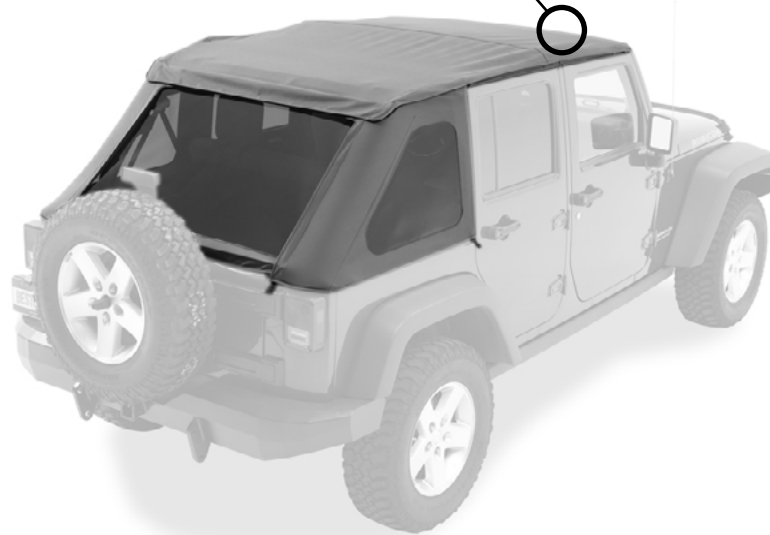



## Installation Instructions Trektop NX Twill

**Vehicle Application:**  
**Jeep Wrangler Unlimited (JK) 4 Door**  
2007 – Current  
Part Number: 56923

### Care and Maintenance of your Bestop Product

Your Bestop product is made of the finest materials available. To keep it looking new and for the maximum possible life, it will need periodic cleaning and maintenance.

**Fabric:** The fabric should be washed often using soap, warm water and a soft bristle brush. Rinse with clear water to remove all traces of soap. Bestop recommends using 303 CONVERTIBLE TOP Cleaning & Care Kit (part no. 30520) which is specially formulated to provide a total cleaning and protection system.

**Windows:** Keep windows clean to avoid scratching. DO NOT use a brush on the windows! Wash with a water-soaked cloth or sponge and a mild dishwashing detergent. Bestop recommends Bestop Vinyl Window Cleaner (part no. 11203-00), which safely cleans and protects vinyl windows and helps prevent UV damage. NEVER WIPE THE WINDOWS WHEN THEY ARE DRY. Be careful when cleaning snow or frost from the vinyl windows since they are easily scratched and may crack at low temperatures. DO NOT roll the sides or rear window in cold weather. The windows become stiff and will crack. Cracks caused by misuse in cold temperatures are not covered under warranty.

**Zippers:** Keeping zippers cleaned and lubricated with Bestop's Zipper Cleaner (part no. 11206-00) will help prevent damage and keep the zippers in smooth working condition. If a zipper opens behind the slider, the slider may have been spread apart. This problem can usually be repaired by using an ordinary pair of pliers to bring the sides back into parallel. Return slider to the end of the zipper in the normal Open position. Squeeze lightly at first and test the zipper. If the zipper continues to remain open squeeze more firmly with the pliers and try the zipper again. Repeat this procedure until the zipper operates correctly.

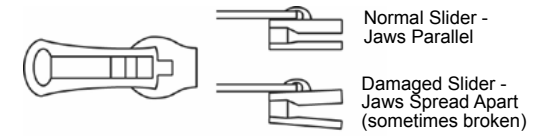

**Water:** Seeping through at the seams may be stopped by applying 3-M Scotchgard® on the inside of the seams. Rips in the fabric may be repaired with Bondex® iron on patches. Iron the patches to the Inside of the top, carefully following the Bondex® instructions.

**Snaps:** Keep snaps cleaned and lubricated with silicone to help prevent snaps from sticking to the studs. If a snap does become stuck to a stud, use a screwdriver and GENTLY pry apart to prevent permanent damage to the snap or the top fabric.

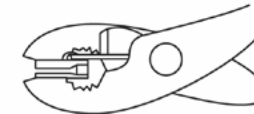

### BESTOP TWILL SOFT TOP LIMITED LIFETIME WARRANTY

**As long as the original purchaser owns the vehicle upon which the top was originally installed.**

We warrant our product to be free from defects in material and workmanship, for the terms specified below, provided there has been normal use and proper maintenance. This warranty applies to the original purchaser only. All remedies under this warranty are limited to the repair or replacement of any item or items found by the factory to be defective within the time period specified. If you have a warranty claim, first you must call our factory at the number below for instructions. You must retain proof of purchase and submit a copy with any items returned for warranty work. Upon completion of warranty work, if any, we will return the repaired or replaced item or items to you freight prepaid. Damage to our products caused by accidents, fire, vandalism, negligence, misinstallation, misuse, Acts of God, or by defective parts not manufactured by us, is not covered under this warranty.

**What's covered?** All defects in materials or workmanship on Bestop Twill products. This warranty does not apply to other Bestop products. This warranty and any implied warranties including merchantability and fitness for a particular purpose, lasts as long as the original retail purchaser owns the vehicle upon which the product is installed. The warranty expires should the product be removed from the original vehicle or if the original vehicle is transferred to another owner. This warranty is not transferable.

**What Bestop will do:** During the warranty period as written above, Bestop shall, at its option, either repair or replace any defective product at no charge. Bestop will not pay for labor charges associated with installation or removal of the product. Should a specific product be discontinued, Bestop may, at its option replace the discontinued product with a current product or like product.

The Warranty does not cover: Damage, defect, or malfunction caused by misuse, abuse, accident, fire, improper installation, modification, improper or inadequate maintenance, or hazards, or acts of God. Incidental or consequential damages are not covered under this warranty. Some states do not allow exclusion or limitation, so this may not apply to you. This warranty gives you specific legal rights, and you may have other rights which vary from state to state.

**Warranty Service:** Retain your proof of purchase. Proof of purchase must accompany any warranty claim. A defective item should be returned to the place of purchase. Bestop's Customer Service may be contacted for help determining whether a product is defective. Bestop Customer Service may be reached at 1-800-845-3567, or vis e-mail at [cs@bestop.com](mailto:cs@bestop.com).

Some states do not allow limitations on how long an implied warranty lasts, or the exclusion or limitation of incidental or consequential damages, so the above limitations or exclusions may not apply to you. This warranty gives you specific legal rights, and you may also have other rights which vary from state to state.

For further information or request for warranty work, please contact Bestop Inc., Customer Service:

Toll-Free: (800) 845-3567

Main: (303) 465-1755

E-mail: [csbestop@Bestop.com](mailto:csbestop@Bestop.com)

Website: [www.Bestop.com](http://www.Bestop.com)





## Installation Instructions Trektop NX Twill

Vehicle Application:  
Jeep Wrangler Unlimited (JK) 4 Door  
2007 – Current  
Part Number: 56923

### Cuidado y mantenimiento de su producto Bestop

Su producto Bestop está hecho con materiales de la más alta calidad. Para mantener su aspecto nuevo y alargar su vida útil al máximo posible, necesitará limpieza y mantenimiento periódicos.

**Tela:** debe lavar la tela con frecuencia usando jabón, agua tibia y un cepillo de cerdas suaves. Enjuague con agua limpia para eliminar todos los residuos de jabón. Bestop recomienda utilizar el kit de limpieza y cuidado 303 CONVERTIBLE TOP (número de parte 30520), que está formulado especialmente para ofrecer un sistema de limpieza y protección total.

**Ventanas:** mantenga las ventanas abiertas para evitar que se rayen. ¡NO use cepillo para lavar las ventanas! Lave con un paño o esponja empapado de agua y un detergente suave para lavar platos. Bestop recomienda usar el limpiador de ventanas de vinilo Bestop (número de parte 11203-00), que limpia de manera segura y protege las ventanas de vinilo, además de ayudar a prevenir daños causados por los rayos UV. NUNCA LIMPIE LAS VENTANAS CUANDO ESTÉN SECAS. Tenga cuidado cuando limpie la nieve o escarcha de las ventanas de vinilo, ya que se rayan con facilidad y pueden agrietarse a temperaturas bajas. NO baje las ventanas laterales o la ventana de la parte posterior cuando haga frío. Las ventanas pueden ponerse rígidas y agrietarse. Esta garantía no cubre las grietas causadas por mal uso en temperaturas frías.

**Cremalleras:** conserve las cremalleras limpias y lubricadas con el limpiador de cremalleras Bestop (número de parte 11206-00), que ayuda a prevenir daños y mantiene las cremalleras en óptimas condiciones de funcionamiento. Si la cremallera se abre detrás de la corredera, es posible que las mordazas de la corredera se hayan separado. Por lo general, este problema se repara fácilmente con un par de pinzas comunes para volver a poner los lados en paralelo. Regrese la corredera al extremo de la cremallera en la posición abierta normal. Apriete un poco al principio y pruebe la cremallera. Si la cremallera sigue abierta, apriete con mayor firmeza con las pinzas y vuelva a probar la cremallera. Repita este procedimiento hasta que la cremallera funcione correctamente.

**Agua:** para eliminar la filtración de agua por las costuras, aplique cinta Scotchgard® de 3-M en la parte interior de las costuras. Los rasgones de la tela pueden repararse con parches Bondex® que se aplican con plancha. Plancha los parches en el interior de la capota, siguiendo con cuidado las instrucciones de Bondex®.

**Broches:** conserve los broches limpios y lubricados con silicona para evitar que se peguen a los corchetes de encaje. Si un broche se queda pegado a un corchete, use un destornillador y CON CUIDADO separe las dos piezas para evitar daño permanente al broche o a la tela de la capota.

Corredera normal: Mordazas paralelas    Corredera dañada: Mordazas abiertas (a veces, rotas)

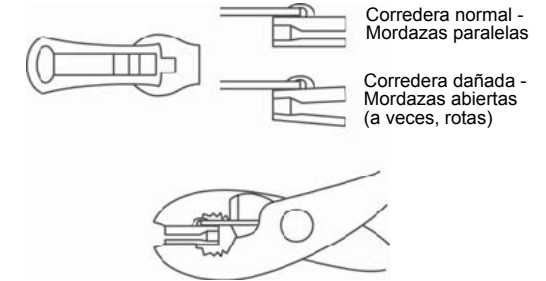

### GARANTÍA LIMITADA DE POR VIDA DE LA CAPOTA DE TELA ASARGADA BESTOP

Siempre que el comprador original siga siendo dueño del vehículo en el cual se instaló originalmente la capota.

Garantizamos que nuestro producto estará exento de defectos en materiales y mano de obra, durante los plazos que se especifican a continuación, siempre que se le haya dado el uso normal y el mantenimiento adecuado. Esta garantía aplica únicamente al comprador original. Todos los recursos previstos en esta garantía se limitan a la reparación o sustitución de cualquier elemento o elementos que la fábrica determine que presentan defectos dentro del período especificado. Si desea presentar una reclamación de garantía, primero debe llamar a nuestra fábrica al número que se indica a continuación para recibir instrucciones. Debe conservar el comprobante de compra y enviar una copia con los artículos devueltos para reparación de garantía. Al término del trabajo de garantía, si lo hubo, devolveremos el o los artículos reparados o sustituidos a su domicilio con flete prepagado por usted. Esta garantía no cubre los daños que sufran nuestros productos a causa de accidentes, incendio, vandalismo, negligencia, errores de instalación, mal uso, causas de fuerza mayor, o que sean provocados por partes defectuosas que no fabricamos nosotros.

**¿Qué cubre esta garantía?** Todos los defectos en materiales y mano de obra de los productos de tela asargada Bestop. Esta garantía no aplica a otros productos de Bestop. Esta garantía y todas las garantías implícitas, incluidas las de comerciabilidad e idoneidad para un fin determinado, estarán vigentes durante todo el tiempo que el comprador original del producto siga siendo dueño del vehículo en el cual está instalado el producto. La garantía caducará en caso de que el producto se retire del vehículo original, o si el vehículo original se traspasa a otro propietario. Esta garantía no es transferible.

**Lo que Bestop hará.** Durante el período de garantía especificado anteriormente, Bestop, a su elección, reparará o sustituirá los productos defectuosos sin ningún costo para el cliente. Bestop no pagará los gastos de mano de obra relacionados con la instalación o retiro del producto. En caso de que se llegara a discontinuar un producto específico, Bestop puede, a su elección, sustituir el producto discontinuado con un producto actual o semejante.

**La garantía no cubre:** Daños, defectos o fallas de funcionamiento causados por mal uso, abuso, accidente, incendio, errores de instalación, modificación, mantenimiento incorrecto o insuficiente, o por riesgos o causas de fuerza mayor. Los daños incidentales o resultantes no están cubiertos por esta garantía. En algunos estados no se permiten exclusiones o limitaciones, por lo que esto puede no ser aplicable a usted. Esta garantía le confiere derechos legales específicos, y también puede tener otros derechos, los cuales varían de un estado a otro.

**Servicio de garantía:** Conserve su comprobante de compra. Toda reclamación de garantía debe ir acompañada del comprobante de compra. El artículo defectuoso debe devolverse al lugar de compra. Puede consultar al área de Atención a clientes de Bestop para que le ayude a determinar si el producto tiene defectos. Para comunicarse con un representante de atención a clientes de Bestop, le agradeceremos llamar al 1-800-845-3567, o escribir por correo electrónico a [cs@bestop.com](mailto:cs@bestop.com).

En algunos estados no se permiten limitaciones respecto a la duración de las garantías implícitas, ni la exclusión o limitación de los daños incidentales o resultantes, por lo que las limitaciones o exclusiones anteriores pueden no ser aplicables a usted. Esta garantía le confiere derechos legales específicos, y también puede tener otros derechos, los cuales varían de un estado a otro.

Para obtener más información o solicitar un trabajo de garantía, comuníquese con:

Bestop Inc., Atención a Clientes    Número para llamar sin costo: (800) 845-3567    Conmutador: (303) 465-1755    Correo electrónico: [csbestop@Bestop.com](mailto:csbestop@Bestop.com)    Sitio Web: [www.Bestop.com](http://www.Bestop.com)



## Installation Instructions Trektop NX Twill

**Vehicle Application:**  
**Jeep Wrangler Unlimited (JK) 4 Door**  
2007 – Current  
Part Number: 56923

### Soin et entretien de votre produit Bestop

Votre produit Bestop est fabriqué des meilleurs matériaux disponibles. Il devra être nettoyé et entretenu régulièrement afin de maintenir son apparence neuve et pour une durée d'utilisation maximale.

**Tissu :** Le tissu doit être lavé régulièrement à l'aide de savon, d'eau chaude et d'une brosse à soies douces. Rincer à l'eau claire afin d'éliminer toute trace de savon. Bestop recommande l'utilisation de la trousse de nettoyage et d'entretien 303 CONVERTIBLE TOP (no de pièce 30520), laquelle est spécialement formulée pour fournir un système de nettoyage et de protection complet.

**Vitres :** Maintenir les vitres propres pour éviter de les égratigner. NE PAS utiliser une brosse sur les fenêtres. Laver avec un chiffon ou une éponge imbibée d'eau et d'un savon à vaisselle doux. Bestop recommande Bestop Vinyl Window Cleaner (no de pièce 11203-00), lequel nettoie et protège les vitres de vinyle et aide à prévenir les dommages causés par les UV. NE JAMAIS ESSUYER LES VITRES ALORS QU'ELLES SONT SÈCHES. Prendre soin de bien enlever la neige ou le givre des vitres de vinyle parce qu'elles peuvent être égratignées facilement et peuvent fissurer à de basses températures. NE PAS rouler les vitres latérales ou arrière par temps froid. Les vitres deviennent dures et elles fissureront. Les fissures causées par une mauvaise utilisation par temps froid ne sont pas couvertes par la garantie.

**Fermetures à glissière :** Maintenir les fermetures à glissière propres et lubrifiées à l'aide du nettoyeur Zipper Cleaner (no de pièce 11206-00) de Bestop aidera à protéger des dommages et maintiendra les fermetures à glissière en bon état de fonctionnement. Si une fermeture à glissière ouvre derrière la glissière, la glissière peut avoir été forcée au point de s'ouvrir. Le problème peut habituellement être réparé en utilisant des pinces ordinaires pour remettre les côtés parallèles. Remettre la glissière au bout de la fermeture à glissière, dans la position Ouverte normale. Serrer légèrement au début et vérifier le fonctionnement de la fermeture à glissière. Si la fermeture à glissière continue de rester ouverte, serrer plus fortement à l'aide des pinces et essayer la fermeture à glissière de nouveau. Répéter le processus jusqu'à ce que la fermeture à glissière fonctionne correctement.

**Eau :** Les infiltrations d'eau aux coutures peuvent être arrêtées par l'application de Scotchgard® 3M sur l'intérieur des coutures. Les déchirures dans le tissu peuvent être réparées grâce aux pièces thermocollantes Bondex®. Fixer les pièces thermocollantes à l'aide d'un fer à repasser sur l'intérieur du toit, en suivant soigneusement les instructions de Bondex®.

**Boutons pression :** Maintenir les boutons pression propres à l'aide de silicone pour empêcher les boutons pression de coller aux rivets. Si un bouton pression reste collé à un rivet, utiliser un tournevis et appliquer une FAIBLE PRESSION afin d'éviter d'endommager le bouton pression ou le tissu du toit.

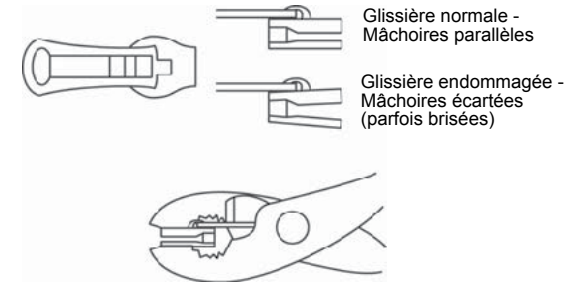

### GARANTIE À VIE LIMITÉE POUR TOIT CONVERTIBLE EN TISSU CROISÉ BESTOP

Aussi longtemps que l'acheteur initial possède le véhicule sur lequel le toit a été installé à l'origine. Nous garantissons que notre produit est exempt de défauts de matériaux et de fabrication, pour les modalités précisées ci-dessous, pourvu qu'il ait été utilisé de façon normale et entretenu de manière adéquate. Cette garantie s'applique à l'acheteur original seulement. Tous les recours sous cette garantie sont limités à la réparation ou au remplacement de tout article ou articles reconnus par l'usine comme étant défectueux pendant la période de temps spécifiée. Si vous devez faire une réclamation, vous devez d'abord appeler notre usine au numéro ci-dessous pour obtenir des instructions. Vous devez conserver la preuve d'achat et en transmettre une copie avec tous les articles retournés pour réparation sous garantie. À la fin des travaux de garantie, le cas échéant, nous vous retournerons l'article ou les articles réparés ou remplacés en port payé à l'avance. Les dommages à nos produits causés par les accidents, les incendies, le vandalisme, la négligence, une mauvaise utilisation, une mauvaise installation, les cas fortuits ou par des pièces défectueuses qui ne sont pas fabriqués par nous, ne sont pas couverts par cette garantie.

Qu'est-ce qui est couvert? Tous les défauts de matériaux ou de fabrication des produits de tissu croisé Bestop. Cette garantie ne s'applique pas aux autres produits Bestop. Cette garantie, et toute garantie implicite, y compris marchande et d'adéquation à un usage particulier, dure aussi longtemps que l'acheteur original au détail est propriétaire du véhicule sur lequel le produit est installé. La garantie expire si le produit est retiré du véhicule d'origine ou si le véhicule d'origine est transféré à un autre propriétaire. Cette garantie est incessible.

Ce que Bestop fera. Pendant la période de garantie décrite ci-dessus, Bestop réparera ou remplacera, à sa discrétion, tout produit défectueux sans frais. Bestop ne paiera pas pour les frais de main-d'œuvre associés à l'installation ou le retrait du produit. Si un produit spécifique est abandonné, Bestop peut, à sa discrétion, remplacer le produit abandonné par un produit actuel ou un produit similaire.

La garantie ne couvre pas : Les dommages, défauts ou dysfonctionnements causés par une mauvaise utilisation, l'abus, un accident, un incendie, une mauvaise installation, une modification, un entretien incorrect ou inadéquat, ou les dangers ou les cas de force majeure. Les dommages accessoires ou indirects ne sont pas couverts par cette garantie. Certains états n'autorisent pas l'exclusion ou la limitation, donc cela peut ne pas s'appliquer à vous. Cette garantie vous donne des droits légaux spécifiques, et vous pouvez également avoir d'autres droits qui varient d'une province à l'autre et d'un territoire à l'autre.

Service de garantie : Conserver votre preuve d'achat. La preuve d'achat doit accompagner toute réclamation. Un article défectueux doit être retourné à l'endroit de l'achat. Communiquer avec le service à la clientèle Bestop pour vous aider à déterminer si un produit est défectueux. S'adresser au service à la clientèle Bestop en composant le 1-800-845-3567 ou par courriel à [cs@bestop.com](mailto:cs@bestop.com). Certaines provinces et certains territoires n'autorisent pas les limitations sur la durée d'une garantie implicite, ou l'exclusion ou la limitation des dommages accessoires ou indirects, et il se pourrait donc que les limitations ou exclusions susmentionnées ne s'appliquent pas à vous. Cette garantie vous donne des droits légaux spécifiques, et vous pouvez également avoir d'autres droits qui varient d'une province à l'autre et d'un territoire à l'autre.

Pour de plus amples renseignements et demander une réparation, communiquer avec :

Le service à la clientèle Bestop Inc.

Sans frais : (800) 845-3567

Local : (303) 465-1755

Courriel : [csbestop@Bestop.com](mailto:csbestop@Bestop.com)

Site Web : [www.Bestop.com](http://www.Bestop.com)