



INSTALLATION INSTRUCTIONS

MAKE: BMW
MODEL: 335i (F30)
YEAR: 2012-2013
ENGINE: L6-3.0L (t) N55

DOWN-PIPE
304 Stainless Steel
48-36310 w/ Cats
48-36311 w/o Cats

aFe recommends professional installation on our products.

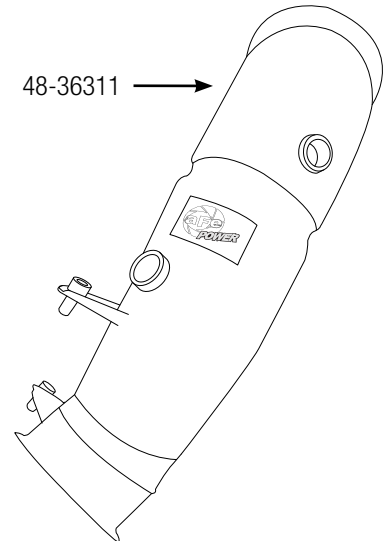
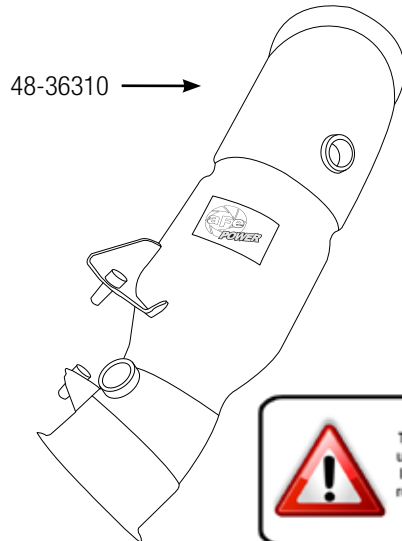

Caution: Allow time for your vehicle to cool down prior to installation. When working on or under your vehicle proceed with caution. Exhaust systems reach high temperatures and may cause serious burns. Wear protective safety equipment; eye goggles and gloves to ensure a safe installation.

- Step 1:** Secure vehicle on jack stands (Refer to your manual for specified jack stand positions).
- Step 2:** Remove the center brace under the O.E. exhaust system.
- Step 3:** Un-plug the actuator drive at the rear of the O.E. muffler.
- Step 4:** Loosen the band clamp securing the O.E. mid pipe to the catalytic converter.
- Step 5:** Un-bolt all rubber hanger mounts off the chassis and remove O.E. exhaust system.
- Step 6:** Remove the catalytic converter bracket secured to the transmission case and catalytic converter.
- Step 7:** Remove both front and rear oxygen sensors.
- Step 8:** Remove the turbo band clamp securing the catalytic converter to the turbo.
- Step 9:** Remove catalytic converter.
- Step 10:** Remove the OE gasket off the catalytic converter and transfer onto the aFe Down Pipe (Replace if necessary).
- Step 11:** Install the aFe Down Pipe using the original turbo band clamp but do not tighten.
- Step 12:** Install the front and rear oxygen sensors onto the aFe Down Pipe and tighten.
- Step 13:** Install the original bracket removed from step 6 but do not tighten.
- Step 14:** Tighten the turbo band clamp from step 11 and then the bracket from step 13.
- Step 15:** Install the O.E. exhaust system using the original nuts and bolts from step 5 and tighten.
- Step 16:** Tighten the band clamp securing the O.E. mid pipe to the aFe Down Pipe.
- Step 17:** Plug the actuator drive wire harness back onto the actuator drive unit.
- Step 18:** Install the center brace and tighten.
- Step 19:** Re-check all your work.
- Step 20:** Remove vehicle off jack stands.

NOTE: It is normal for the aFe Turbo Down Pipe to emit smoke for the first few minutes upon initial start-up.
