



YOSHIMURA

RESEARCH & DEVELOPMENT OF AMERICA, INC.

5420 DANIELS STREET STE A, CHINO CA., 91786 · (800)634-9166 · (909)628-4722 · FACSIMILE (909)591-2198

www.yoshimura-rd.com

RS-3 OVAL PERFORMANCE EXHAUST SYSTEM

SUZUKI
2000-04
DR-Z400S^V

2165600-SA STAINLESS STEEL COMPETITION SLIP-ON SYSTEM



THIS PRODUCT IS DESIGNED FOR USE IN CLOSED COURSE RACING AND IS NOT INTENDED FOR HIGHWAY USE.



NOTE: IN THE STATE OF CALIFORNIA, IT IS ILLEGAL TO MODIFY THE EMISSION CONTROL SYSTEM, WHICH INCLUDES THE CARBURETORS OF ANY VEHICLE.

Caution: Exhaust system can be extremely hot. Let motorcycle cool down before beginning installation.

Note: Read through all instructions before beginning installation.

Tools Needed:

8mm, 10mm and 12mm sockets
3/8" ratchet and extension
4mm and 6mm Allen bit for torque wrench
12mm Wrench
Torque wrench

Installation Steps:

- 1 Remove right rear number plate and header heat shield. (See Fig. 1 for fastener locations.)
- 2 Remove stock muffler assembly. (See Fig. 2 for fastener locations.)
- 3 Install supplied exhaust joint connector gasket into Yoshimura tail-pipe.
- 4 Slide stock exhaust clamp over inlet of slip-on tail-pipe. (See Fig.3)
- 5 Remove stock chassis mount insert and insert from outside. (See Fig 4)
- 6 Install Yoshimura tail-pipe with muffler onto stock header.
- 7 Bolt tail-pipe to chassis mount using supplied bolt. Do not tighten bolt at this point. (See Fig. 3)
- 8 Apply heat insulator to inside of muffler clamp and slide clamp onto muffler. (Note direction of clamp in Fig. 6)

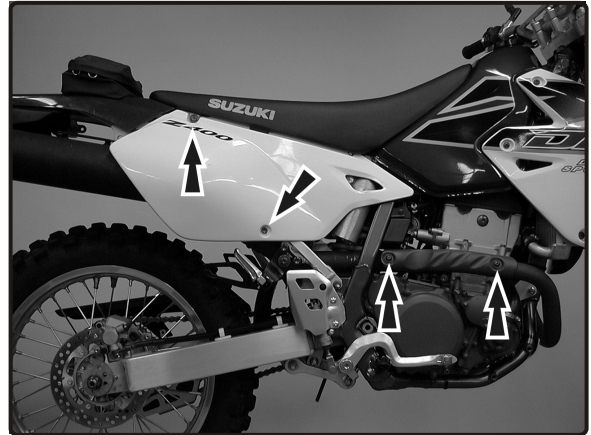

Fig. 1

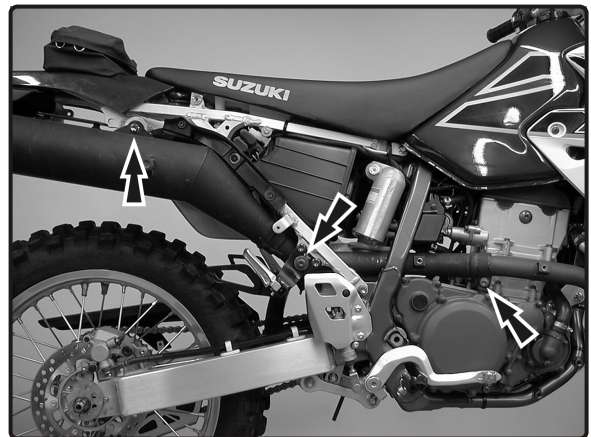

Fig. 2

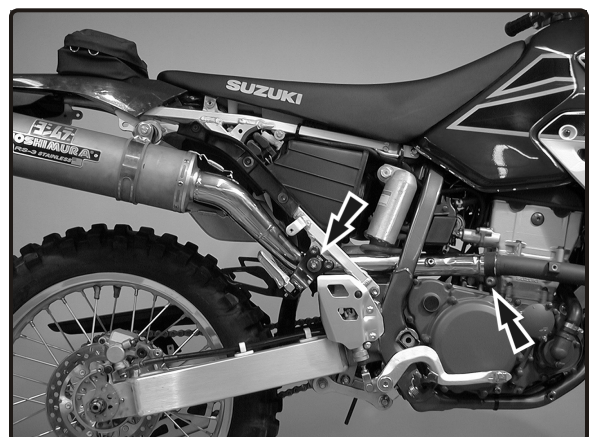

Fig. 3

- 8 Mount muffler clamp to chassis using supplied bolt, washers, steel spacer, aluminum spacer and stock nut. Torque bolt to 2.5 kg-m (18 lb-ft). (See Fig. 5 and 6 for assembly order and location.)
- 9 Torque chassis mount bolt to 2.5 kg-m (18 lb-ft)
- 10 Torque stock exhaust clamp to 1.25kg-m (9lb-ft).
- 11 Re-install stock heat shield onto stock header and Yoshimura tail-pipe using stock bolts and washers.
- 12 It is recommended that the muffler and tail-pipe be wiped down with rubbing alcohol to remove oil and Fingerprints. This will help prevent tarnishing of the Finish after the exhaust is heated up.
- 13 Before starting motorcycle check for proper clearance between new exhaust system and rear suspension (i.e. rear brake, frame, shock spring, etc). If any problem is found, please carefully follow through the installation steps again. If problem still persists, please call Yoshimura tech. Dept. at (800)634-9166 / in CA (909) 628-4722
- 14 Reinstall number plate and stock header heat shield.
- 15 Check for proper clearance between new exhaust system, number plate, and chassis.

Note: After starting motorcycle, it is normal for new exhaust system to smoke until oil residue burns off.



Fig. 4

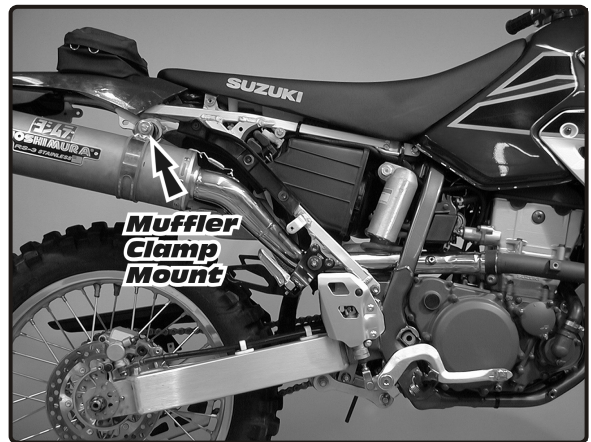

Fig. 5

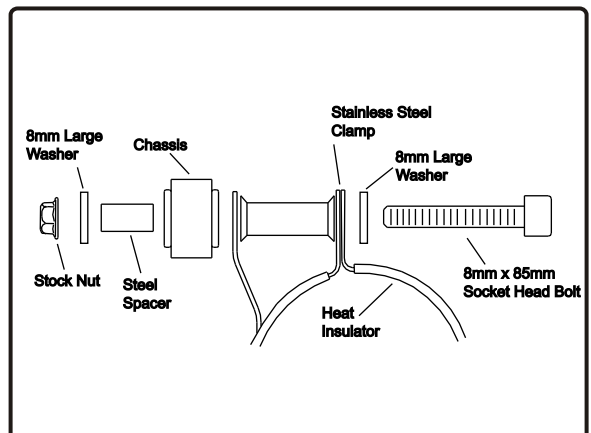
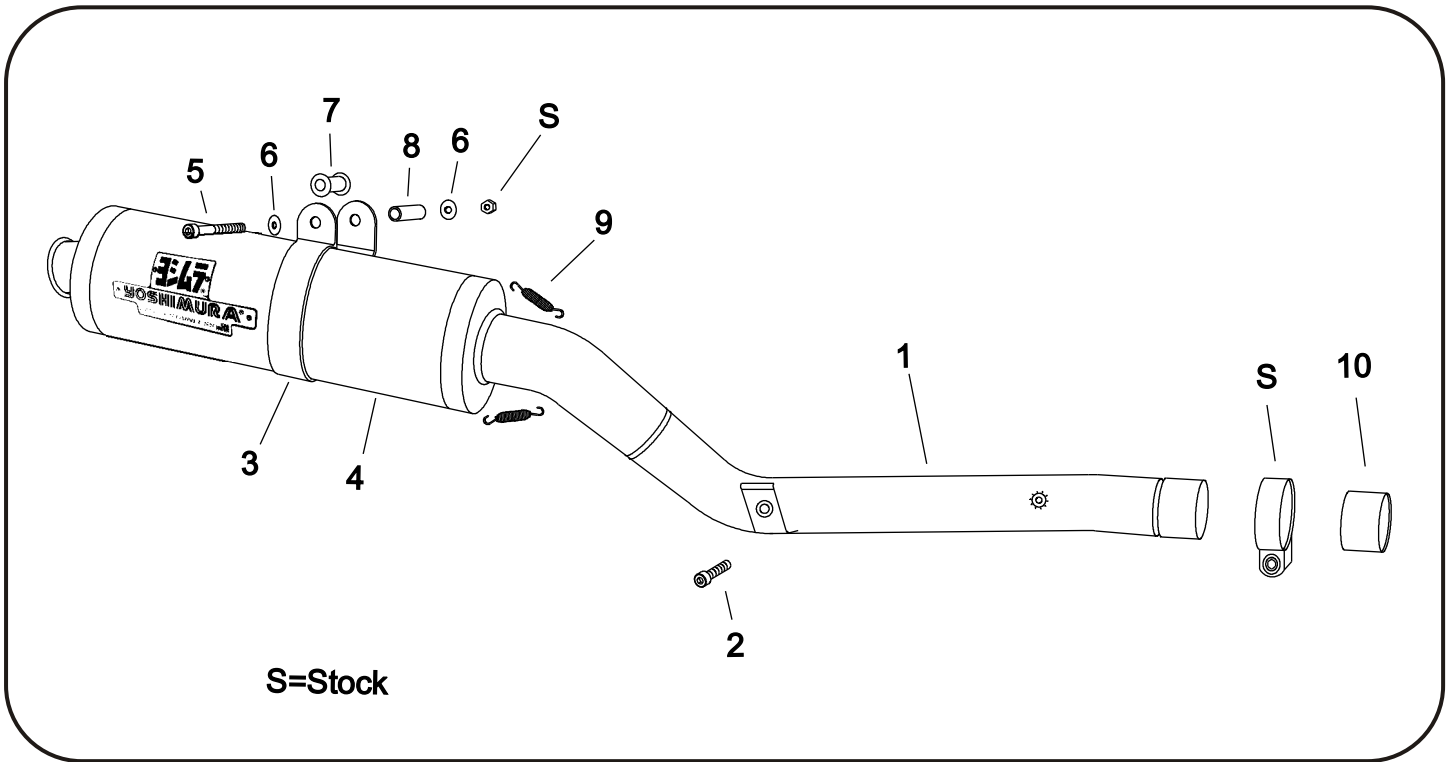

Fig. 6

#2165600-SA



S=Stock

Parts Diagram

NO.	DESCRIPTION	QTY	PART #
1	Yoshimura Slip-On Tail-pipe Stainless Steel	1	2165-142
2	8mm x 25mm Flange Head Bolt	1	M8X25H
3	Stainless Steel Muffler Clamp	1	COS400S8ASD
4	RS-3 Muffler Assembly	1	**
5	8mm x 85mm Socket Head Bolt	1	M8X85
6	8mm Large Washer	2	8MMWASHERL
7	Aluminum Spacer	1	8MMF5
8	Stainless Steel Spacer	1	8X24SP
9	2.6" Medium Exhaust Spring	2	RACE-82MM
10	Exhaust Joint Connector Gasket	1	16-5565
**	Muffler Clamp Heat Insulator	1	HT SHLD-14A
**	Yoshimura Sticker	1	17029

Nuts and Bolts Guide (Actual Size):

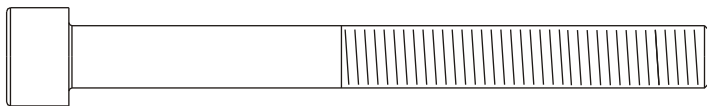

8mm x 85mm
Socket Head Bolt

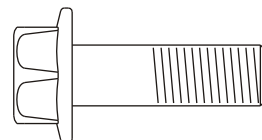

8mm x 25mm
Flange Hex Bolt

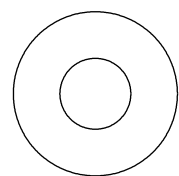

8mm Large Flat Washer



YOSHIMURA

RESEARCH & DEVELOPMENT OF AMERICA, INC.

4555 CARTER COURT, CHINO CALIF. 91710 · (800)634-9166 · (909)628-4722 · FACSIMILE (909)591-2198

www.yoshimura-rd.com

TEC-SA Spark Arrester Cleaning Information

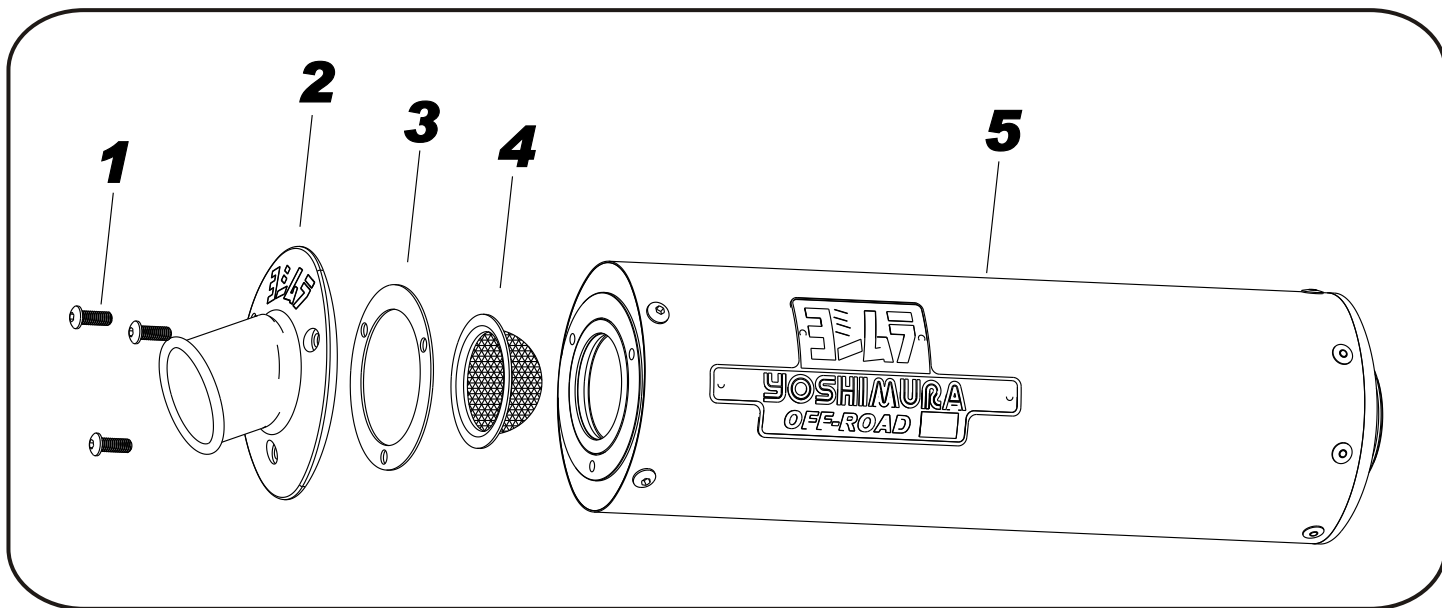

Parts Diagram

Caution: Muffler can be extremely hot. Let muffler cool down before removing spark arrester.

Note: Read through all instructions before beginning disassembly.

Tools Needed:

4mm Allen Key
Wire Brush
Pair of Gloves
Safety Glasses

Cleaning Steps:

1 Using a 4mm Allen key remove the three 6mm x 16mm Button Head Screws located in the muffler end cap. (See Parts Diagram for location)

2 Remove the end cap, gasket and spark arrester from the muffler.

NO.	DESCRIPTION	QTY
1	6 x 1.0mm x 16mm Button Head Screw	3
2	4.0" YRD End Cap, Cover	1
3	T.E.C. End Cap, Gasket	1
4	T.E.C. End Cap, Spark Arrester	1
5	Muffler Assembly	1

3 Using a wire brush remove carbon deposits from spark arrester screen. Once clean inspect the screen for excessive wear or damage, if any is found the spark arrester must be replaced. Cleaning and inspection should be performed after every 60 hours of use.

(Caution: Gloves and Safety Glasses should be worn while cleaning spark arrester.)

4 Re-install spark arrester, gasket, end cap and 6mm x 16mm screws into muffler assembly. Torque screws to 1.0 kg-m (7.3 lb-ft)

(Note: It is recommended that a low strength "Loctite" is used on the screws.)