



# YOSHIMURA

RESEARCH&DEVELOPMENT OF AMERICA, INC.

5420 DANIELS STREET STE A, CHINO CA. 91710 · (800)634-9166 · (909)628-4722 · FACSIMILE (909)591-2198

[www.yoshimura-rd.com](http://www.yoshimura-rd.com)

## **RS4 PERFORMANCE EXHAUST SYSTEM**

**Kawasaki  
2009-2012  
ZX6R**

<b>1464242</b>	RACE ONLY RS4 SLIP-ON SYSTEM WITH CARBON FIBER SLEEVE
<b>1464245</b>	RACE ONLY RS4 SLIP-ON SYSTEM WITH STAINLESS STEEL SLEEVE
<b>1464247</b>	RACE ONLY RS4 SLIP-ON SYSTEM WITH TITANIUM SLEEVE



**THIS PRODUCT IS DESIGNED FOR USE IN CLOSED COURSE RACING AND IS NOT INTENDED FOR HIGHWAY USE.**



Exhaust system and/or components should be installed by a qualified mechanic. If there is any questions contact Yoshimura technical support before attempting installation (800)634-9166 / in CA. (909)628-4722. Yoshimura cannot be held responsible for damage/s incurred from improper installation.

NOTE: IN THE STATE OF CALIFORNIA, IT IS ILLEGAL TO MODIFY THE EMISSION CONTROL SYSTEM, WHICH INCLUDES THE FUEL INJECTION OF ANY VEHICLE.

**Caution:** Exhaust system can be extremely hot. Let motorcycle cool down before beginning installation. Always wear hand and eye protection and take precautionary measures to avoid injury.

**Note:** Read through all instructions before beginning installation.

## Tools Needed:

Metric Socket Set  
Metric Combination Wrench Set  
Metric Allen Wrench Set  
Tamper-Resistant Torx Security Bit  
Torque Wrench  
Small Flat Head Screwdriver

## Installation Steps:

1. Remove stock muffler.
  - Remove heatshield and loosen muffler clamp.
  - Remove muffler mounting bolt.
  - Remove exhaust valve cables from muffler.
  - Remove stock muffler from bike.
  - Reinstall stock heatshield.
2. Install Yoshimura muffler/tailpipe assembly using supplied bolt, stock washer and stock nut. Do not torque at this time. (Note: Yoshimura slip-on system retains stock gasket)
3. Test fit Yoshimura heatshield to match alignment with stock heatshield profile. Adjust muffler as necessary.
4. Torque stock clamp bolt to 12 lb-ft (16 N-m).
5. Torque muffler mounting bolt to 16 lb-ft (21.5 N-m).
6. Install Yoshimura heatshield using supplied bolts.
7. Check for proper clearance between new exhaust system and motorcycle. (i.e. Swing-arm, body work, etc.) If any problem is found, please carefully follow through the installation steps again. If problem still persists, please call Yoshimura tech department at (800)634-9166 / in CA (909)628-4722.

**Note:** After starting motorcycle, it is normal for new exhaust system and muffler to smoke until oil residue burns off.



Fig. 1



Fig. 2

**Yoshimura Servo Motor Bracket Installation**

1. Remove driver seat.
2. Take note of position of exhaust valve servo.
3. Remove cables.
4. Remove exhaust servo nut using *Tamper-Resistant torx bit*.  
*Note: Firmly hold servo pulley in place while loosening servo nut to prevent damage to servo motor.*
5. Remove two phillips screws
6. Install Yoshimura servo motor bracket using stock bolts.  
(Shown in Fig. 2)
7. Install Yoshimura adapter plate on top of the servo pulley using stock bolt. Firmly hold servo pulley in place while tightening servo nut to prevent damage to servo motor.
8. Reinstall seat.

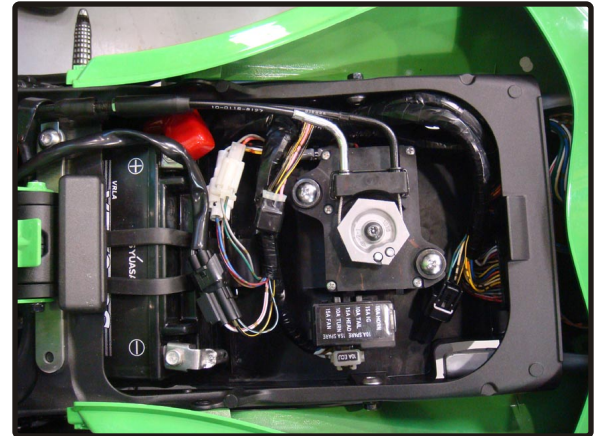
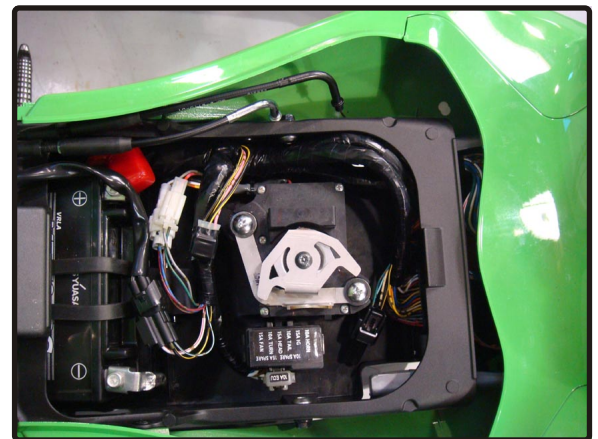
**Fig. 1****Fig. 2**

**146424(2,5,7)**

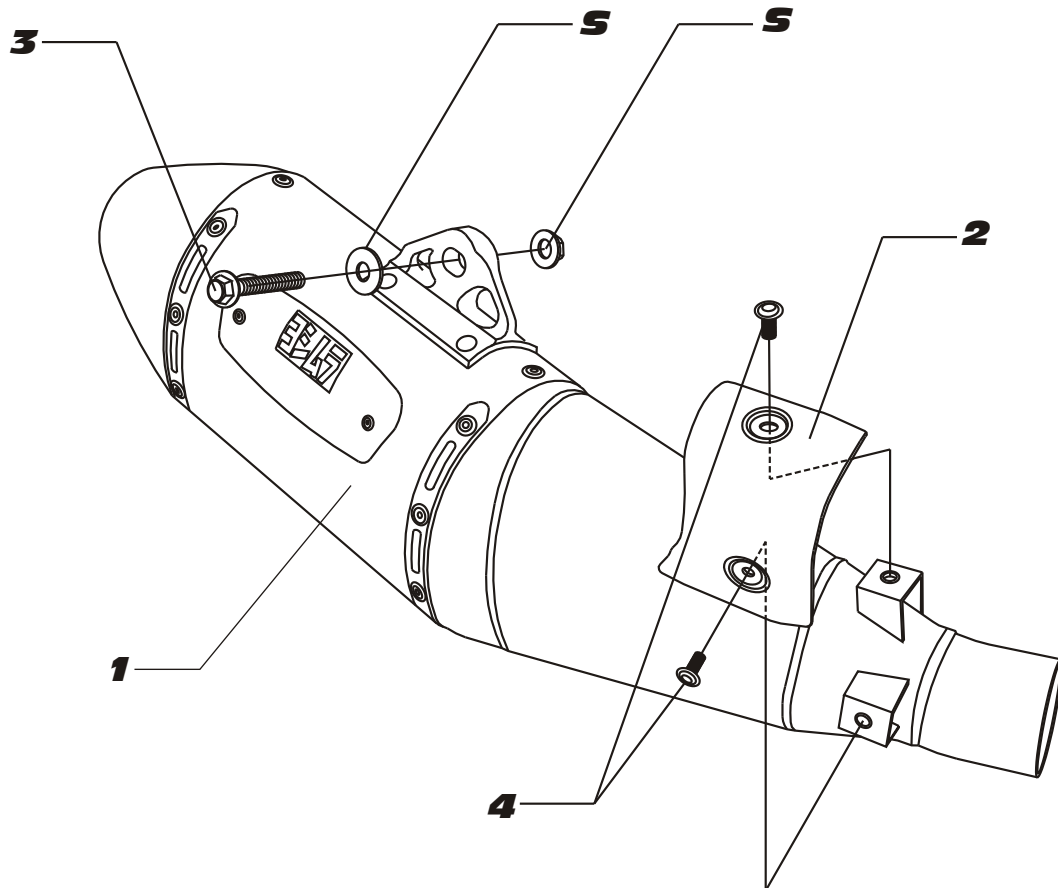

**S=STOCK**

Parts Diagram

<b>NO.</b>	<b>DESCRIPTION</b>	<b>QTY</b>	<b>PART #</b>
1	RS4 Muffler Assembly	1	1464242-RMA
2	RS4 Slip On Heatshield	1	1464-HSA
3	8mm x 45mm Socket Head Hex Bolt	1	M8X45
4	6mm x 8mm Flange Button Head Screw	2	RC116HSB-BK
**	ZX6R Servo Motor Bracket	1	1464-CKRBRKT
**	EVAP Servo Stopper Plate	1	1462-CKRPLT
**	Instructions Manual	1	INST KIT
**	Yoshimura Vinyl Sticker	1	17029