



YOSHIMURA

RESEARCH & DEVELOPMENT OF AMERICA, INC.

5420 DANIELS STREET STE A, CHINO CA., 91786 · (800)634-9166 · (909)628-4722 · FACSIMILE (909)591-2198

www.yoshimura-rd.com

RS-1/RS-3 OVAL PERFORMANCE EXHAUST SYSTEM

KAWASAKI
'03-04
ZX6R/RR

146125(2,5,7)

STAINLESS STEEL RACE ONLY SLIP ON

146135(2,5,7)

STAINLESS STEEL ZYCLONE SLIP ON



THIS PRODUCT IS DESIGNED FOR USE IN CLOSED COURSE RACING AND IS NOT INTENDED FOR HIGHWAY USE.



NOTE: IN THE STATE OF CALIFORNIA, IT IS ILLEGAL TO MODIFY THE EMISSION CONTROL SYSTEM, WHICH INCLUDES THE CARBURETORS OF ANY VEHICLE.

Caution: Exhaust system can be extremely hot. Let motorcycle cool down before beginning installation.

Note: Read through all instructions before beginning installation.

Tools Needed:

11mm & 12mm socket
12mm wrench
Ratchet
13/64" drill bit
Power drill
Safety glasses
Torque wrench

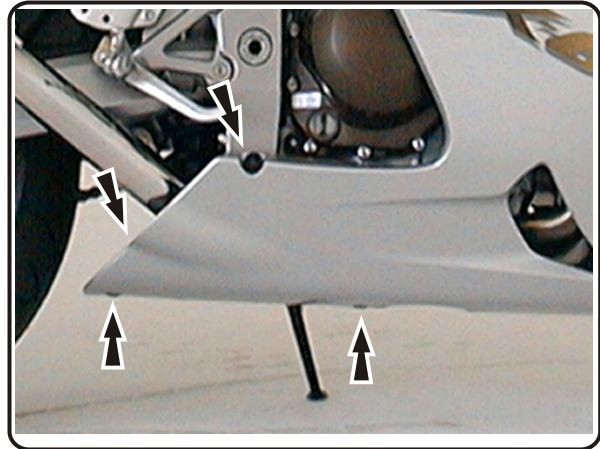

Fig. 1

Installation Steps:

1 Remove lower cowling retaining clips and mounting bolt. (See Fig 1). Carefully wedge a towel or cloth between stock header and lower cowling to obtain sufficient clearance to remove stock tailpipe (See Fig 2)

1 Remove stock muffler and tailpipe assembly.
Note: Stock tailpipe collector gasket may stick to the header - it must be removed for Yoshimura tailpipe to fit over header.

2 Slip 2" stainless steel exhaust clamp over Yoshimura tailpipe and install muffler and tailpipe assembly onto stock header.

3 Apply muffler clamp heat insulator to inside of muffler clamp and slide clamp onto muffler. (Note orientation of clamp in Fig. 1)

4 Mount clamp to stock muffler bracket using stock bolt, washers and nut. (See Fig. 1) Hand tighten bolt only at this point.

5 Standing at the back of the motorcycle, check the orientation of the muffler (the exhaust tip should be pointing down). Note: to adjust fit it may be necessary to rotate either the tailpipe and the muffler independantly until the muffler clamp and muffler are aligned properly.

6 Torque muffler clamp bolt to 2.5 kg-m (18 lb-ft)

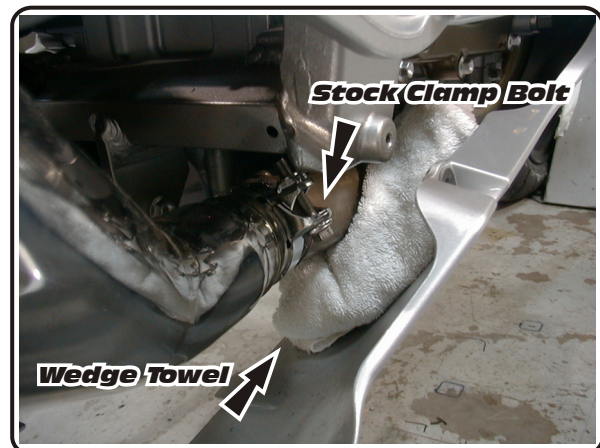

Fig. 2

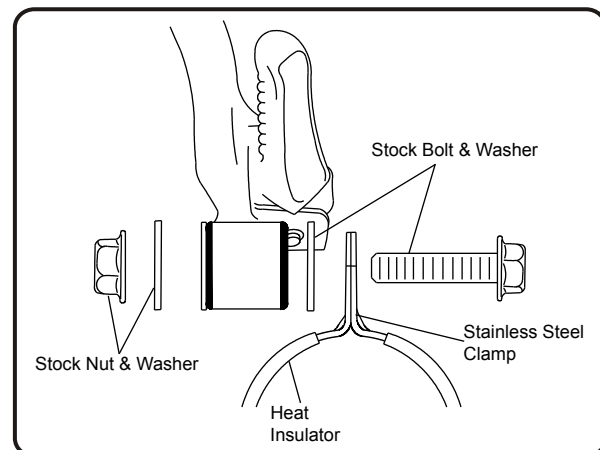

Fig. 3

- 7 Drill 13/64" hole thru end of header at the center of the securing hole in Yoshimura tailpipe. (See Fig.2) (Caution: Always wear eye protection when using any power tool.)
 - 8 Install securing rivet into drilled hole, slide 2" stainless steel exhaust clamp over rivet and torque clamp to 1.25 kg-m (9 lb-ft).
 - 9 It is recommended that the muffler and tailpipe be wiped down with rubbing alcohol to remove oil and fingerprints. This will help prevent tarnishing of the finish after the exhaust is heated up.
 - 10 Check for proper clearance between new exhaust system and swing arm. If any problem is found, please carefully follow through the installation steps again. If problem still persists, please call Yoshimura tech. Dept. at (800)634-9166 / in CA (909) 628-4722
 - 11 Remove towel and re-assemble lower cowling.
 - 12 Check for proper clearance between new exhaust system and cowling.
- NOTE:** After starting motorcycle, it is normal for new exhaust system and muffler to emit smoke until oil residue burns off.

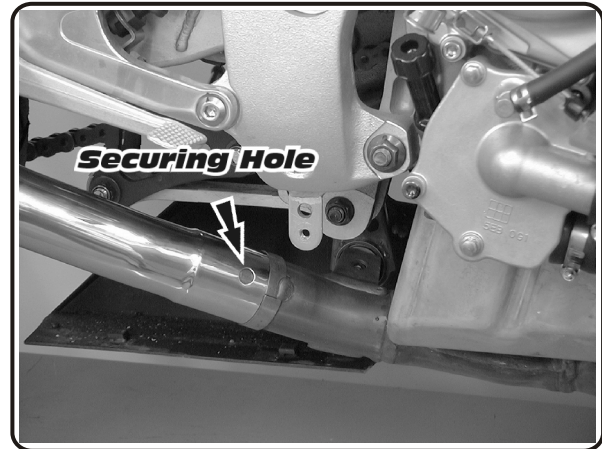
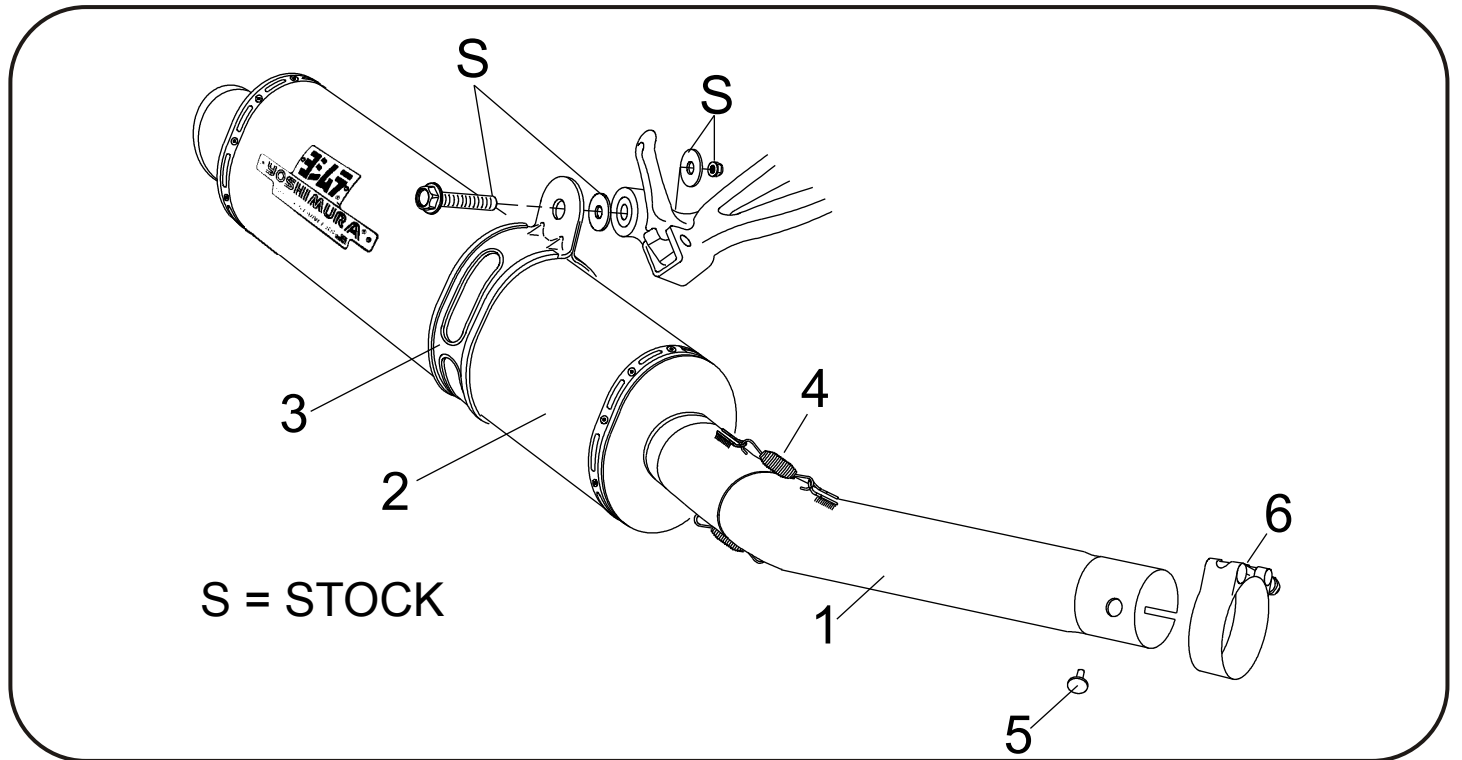

Fig. 4

#146125(2,5,7) - 146135(2,5,7)



Parts Diagram

	DESCRIPTION	QTY	PART #
1	Stainless Steel Race Only Tailpipe	1	1461-235
2	RS-1/RS-3 Oval Muffler Assembly	1	**
3	Stainless Steel Muffler Clamp Stainless Steel or Titanium Sleeve use Carbon Fiber Sleeve use	1	COS450S10BLX COS450S10BL
4	2.3" Race Exhaust Springs	2	RACE-SPS
5	Securing Rivet	1	S-RIVET
6	Stainless Steel Collector Clamp	1	20060
**	Muffler Clamp Heat Insulator	1	HT SHLDTRS
**	Yoshimura Vinyl Sticker	2	17028-BLK