



PERFORMANCE EXHAUST SYSTEM

APPLICATION

YEAR	MODEL
2011-2012	Kawasaki ZX10R

PRODUCT

1418023220	R77D SS Slip-On Exhaust with Carbon Fiber Sleeve; CF Endcap
1418023520	R77D SS Slip-On Exhaust with Stainless Steel Sleeve; CF Endcap
1418023550	R77D SS Slip-On Exhaust with Stainless Steel Sleeve; SS Endcap
1418023720	R77D SS Slip-On Exhaust with Titanium Sleeve; CF Endcap

- ⚠ *This product is designed for use in closed course racing and is not intended for highway use. In the state of California, it is illegal to modify the emission control system, which includes the fuel injection of any vehicle.*
- ⚠ *You must know how to remove and replace your stock exhaust in order to install this product otherwise have it installed by a professional mechanic. Keep all stock parts from your existing system as some components may be necessary to install your new Yoshimura exhaust depending on the application.*
- ⚠ *Read through all instructions before beginning installation. Exhaust system can be extremely hot. Let motorcycle cool down before beginning installation. Always wear hand and eye protection and take precautionary measures to avoid injury.*

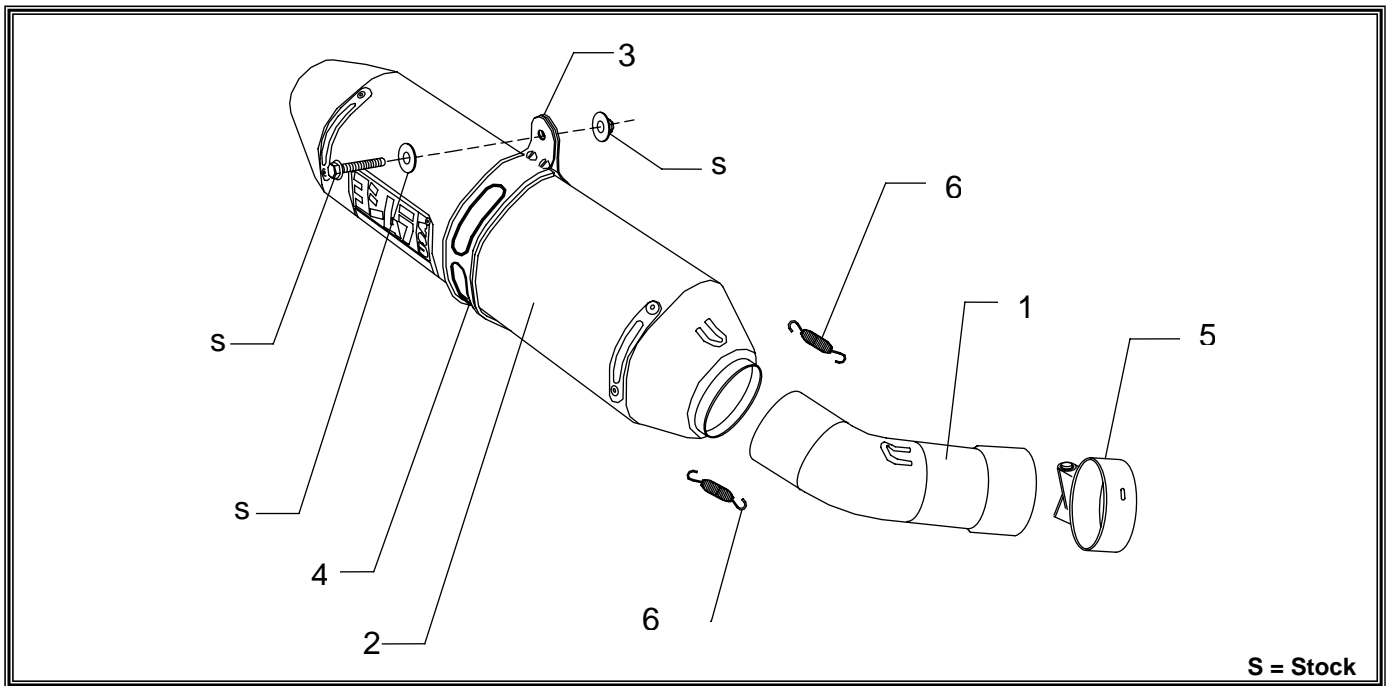

S = Stock

No.	Part #	Description	Qty
1	14180-435	Yoshimura Tailpipe	1
2	CRR77D116W SRR77D116W SRR77D116W-SS TRR77D116W	Yoshimura Muffler CF Sleeve; CF Endcap SS Sleeve; CF Endcap SS Sleeve; SS Endcap Ti Sleeve; CF Endcap	1
3	1121-MPCL 1121-MPCLX	Muffler Clamp CF Sleeve Clamp SS/Ti Sleeve Clamp	1

4	HT SHLDR77	Muffler Clamp Heat Shield	1
5	20067	Exhaust Clamp	1
6	RACE-SPS-1	Med Spring w/ Insulator 2.3"	2
**	17029	Yoshimura Sticker Sht	1
**	ST-200	Spring Puller Tool	1

-TOOLS REQUIRED-

Metric Socket Set

Combination Wrench Set

Torque Wrench

Metric Allen Wrench Set

-REMOVAL-

1. *Removing the stock muffler assembly.*

- a) **Remove stock heat shield by removing the (3) screws.**
- b) **Loosen muffler clamp.**
- c) **While securely holding the muffler, remove the muffler mount bolt and carefully remove stock muffler and muffler clamp.**
- d) **Inspect exhaust gasket ring and replace if necessary. (P/N: 11061-0447)**

-INSTALLATION-

1. *Small parts installation.*

- a) **Install rubber heat shield on muffler clamp. (Note: Some trimming of the rubber heat shield may be necessary.)**
- b) **Install muffler clamp over Yoshimura muffler.**

2. *Installing the Yoshimura Slip-On System.*

- a) **Install Yoshimura exhaust clamp on Yoshimura tailpipe.**
- b) **Insert stock exhaust gasket ring into Yoshimura tailpipe.**
- c) **Install Yoshimura tailpipe over stock midpipe.**
- d) **Using the stock muffler mount bolt, secure the muffler clamp to stock muffler mount location. Do not torque at this time.**
- e) **Tighten and torque exhaust clamp to 10 lb-ft. (13 Nm)**
- f) **Torque muffler mount bolt to 10 lb-ft. (13 Nm)**

3. *Fitment check and Notes.*

- a) **Before starting motorcycle, check for proper clearance between new exhaust system and rear suspension (i.e. tire, swing-arm, brake, rear shock, engine, and etc.) If any problem is found, please carefully follow through the installation steps again. If problem still persists, please call Yoshimura Tech Department at (800) 634-9166 / in CA (909) 628-4722.**
- b) **It is recommended that the muffler and tailpipe be wiped down with rubbing alcohol to remove oil and fingerprints. This will help prevent tarnishing of the finish after the exhaust is heated up.**
- c) **NOTE: After starting motorcycle, it is normal for new exhaust system and muffler to emit smoke until oil residue burns off.**