



YOSHIMURA

RESEARCH & DEVELOPMENT OF AMERICA, INC.

5420 DANIELS STREET STE A, CHINO CA. 91710 · (800)634-9166 · (909)628-4722 · FACSIMILE (909)591-2198

www.yoshimura-rd.com

RS-5 PERFORMANCE EXHAUST SYSTEM

HONDA
2007-2008
CBR600RR

122727(2,5,7)

STAINLESS STEEL SLIP ON SYSTEM WITH CONE CAP



THIS PRODUCT IS DESIGNED FOR USE IN CLOSED COURSE RACING AND IS NOT INTENDED FOR HIGHWAY USE.



NOTE: IN THE STATE OF CALIFORNIA, IT IS ILLEGAL TO MODIFY THE EMISSION CONTROL SYSTEM. WHICH INCLUDES THE FUEL INJECTION OF ANY VEHICLE.

Caution: Exhaust system can be extremely hot. Let motorcycle cool down before beginning installation.

Note: Read through all instructions before beginning installation.

Tools Needed:

Metric Socket Set, Extension, and Ratchet
Metric Combination Wrench Set
Metric Allen Wrench Set
Torque Wrench
Sharp Scissors and Tape

Installation Steps:

1. *Remove rider seat (two bolts under rear corner edges of rider seat) and passenger seat.*
2. *Remove rear seat cowling by removing the four bolts shown in Fig. 1 and pulling the cowling toward the rear of bike and up. Also, remove muffler heatshield bolt (as shown in Fig. 1) at this time.*
3. *Disconnect the three electrical connectors shown in Fig. 2 (brake light, running light, and rear turn signals).*
4. *Remove rear fender, brake light, and rear turn signals from motorcycle (see Fig. 3 and Fig. 4).*
5. *Remove right side rider foot controls (see Fig. 5 for bolt locations).*
6. *Remove right side passenger foot rest (see Fig. 6 for bolt locations).*
7. *Remove stock metal tailpipe heatshield by removing the bolt shown in Fig. 7.*
8. *Remove stock muffler mounting bolts (see Fig. 8 and Fig. 9).*
9. *Loosen exhaust clamp shown in Fig. 10 and remove stock tailpipe, muffler, muffler heatshield.*
10. *Remove bolt in subframe shown in Fig. 11. This will be the new muffler mouning location for the Yoshimura muffler. The stock muffler mounting points on each side of the subframe will not be used.*
11. *Cut out the supplied heatshield template.*
12. *Tape or firmly hold template to adhesive side (not foil side) of heatshield.*
13. *Trace outline of template on heatshield.*
14. *Use scissors to cut heatshield to outline. When cutting, keep excess in one piece - the extra piece will be used later.*
15. *Use rubbing alcohol to clean area where heatshield will be applied.*
16. *Remove adhesive backing and apply to underside of rear fender assembly (see Fig. 12 for BEFORE and AFTER pictures of adhesive foil heatshield installation).*

NOTE: Take a moment to examine how the heatshield lines up with the features of the undertail plastic before you begin.

17. After the heatshield is installed use the scraps to patch or cover any open areas.
18. Slide supplied collector clamp over the inlet of the Yoshimura tailpipe and slide tailpipe onto stock header outlet.
NOTE: No exhaust gasket is used between the stock header and the Yoshimura tailpipe.
19. Install supplied muffler clamp heat insulator to inside of muffler clamp. Slide muffler clamp onto Yoshimura muffler and slide Yoshimura muffler onto Yoshimura tailpipe. Line up muffler clamp ears with new muffler mount location (shown in Fig. 11). Bolt the right side of the clamp to the subframe with the supplied bolt. Slide left side of muffler clamp over the protruding bolt and install the supplied nut.
20. Install exhaust springs between the muffler and the tailpipe.
21. Check alignment of exhaust, then torque supplied collector clamp to 1.25 kg-m (9 lb-ft).
22. Torque muffler clamp bolt and nut to 2.5 kg-m (18 lb-ft).
23. It is recommended that the muffler and tailpipe be wiped down with rubbing alcohol to remove oil and fingerprints. This will help prevent tarnishing of the finish after the exhaust is heated up.
24. Install rubber bumpers into the stock plastic muffler heatshields (see Fig. 13, Fig. 14, and Parts Diagram on the last page).
25. Re-install tailpipe heat shield, rear fender, seat cowling, foot peg, and seat in reverse order of disassembly. Check for proper operation of tail light, brake light, and turn signals before completion.
NOTE: The stock tailpipe heatshield has a rubber grommet on the back of it. Make sure that the rubber grommet is inserted correctly into the tab on the subframe.
26. Check for proper clearance between new exhaust system and motorcycle. (i.e. Swing-arm, body work, etc.) If any problem is found, please carefully follow through the installation steps again. If problem still persists, please call Yoshimura tech department at (800)634-9166 / in CA (909)628-4722.

Note: After starting motorcycle, it is normal for new exhaust system and muffler to smoke until oil residue burns off.



Fig. 1



Fig. 2



Fig. 3



Fig. 4



Fig. 5



Fig. 6



Fig. 7



Fig. 8

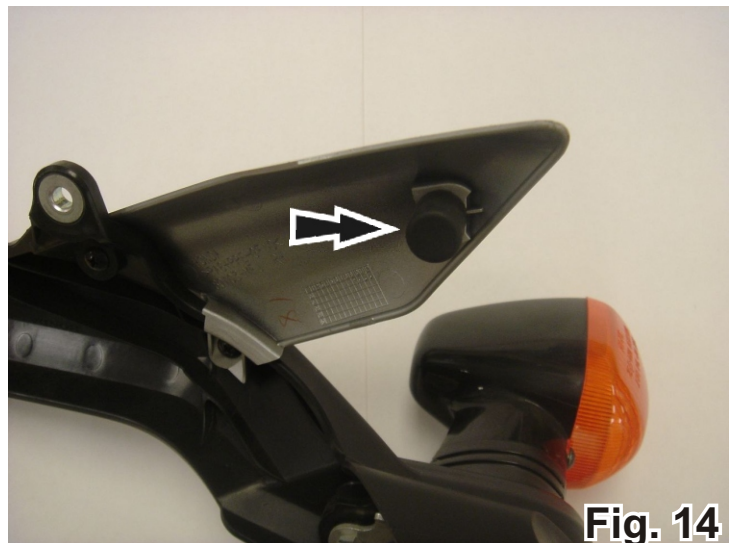
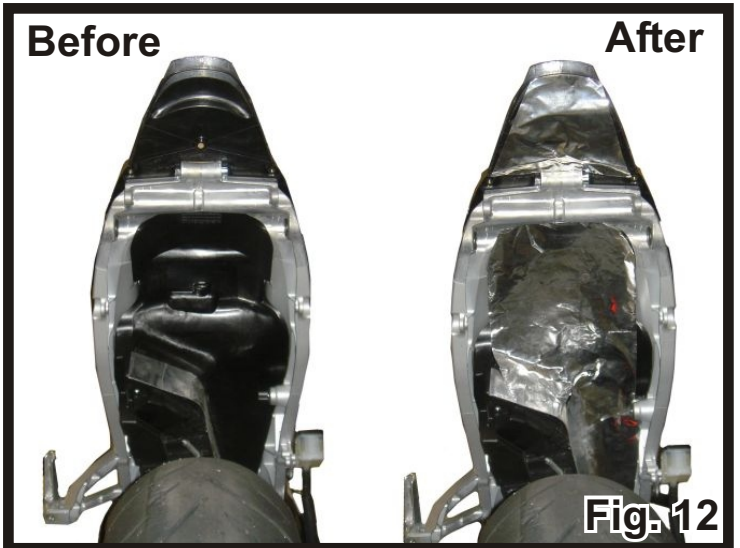
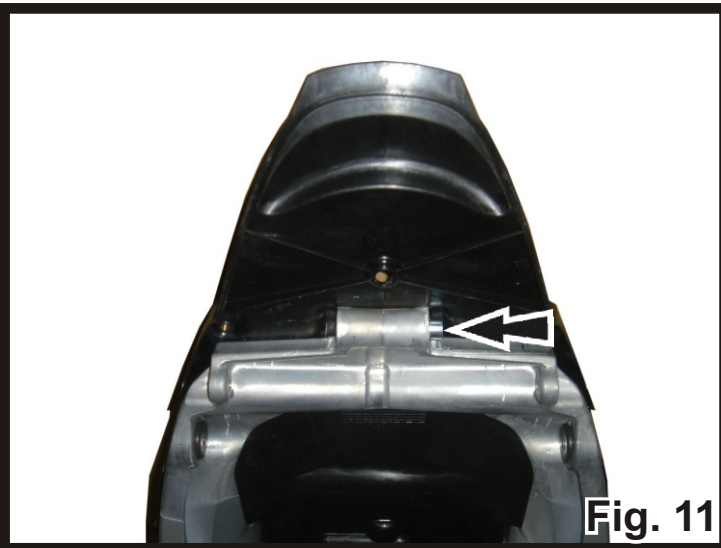
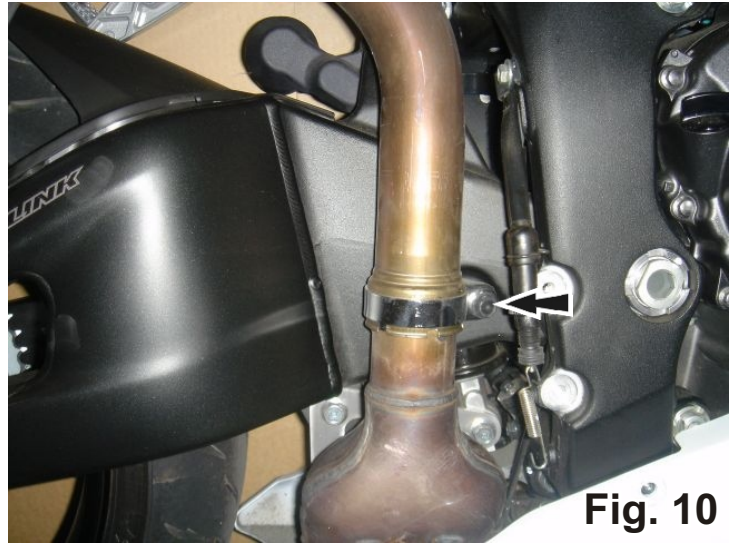

#122727(2,5,7)

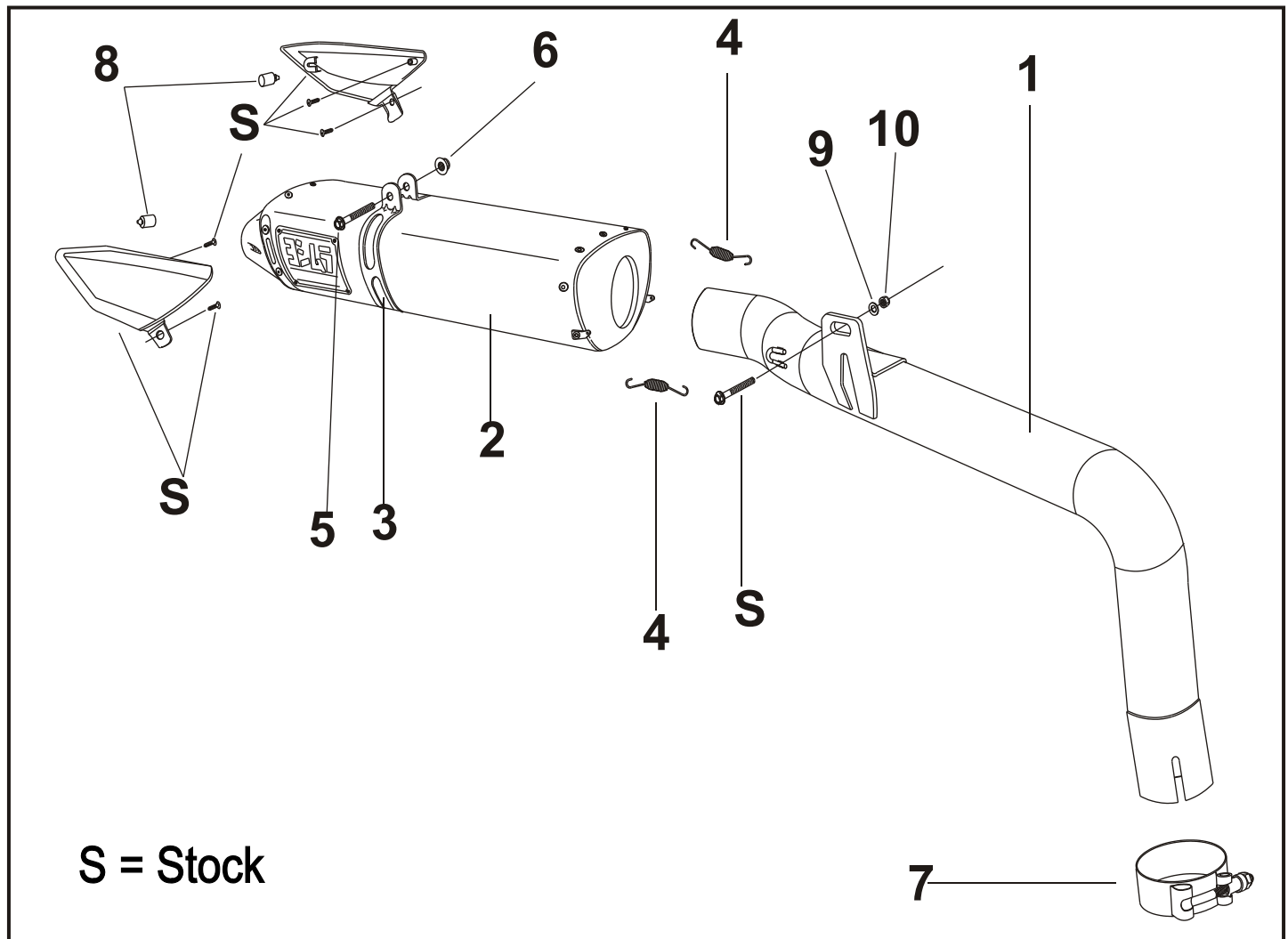

S = Stock

7

Parts Diagram

NO.	DESCRIPTION	QTY	PART #
1	Yoshimura Stainless Steel tailpipe	1	1227-435
2	RS-5 Muffler Assembly	1	
	with Carbon Fiber Sleeve		CRRS5126C
	with Stainless Steel Sleeve		SRRS5126C
	with Titanium Sleeve		TRRS5126C
3	Stainless Steel Muffler Clamp	1	
	Stainless Steel or Titanium Sleeve use		1227-MPCX
	Carbon Fiber Sleeve use		1227-MPC
4	2.5" Exhaust Spring	2	RACE-SPS-1
5	8mm x 65mm Flanged Hex Bolt (Fully Threaded)	1	M8X65H-F
6	8mm Nut	1	8MMNUT
7	Stainless Steel Exhaust Clamp	1	27-62MSH
8	Rubber Bumper	2	4284-034
9	6MM Flat Washer	1	6MMWASHER
10	6MM Nylon Lock Nut	1	6MMLN
**	Adhesive Back Foil Heatshield (8" X 16")	2	1200-00-01
**	Muffler Clamp Heat Insulator	1	HT SHLDTRS
**	Foil Heatshield Template	1	**
**	Yoshimura Vinyl Sticker	1	17029