



# YOSHIMURA

RESEARCH&DEVELOPMENT OF AMERICA, INC.

5420 DANIELS STREET STE A, CHINO CA. 91710 · (800)634-9166 · (909)628-4722 · FACSIMILE (909)591-2198

[www.yoshimura-rd.com](http://www.yoshimura-rd.com)

## **RS-5 PERFORMANCE EXHAUST SYSTEM**

**HONDA**  
**'05-06**  
**CBR600RR**

**122627(2,5,7)**

STAINLESS STEEL SLIP ON SYSTEM WITH CONE CAP



**THIS PRODUCT IS DESIGNED FOR USE IN CLOSED COURSE RACING AND IS NOT INTENDED FOR HIGHWAY USE.**



NOTE: IN THE STATE OF CALIFORNIA, IT IS ILLEGAL TO MODIFY THE EMISSION CONTROL SYSTEM, WHICH INCLUDES THE FUEL INJECTION OF ANY VEHICLE.

**Caution: Exhaust system can be extremely hot. Let motorcycle cool down before beginning installation.**

**Note: Read through all instructions before beginning installation.**

## Tools Needed:

8mm, 10mm, and 12mm sockets  
Ratchet  
10mm and 12mm wrench  
5mm and 8mm Allen wrench  
Torque wrench  
Sharp Scissors

## Installation Steps:

- 1 Remove rider seat (2 bolts under rear edges of seat) and passenger seat.
- 2 Remove right and left side black plastic tank side panels (remove top and side bolts and upper and lower plastic fasteners. Pull front out to unclip and pull toward front of bike to remove) (See Fig. 1).
- 3 Remove seat cowling: Remove 4 bolts (See Fig. 1), pull cowling toward rear of bike and up. Disconnect tail light connector and remove cowling.
- 4 Unbolt black plastic heatshield and right side footpeg assembly. (See Fig. 2) Move footpeg assembly out of the way.
- 5 Remove metal heatshield (right passenger footrest must be removed in order to remove the last bolt).
- 6 Unbolt and remove rear turn signal and fender assembly: rear turn signal connectors (on left rear side) must be disconnected prior to removing fender assembly. (See Fig. 3 & 4)
- 7 Loosen muffler mounting bracket bolts (do not remove). Loosen stock chassis mount bolt (see Fig. 3 for stock chassis mount location).
- 8 Loosen tailpipe to header collector clamp. While supporting muffler/tailpipe assembly (it's heavy) remove chassis mount bolt and muffler support bracket bolts. Remove stock tailpipe and muffler.

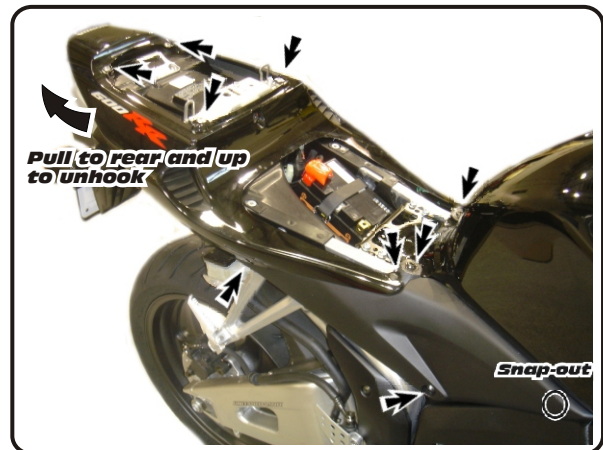

Fig. 1

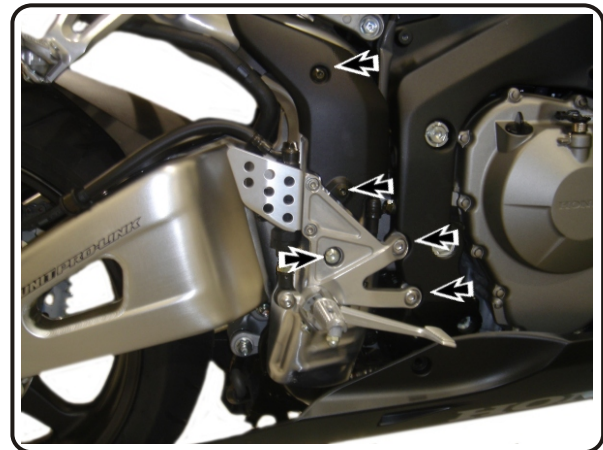

Fig. 2

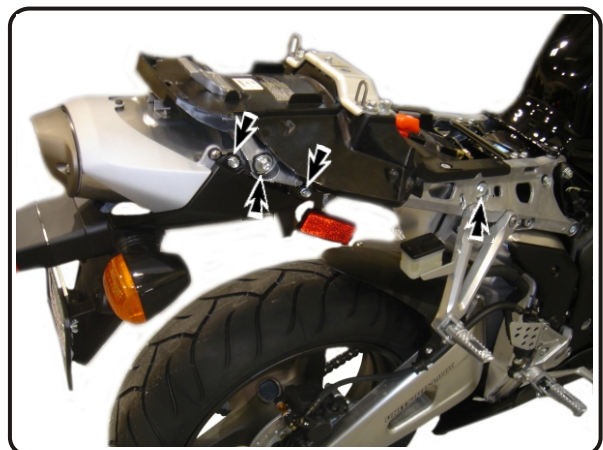

Fig. 3

9 Remove stock heatshield. (Note: Stock heatshield will not be used with Yoshimura system.)

10 Install adhesive heatshield to rear under tail section. (See Page 5 for instructions)

11 Bend tab on stock collector clamp flat so it can be used with Yoshimura tailpipe (See Fig. 5).

12 Slip stock collector clamp over Yoshimura tailpipe and slide tailpipe over stock gasket and stock header. If stock gasket is damaged, replace with new stock gasket. Install stock chassis mount bolt with supplied washer and nut loosely to hold tailpipe in place. Orientation is as follows: Stock bolt, stock washer, tailpipe mounting bracket, supplied washer, supplied nut.

13 Remove bolt pictured in Fig.6. This will be the new muffler clamp mounting point for the Yoshimura muffler. The stock muffler mounting points on each side of the subframe will not be used.

14 Install supplied muffler clamp heat insulator to inside of muffler clamp. Slide muffler clamp onto muffler and line up muffler clamp ears with new muffler mount location. Bolt the right side of the clamp to the subframe with the supplied bolt. Slide left side of muffler clamp over the protruding bolt and install the supplied nut (see Fig. 7).

15 Check alignment of exhaust, then torque stock collector clamp to 1.25 kg-m (9 lb-ft).

16 Torque muffler clamp bolt and nut to 2.5 kg-m (18 lb-ft).

17 Torque chassis mount bolt to 2.5 kg-m (9 lb-ft).

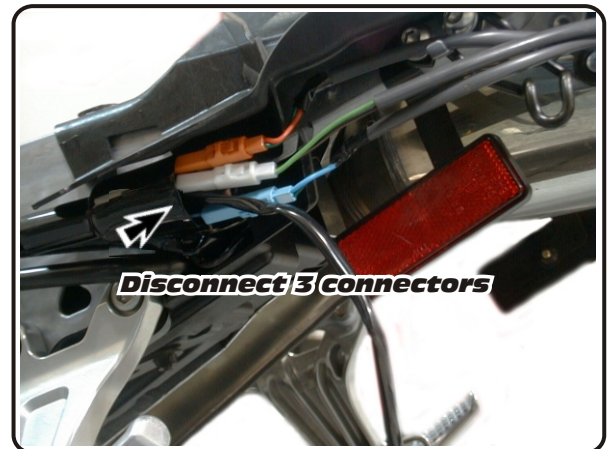
**Fig. 4****Fig. 5****Fig. 6**



**17** It is recommended that the muffler and tailpipe be wiped down with rubbing alcohol to remove oil and fingerprints. This will help prevent tarnishing of the finish after the exhaust is heated up.

**18** Re-install tailpipe heat shield, rear fender, seat cowling, foot peg, and seat in reverse order of disassembly. Check for proper operation of tail light, brake light, and turn signals before completion.

**19** Check for proper clearance between new exhaust system and motorcycle. (i.e. Swing-arm, body work, etc.) If any problem is found, please carefully follow through the installation steps again. If problem still persists, please call Yoshimura tech. dept. at (800)634-9166 / in CA (909)628-4722



Fig. 7

**Note:** After starting motorcycle, it is normal for new exhaust system and muffler to smoke until oil residue burns off.



Fig. 8



Fig. 9

- 1 *Cut out supplied template .*
- 2 *Tape or firmly hold template to adhesive side (not foil side) of heatshield. Make sure template "up" side is correctly oriented.*
- 3 *Trace outline of template on heatshield.*
- 4 *Use scissors to cut heatshield to outline. When cutting keep excess in one piece - the extra piece will be used later.*
- 5 *Use rubbing alcohol to clean area where heatshield will be applied.*
- 6 *Remove adhesive backing and apply to underside of rear fender assembly. Start with the adhesive foil heatshield centered at the rear and work your way forward.*

*Note: Take a moment to examine how the heatshield lines up with the features of the undertail plastic before you begin (See Fig. 8 & Fig. 9 for before and after pictures).*

- 7 *After the heatshield is installed use the scraps to patch or cover any open areas.*

**#122622(2,5,7) / 122627(2,5,7)**

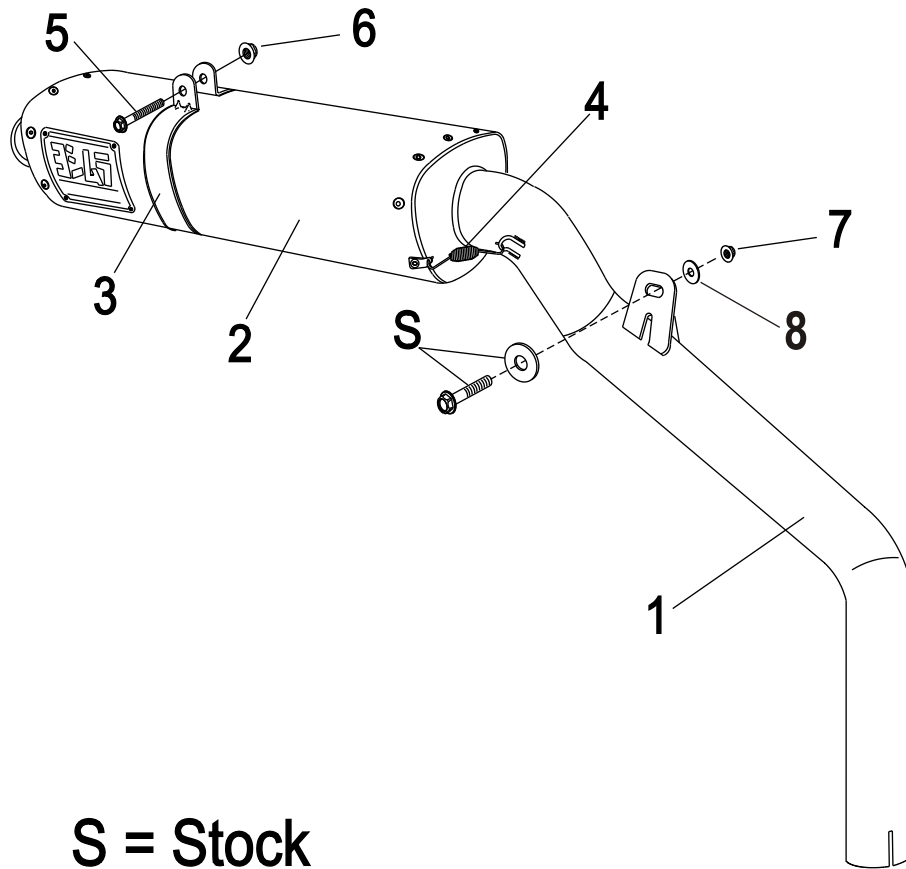

**S = Stock**

Parts Diagram

NO.	DESCRIPTION	QTY	PART #
1	Yoshimura Stainless Steel tailpipe	1	1226-435
2	RS-5 Muffer Assembly	1	**
3	Stainless Steel Muffer Clamp Stainless Steel or Titanium Sleeve use Carbon Fiber Sleeve use	1	CHS502S8ASX CHS502S8AS
4	2.5" Exhaust Spring	2	RACE-SPS-1
5	8mm x 40mm Flanged Hex Bolt	1	M8X40H
6	8mm Nut	1	8MMNUT
7	6mm Nut	1	6MMNUT
8	6mm Washer Large	1	6MMWASHERL
**	Adhesive Back Foil Heatshield (8" X 16")	1	1225-00-01
**	Muffer Clamp Heat Insulator	1	HT SHLD5
**	Yoshimura Vinyl Sticker	1	17029
**	Foil Heatshield Template	1	**

**Nuts and Bolts Guide (Actual Size):**

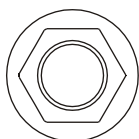

8mm Nut



6mm Nut

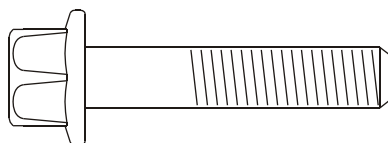

8mm x 40mm Flanged Hex Bolt