



YOSHIMURA

RESEARCH&DEVELOPMENT OF AMERICA, INC.

5420 DANIELS STREET STE A, CHINO CA., 91710 · (800)634-9166 · (909)628-4722 · FACSIMILE (909)591-2198

www.yoshimura-rd.com

R77 PERFORMANCE EXHAUST SYSTEM

BMW
2012-2014
S1000RR

1520100220 R77 Stainless Steel Full-System Exhaust with Carbon Fiber Sleeve



THIS PRODUCT IS DESIGNED FOR USE IN CLOSED COURSE RACING AND IS NOT INTENDED FOR HIGHWAY USE.



NOTE: IN THE STATE OF CALIFORNIA, IT IS ILLEGAL TO MODIFY THE EMISSION CONTROL SYSTEM, WHICH INCLUDES THE FUEL INJECTION OF ANY VEHICLE. IMAGES REPRESENT PRODUCT WITH OPTIONAL YOSHIMURA ACCESSORIES.

Caution: Exhaust system can be extremely hot. Let motorcycle cool down before beginning installation. Always wear hand and eye protection and take precautionary measures to avoid injury.

Note: Read through all instructions before beginning installation.

Tools Needed:

- 3/8" ratchet and extension
- Combination Wrench Set
- Torque wrench
- Torx Bit Set

Installation Steps:

- 1 Remove Stock Exhaust System
 - a. Loosen stock muffler clamp behind heat shield.
 - b. Remove stock muffler mount bolt connected to rearset (Fig. 1).
 - c. Slide muffler off underbelly silencer outlet.
 - d. Remove left and right lower fairings (Fig. 2).
 - e. Disconnect and remove exhaust valve cables from stock exhaust header and servo motors. Note that there are three valves; two valves at the front of the header and one at the rear near the header outlet. Slacken the locknuts holding the cables in place and remove from both the servo motor end and also the exhaust valve end. Servo motors **MUST** remain connected to the vehicles electronic system in order to prevent a malfunction indicator light from being displayed on the gaugeset.
 - f. Remove radiator support bracket (Fig. 3).
 - g. Disconnect the (2) O2 sensors on header.
 - h. Loosen header flange nuts.
 - i. Loosen header bracket bolt beneath frame.
 - j. Remove header assembly from vehicle.

NOTE: Inspect condition of stock header gaskets. Stock header gaskets are to be re-used with the Yoshimura exhaust system. If damaged, replacement parts can be found at your local BMW dealership using PN: 18 21 7 717 848.

- 2 Passenger Footpeg Option

This Yoshimura exhaust system allows the option of using the included aluminum muffler hanger bracket which replaces the stock passenger footpeg, or to utilize the stock passenger footpeg in conjunction with the included bracket adapter. Please follow the instructions below for each option:

- A. Yoshimura aluminum muffler hanger:
 - a. Remove right and left passenger footpegs and brackets by removing 2 bolts each securing brackets to the subframe.
 - b. Install Yoshimura aluminum muffler hanger onto right side of subframe and secure using supplied hardware (as shown in Parts Diagram on last page).
Tighten to 20.5 ft-lbs (28 N-m).
- B. Stock Passenger Footpeg:
 - a. Remove cotter pin below footpeg to remove footpeg pin (Fig. 4).
 - b. Carefully remove stock footpeg and bracket from hanger, being sure not to lose the detent ball and spring during removal.



Fig. 1



Fig. 2



Fig. 3

2 cont.

- c. Install supplied hex head bolt through footpeg. See Fig. 5.
- d. Install supplied footpeg bracket behind footpeg using the supplied nut. See diagram for proper orientation.
- e. Re-install footpeg using the opposite steps of removal.

Note: Optional heat shield installation instructions on last page.

3 Install Yoshimura Exhaust System

- a. Install Yoshimura flanges and manifold onto exhaust ports. Note orientation of flanges as shown in Fig. 6. Install springs onto flanges when installing onto exhaust ports. Do not tighten at this time.
- b. Reinstall radiator support bracket. Tighten to 6 ft-lbs (8 N-m).
- c. Insert rubber grommet and aluminum insert into Yoshimura tailpipe bracket as shown in the Parts Diagram. Insert Yoshimura header tubes into Yoshimura tailpipe.
- d. Remove O2 sensors from stock header and install onto Yoshimura header. Torque to 18.5 ft-lbs (25 N-m).
Note: Optional O2 sensor plugs is included if aftermarket O2 or Air/Fuel ratio sensor is used, or to remove stock O2 sensors.
- e. Insert Yoshimura header tubes into manifolds starting from one side, one by one. Verify that all header tubes are fully seated into manifolds, then install exhaust springs for each header tube. Connect O2 sensors to stock connectors. Route wiring as stock wiring was routed.
- f. Secure tailpipe bracket to frame mount using supplied washer and bolt. Install muffler springs between header outlets and tailpipe. Do not tighten mounting bracket bolt at this time.
- g. Slide Yoshimura muffler onto tailpipe. Install muffler clamp heat shield onto muffler clamp. Slide muffler clamp over muffler. Install muffler springs between Yoshimura tailpipe and muffler.
- h. Insert supplied muffler mount bolt through muffler clamp, supplied hardware as shown in the Parts Diagram, and the aluminum muffler hanger (rear passenger footpeg if used, See Fig 5) and secure muffler clamp to muffler hanger bracket.
- i. Tighten all fasteners from front to rear while checking clearances and fitment.
- j. Tighten header nuts to 10 ft-lbs (14 N-m).
- k. Tighten tailpipe bracket mount bolt to 15 ft-lbs (20 N-m).
- l. Tighten muffler bracket mounting bolts to 20.5 ft-lbs (28 N-m).
- m. Reinstall left and right lower fairings.

4 It is recommended that the muffler and heat shields be wiped down with rubbing alcohol or other alcohol based cleanser to remove oil and fingerprints. This will help prevent tarnishing of the finish after the exhaust is heated up.

Check for proper clearance between new exhaust system and motorcycle (i.e. swing-arm, body work, etc.). If any problem is found, please carefully follow through the installation steps again. If problem still persists, please call Yoshimura technical department at (800)634-9166 / in CA (909)628-4722.

NOTE: After starting motorcycle, it is normal for a new exhaust system and muffler to smoke until oil residue burns off.

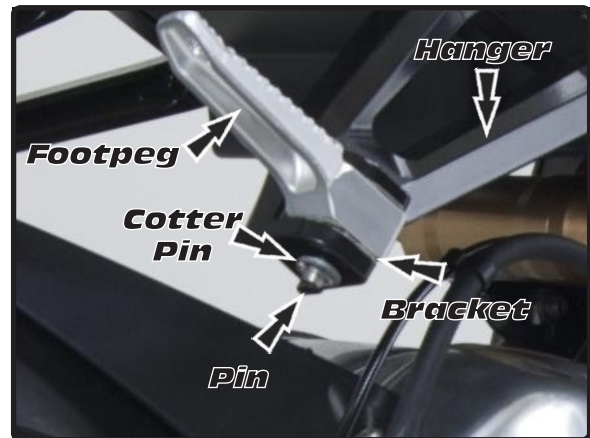

Fig. 4



Fig. 5

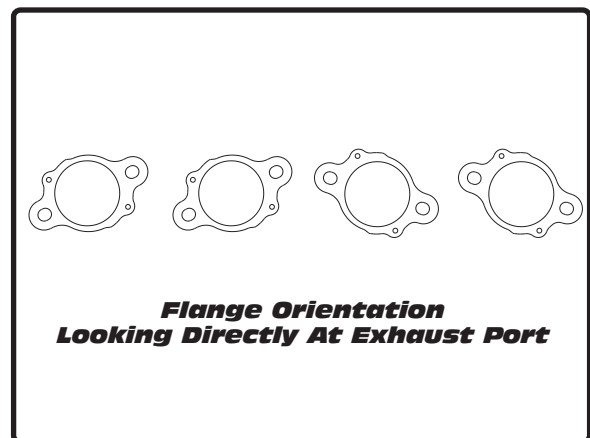
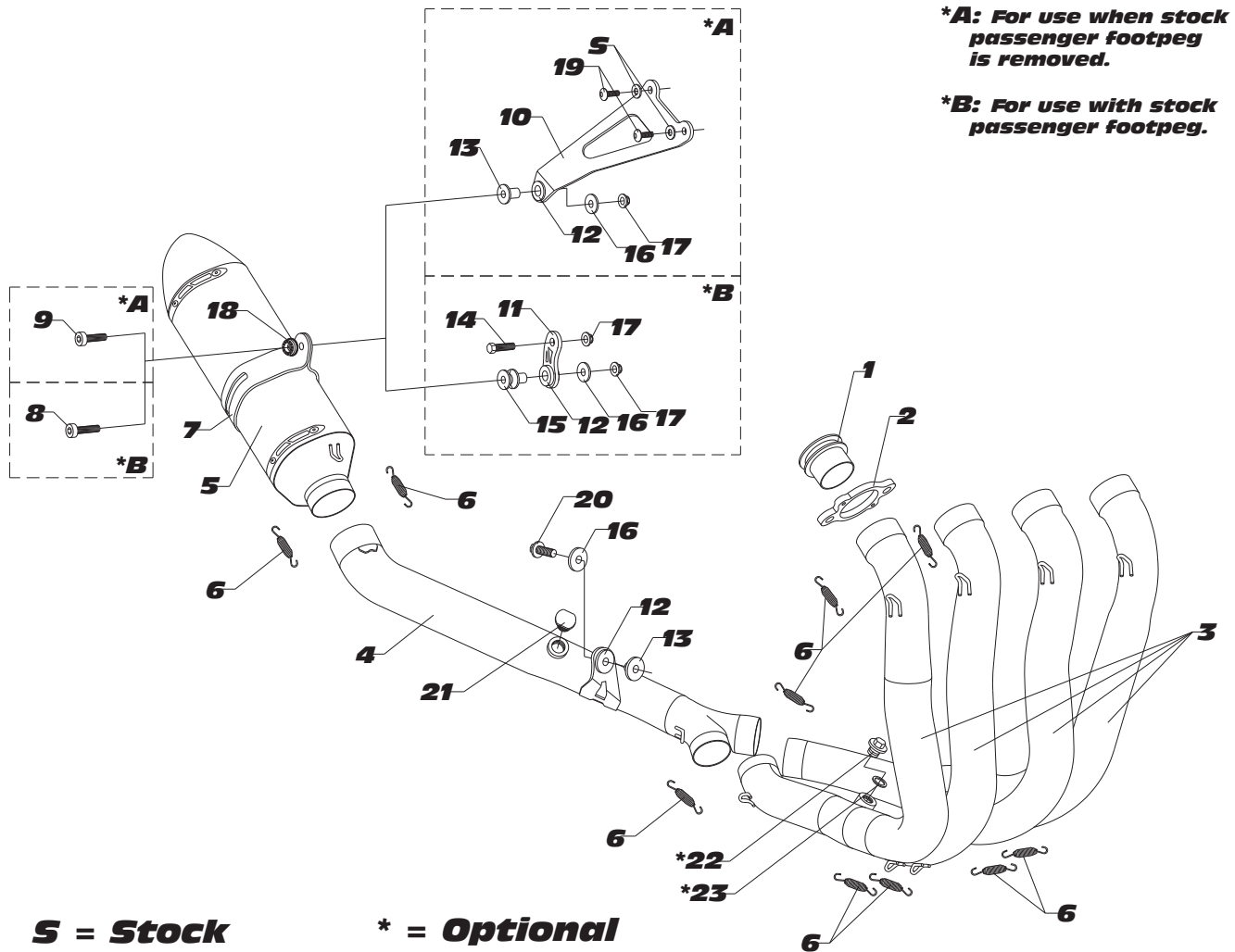

Fig. 6

PN: 1520100220



Parts Diagram

NO.	DESCRIPTION	QTY	PART #
1	Stainless Manifold	4	1520SDM-00
2	Stainless Flange	4	1520SDR-00
3	Stainless Steel Header	1	15201-404
4	Stainless Steel Tailpipe	1	15201-419
5	Yoshimura R77 Carbon Muffler	1	CRR77F126W
6	Medium Exhaust Spring	16	RACE-SPS-1
7	Muffler Clamp	1	1520-MPCR
8	8mm x 50mm Socket Bolt	1	M8X50
9	8mm X 35mm Socket Bolt	1	M8X35
10	Aluminum Muffler Hanger Bracket	1	1520ABF-B
11	Stock Footpeg Bracket	1	1520-SHB-00
12	Rubber Grommet	2	Z1022
13	Aluminum Insert	2	ALS-003
14	8mm x 30mm Hex Head Bolt	1	M8X30HX
15	Aluminum Spacer Insert	1	ALS-010
16	8mm Large Washer	2	8MMWASHERL
17	8mm Flange Nut	2	8MMNUT
18	Countersink Washer	1	M8ALCSW-00

NO.	DESCRIPTION	QTY	PART #
19	8mm x 20mm Button Head Screw	2	M8X20BHS
20	8mm x 25mm Flange Bolt	1	M8X25H
21	O2 Sensor Plug (M18)	1	M18X13PLG
22	O2 Sensor Plug (M12) -optional-	2	M12X8H
23	M12 Copper Washer -optional-	2	12MMCW
24	Aluminum Heatshield	1	15201-HS-00
25	Heatshield Bracket 1	1	15201-HS-BRK
26	Heatshield Bracket 2	1	1520-HS-BRK2-00
27	6mm x 10mm Button Head Screw	1	M6X10BHS
28	8mm x 12mm Flanged Hex Bolt	1	M8X12H
29	Heat Shield Bolt	5	RC116HSB-BK
**	8mm Stainless Steel Washer	1	8MMWASHER-SS
**	Muffler Clamp Heat Shield	1	HT SHLDR77
**	Low Volume Insert Kit	1	INS-04-K
**	Yoshimura Vinyl Sticker	1	17029
**	Spring Tool	1	ST-200
**	Instruction Manual	1	INST KIT

Heatshield Installation:

Optional heatshield is included in the Yoshimura exhaust system kit for customers who are utilizing the OEM bodywork. This heatshield is NOT designed for use with aftermarket bodywork or bodywork which has been modified for track, race, or aesthetic purposes.

1. Install Yoshimura Heatshield bracket according to the diagram. The large Y bracket mounts to the stock muffler chassis mount using the provided M8X12H bolt and the small bracket mounts behind the right fairing using the stock fairing screw.
2. Remove rear lower cowling plastic clip securing left and right lower cowlings near the oil pan.
3. Install heat shield bracket (PN: 1520-HS-BRK2-00) to heat shield using supplied hardware and secure loosely.
4. Install heat shield onto heatshield bracket and secure with supplied bolts. Check alignment between heat shield and left and right lower cowl panels. Tighten all heat shield bolts.

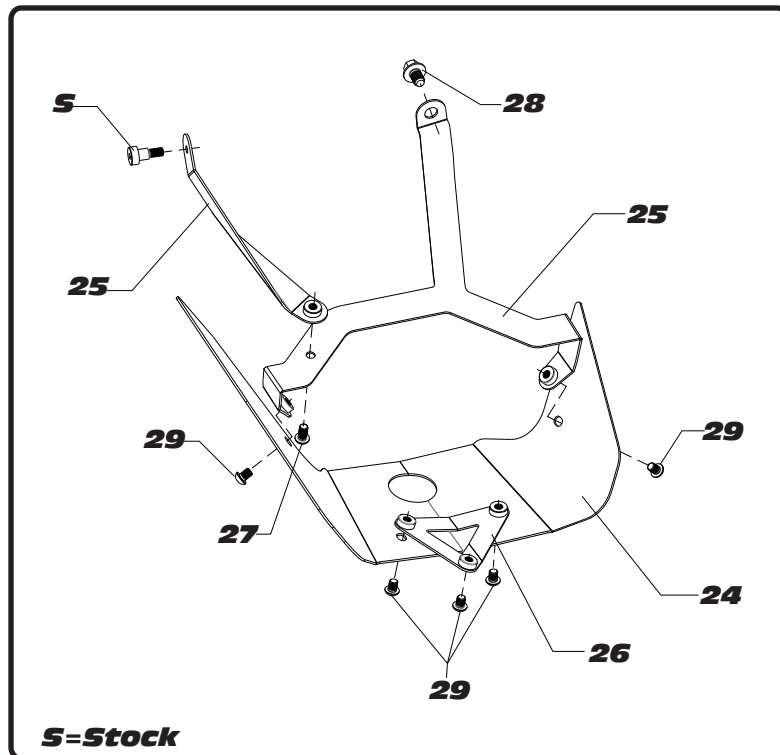

Parts Diagram