



PERFORMANCE EXHAUST SYSTEM

APPLICATION

YEAR	MODEL
2013	Kawasaki ZX6R

PRODUCT

1464120220	R77 SS Slip-On Exhaust with Carbon Fiber Sleeve; Carbon Fiber Endcap
1464120520	R77 SS Slip-On Exhaust with Stainless Steel Sleeve; Carbon Fiber Endcap

- This product is designed for use in closed course racing and is not intended for highway use. In the state of California, it is illegal to modify the emission control system, which includes the fuel injection of any vehicle.
- You must know how to remove and replace your stock exhaust in order to install this product otherwise have it installed by a professional mechanic. Keep all stock parts from your existing system as some components may be necessary to install your new Yoshimura exhaust depending on the application.
- Read through all instructions before beginning installation. Exhaust system can be extremely hot. Let motorcycle cool down before beginning installation. Always wear hand and eye protection and take precautionary measures to avoid injury.

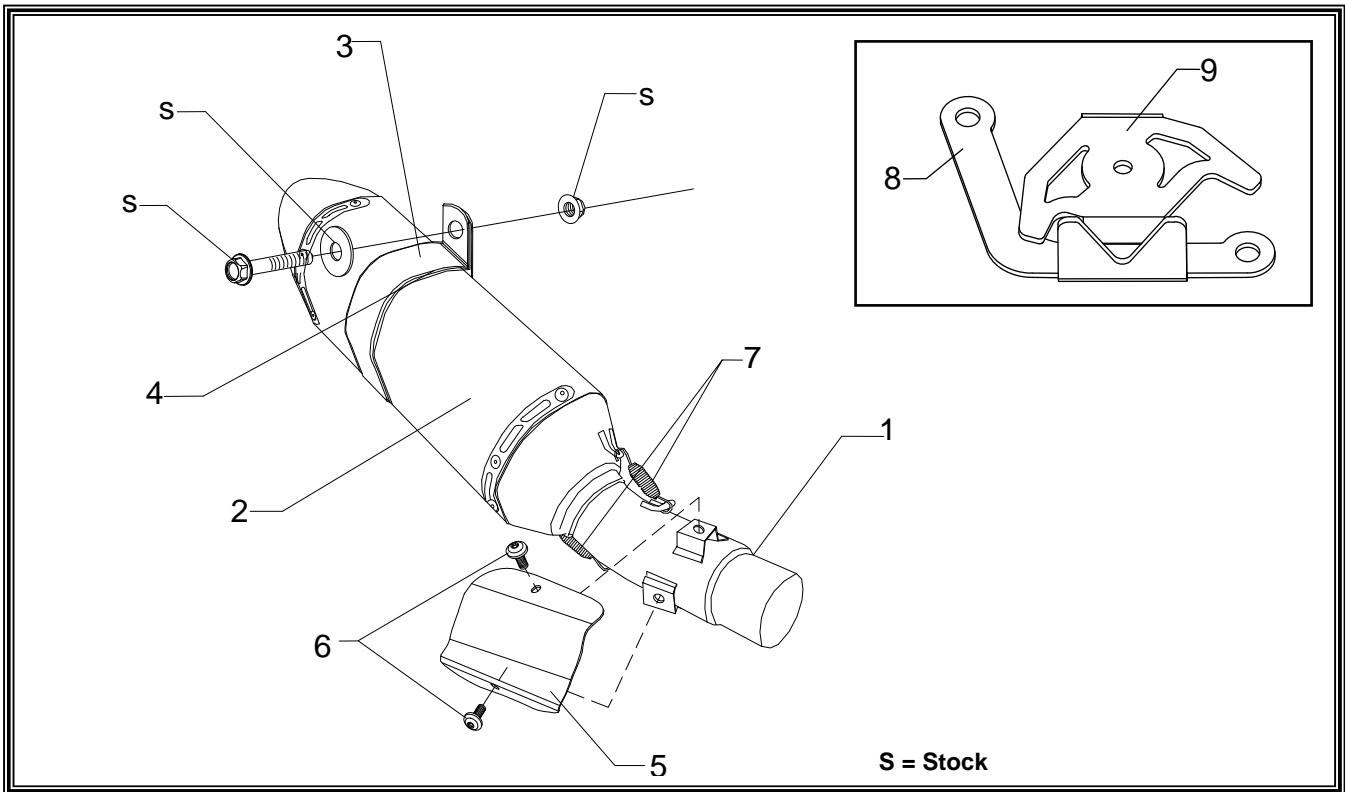

No.	Part #	Description	Qty
1	1464-435	Yoshimura Tailpipe	1
2	CRR77126W SRR77126W	Yoshimura Muffler Carbon Fiber Sleeve; CF Endcap Stainless Steel Sleeve; CF Endcap	1
3	1121-MPCR 1121-MPCRX	Yoshimura Muffler Clamp Carbon Fiber Sleeve Stainless Steel Sleeve	1
4	HT SHLDR77	Muffler Clamp Heatshield	1
5	14641-R77HS	Yoshimura Heatshield	1
6	RC116HSB-BK	6mm x 8mm Flanged Button Head Screw	2
7	RACE-82MM	Exhaust Spring	2
8	1464-CKRBRKT	ZX6R Servo Motor Bracket	1
9	1462-CKRPLT	ZX6R Servo Motor Stopper Plate	1
**	INS-04-K	Low Volume Sound Insert	1
**	ST-200	Spring Puller Tool	1
**	17029	Yoshimura Sticker Sheet	1

-TOOLS REQUIRED-

*Metric Socket Set • Combination Wrench Set • Torque Wrench • Metric Allen Wrench Set
Screwdriver • Tamper Proof Torx Bit*

-REMOVAL-

1. Removing the stock muffler.

- a) Remove the heatshield and loosen exhaust clamp.**
- b) Remove exhaust valve cables from muffler.**
- c) Remove muffler mounting bolt.**
- d) Remove stock muffler assembly.**

-INSTALLATION-

1. Installing Yoshimura Servo Motor Bracket.

- a) Remove rider seat as per Factory Service or Owners manual.**
- b) Take note of exhaust valve servo position.**
- c) Carefully remove exhaust valve cables.**
- d) Remove exhaust servo bolt using tamper proof torx bit.**

Note: Firmly hold servo pulley in place while loosening servo nut to prevent damage to servo motor.

- e) Remove the (2) phillips screws.**
- f) Install Yoshimura servo motor bracket using the stock screws.**



- g) Install Yoshimura adapter plate on top of the servo pulley using the stock torx bolt. Firmly hold servo pulley in place while tightening servo bolt to prevent damage to servo motor. See diagram for proper orientation.**
- h) Re-install rider seat using the reverse steps of removal.**

2. Installing Yoshimura muffler assembly.

- a) Install rubber heatshield onto Yoshimura muffler clamp.**
- b) Slide muffler clamp over Yoshimura muffler.**
- c) Install Yoshimura muffler tailpipe assembly using stock hardware. Do not torque at this time.**
Note: The Yoshimura slip-on exhaust system reuses the stock exhaust gasket. Inspect and replace if necessary.
- d) Install Yoshimura heatshield using supplied bolts. See diagram for proper orientation. Adjust tailpipe and/or muffler as necessary.**
Note: Removal of muffler springs may be necessary in order to rotate the muffler and tailpipe independently. Re-install muffler springs after desired alignment is achieved.
- e) Torque stock exhaust clamp to 12 lb-ft (16 Nm).**
- f) Torque muffler mounting bolt to 16 lb-ft (21.5 Nm).**

3. Fitment check and Notes.

- a) Before starting motorcycle, check for proper clearance between new exhaust system and rear suspension (i.e. tire, swing-arm, brake, rear shock, engine, and etc.) If any problem is found, please carefully follow through the installation steps again. If problem still persists, please call Yoshimura Tech Department at (800) 634-9166 / in CA (909) 628-4722.**
- b) It is recommended that the muffler and tailpipe be wiped down with rubbing alcohol to remove oil and fingerprints. This will help prevent tarnishing of the finish after the exhaust is heated up.**
- c) NOTE: After starting motorcycle, it is normal for new exhaust system and muffler to emit smoke until oil residue burns off.**