



YOSHIMURA

RESEARCH&DEVELOPMENT OF AMERICA, INC.

5420 DANIELS STREET STE A, CHINO CA., 91710 · (800)634-9166 · (909)628-4722 · FACSIMILE (909)591-2198

www.yoshimura-rd.com

PERFORMANCE EXHAUST SYSTEM

Yamaha Bolt

131700K500

RSCV Stainless Steel Full-System



THIS PRODUCT IS DESIGNED FOR USE IN CLOSED COURSE RACING AND IS NOT INTENDED FOR ANY OTHER USE.



You must know how to remove and replace your stock exhaust in order to install this product otherwise have it installed by a professional mechanic. Keep all stock parts from your existing system as some components may be necessary to install your new Yoshimura exhaust depending on the application. Read through all instructions before beginning installation. Exhaust system can be extremely hot. Let motorcycle cool down before beginning installation. Always wear hand and eye protection and take precautionary measures to avoid injury.



NOTE: IN THE STATE OF CALIFORNIA, IT IS ILLEGAL TO MODIFY THE EMISSION CONTROL SYSTEM, WHICH INCLUDES THE CARBURETORS OF ANY VEHICLE.

Assembly Diagram

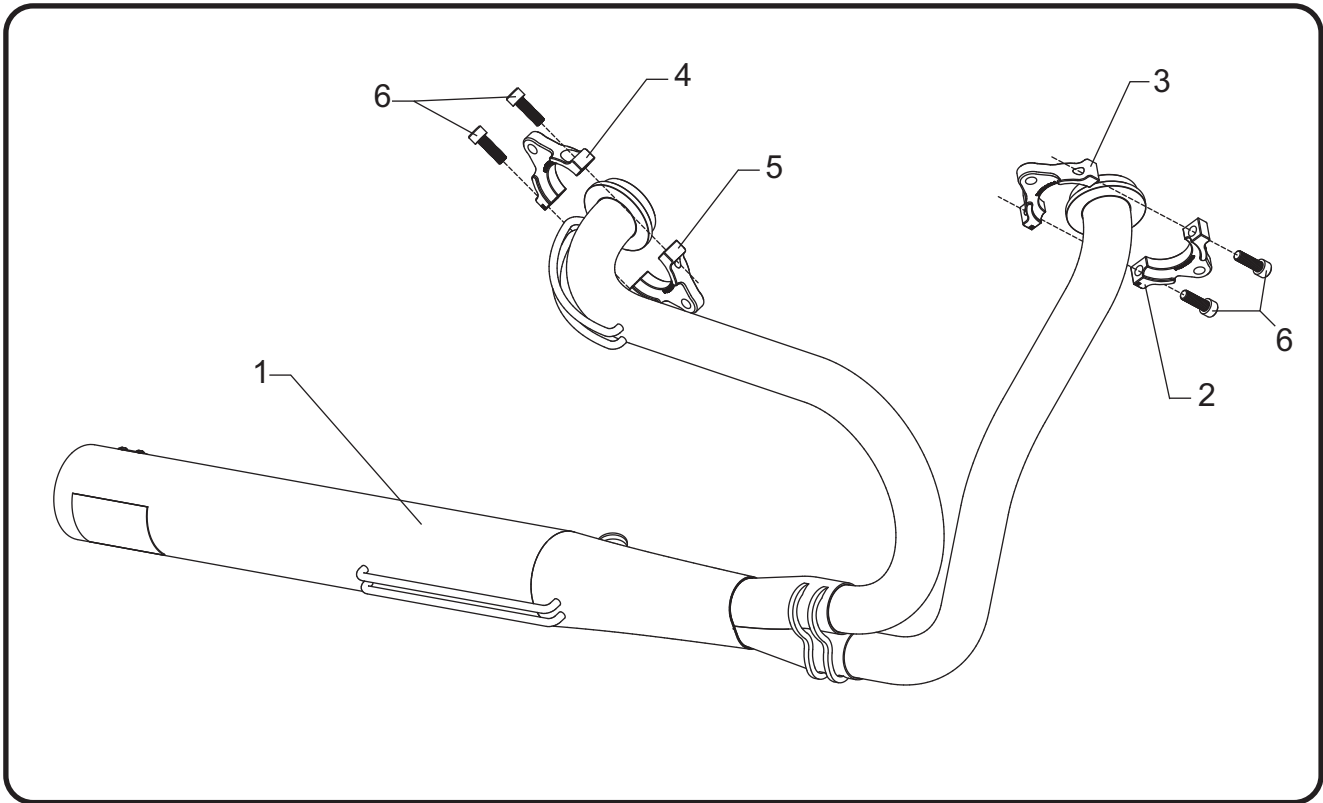

No.	Item	Description	Qty.
1	13170-401	Yoshimura Stainless Steel Full-System	1
2	13170-ADR-F1	Front Flange 1	1
3	13170-ADR-F2	Front Flange 2	1
4	13170-ADR-R1	Rear Flange 1	1
5	13170-ADR-R2	Rear Flange 2	1
6	M8X25	8mm x 25mm Socket Head Cap Screw	4
**	10MMFNUT	10mm Flange Nut	1
**	17029	Sticker Kit Sheet	1

** Not shown in diagram.

Removal

1. Loosen the exhaust clamp at the muffler to header connection.
2. Remove O2 sensor from the stock muffler.
3. While securely supporting the muffler, remove the two muffler mount bolts. Carefully remove the stock muffler assembly by sliding toward the rear of the motorcycle.
4. Remove the front header heatshield to allow for more room to maneuver the header around the frame.
5. While securely supporting the header, remove the front header nuts and rear header bolts. Carefully remove header making sure not to scratch the frame.

Note¹: Cover the frame with a shop rag or mask using tape to prevent scratching the frame during removal.

Note²: Exhaust port gaskets will be re-used with the Yoshimura full-system. Inspect gaskets and replace if necessary.

Installation

1. Install 13170-ADR-F1/2 front header flange (No. 2,3) onto front header leg using M8X25 bolts (No. 6).

Note¹: Hand tighten M8X25 bolts (No. 6).

Note²: Push flange against manifold and torque M8X25 bolt (No. 6) to 16 Nm (1.6 kg-m, 12 ft-lb).

Note³: Front flanges are different from the rear flanges and are marked accordingly. Improper pairing or installation of flanges can damage the motorcycle and potentially injure the rider during operation.

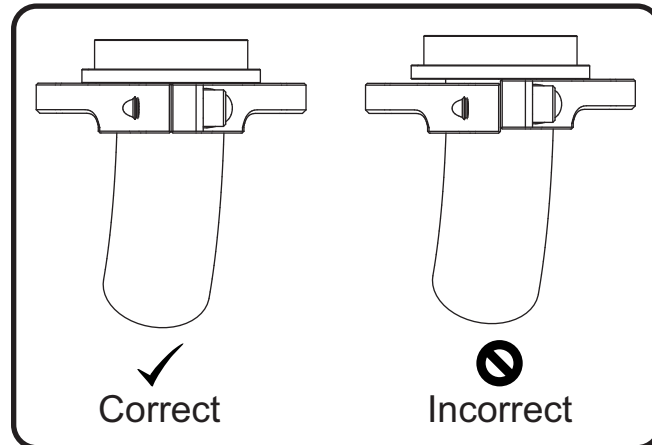
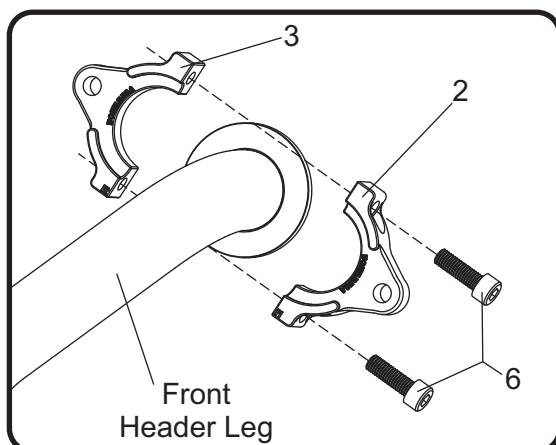

2. Install 13170-ADR-R1/2 rear header flange (No. 4,5) onto rear header leg using M8X25 bolts (No. 6).

Note¹: Hand tighten M8X25 bolts (No. 6).

Note²: Push flange against manifold and torque M8X25 bolt (No. 6) to 16 Nm (1.6 kg-m, 12 ft-lb).

Note³: Rear flanges are different from the front flanges and are marked accordingly. Improper pairing or installation of flanges can damage the motorcycle and potentially injure the rider during operation.

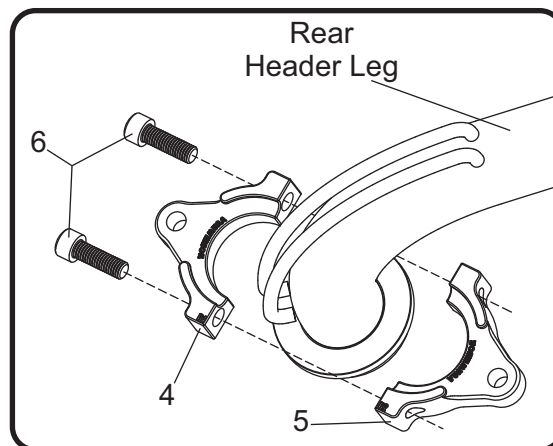

3. Install 13170-401 header (No. 1) using the stock flange nuts and flange bolts. Do not torque at this time. See diagram for proper orientation of flanges.
4. Secure muffler to muffler mount using the stock bolt and provided 10MMFNUT. Torque nut to 35 Nm (3.5 kg-m, 25 ft-lb).

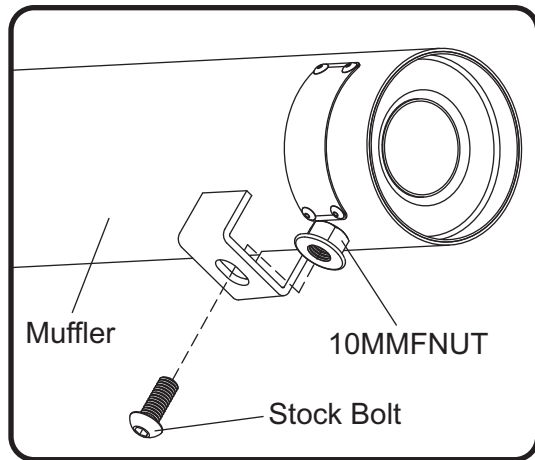

5. Install stock O2 sensor and torque to 45 Nm (4.5 kg-m, 33 ft-lb).
6. Torque stock flange nuts and flange bolts to 20 Nm (2.0 kg-m, 14 ft-lb).
7. Before starting vehicle, check for proper clearance between new exhaust system and rear suspension (i.e. tire, control arm, brakes, rear shock, and etc.) If any problem is found, please carefully follow through the installation steps again. If problem still persists, please call Yoshimura Tech Department at (800) 634-9166 / in CA (909) 628-4722.
8. It is recommended that the muffler and tailpipe be wiped down with rubbing alcohol to remove oil and fingerprints. This will help prevent tarnishing of the finish after the exhaust is heated up.

Note: After starting vehicle, it is normal for new exhaust system and muffler to emit smoke until oil residue burns off.