



# RACE SERIES

**Qualified Manufacturer Declared "Modified Part"**

**APPLICATION**

|            |  |
|------------|--|
| YEAR       | MODEL  |
| 2007-2016  | Suzuki V-Strom 650   |
| PRODUCT    |  |
| 1162040220 | R77 SS 3/4 System with Carbon Fiber Sleeve; Carbon Fiber Endcap    |
| 1162040520 | R77 SS 3/4 System with Stainless Steel Sleeve; Carbon Fiber Endcap |

**FOR CLOSED COURSE COMPETITION ONLY; NOT INTENDED FOR STREET USE**

|   |  |
|---|--|
| ! | This product is designed for use in closed course racing and is not intended for highway use. In the state of California, it is illegal to modify the emission control system, which includes the fuel injection of any vehicle.   |
| ! | You must know how to remove and replace your stock exhaust in order to install this product otherwise have it installed by a professional mechanic. Keep all stock parts from your existing system as some components may be necessary to install your new Yoshimura exhaust depending on the application. |
| ! | Read through all instructions before beginning installation. <u>Exhaust system can be extremely hot.</u> Let motorcycle cool down before beginning installation. Always wear hand and eye protection and take precautionary measures to avoid injury.  |

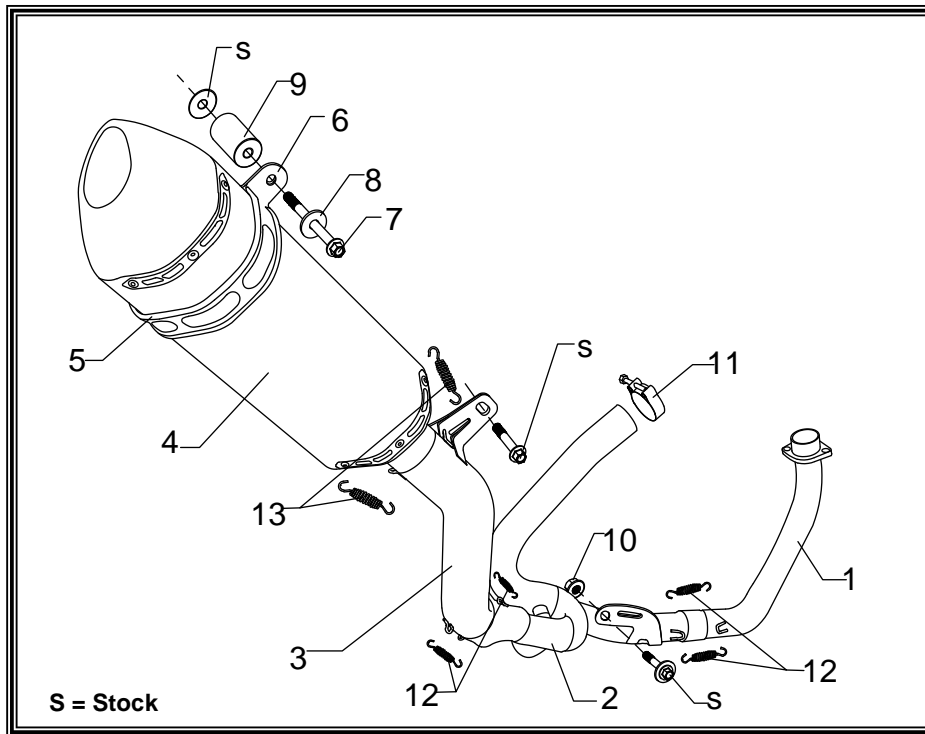

| No. | Part #                           | Description  | Qty |
|-----|----------------------------------|--|-----|
| 1   | 11620-401                        | Yoshimura Header   | 1   |
| 2   | 11620-415                        | Yoshimura Midpipe  | 1   |
| 3   | 11620-419                        | Yoshimura Tailpipe   | 1   |
| 4   | 1162040220-RMA<br>1162040520-RMA | Yoshimura Muffler<br>Carbon Fiber Sleeve<br>Stainless Steel Sleeve | 1   |
| 5   | HT SHLDR77                       | Muffler Clamp Heatshield   | 1   |
| 6   | 1121-MPCR<br>1121-MPCR-X         | Muffler Clamp for<br>CF Sleeve<br>SS Sleeve                        | 1   |
| 7   | M8X90H                           | 8mm x 90mm Flanged Hex Head Bolt                                   | 1   |
| 8   | 8MMWASHERL                       | 8mm Large Washer   | 1   |
| 9   | ALS-036                          | Aluminum Spacer  | 1   |
| 10  | 8MMNUT                           | 8mm Flange Nut   | 1   |
| 11  | 22055                            | Exhaust Clamp  | 1   |
| 12  | RACE-SPS-1                       | Medium Spring  | 4   |
| 13  | RACE-SPX-1                       | Short Spring   | 2   |
| **  | OXYBA12X125SS                    | O2 Bung Adaptor  | 1   |
| **  | M18X13PLG                        | O2 Bung Plug   | 1   |
| **  | ST-200                           | Spring Puller Tool   | 1   |
| **  | 17029                            | Yoshimura Sticker Sheet  | 1   |
| **  | INS-04-K                         | Low Volume Sound Insert  | 1   |

**-TOOLS REQUIRED-**

*Metric Socket Set • Combination Wrench Set • Torque Wrench • Metric Allen Wrench Set*

**-REMOVAL-**

1. **Remove the right passenger foot peg.**
2. **Remove the two piece muffler heatshield.**
3. **Remove O2 sensor from stock muffler.**  
*Note: '07-'11 models do not have O2 sensor.*
4. **Loosen both front and rear header exhaust clamps.**
5. **Remove chassis mount bolt.**
6. **Remove the muffler mount bolt closest to the rear of vehicle.**
7. **Loosen the muffler mount bolt closest to the front. This will allow the stock muffler assembly to swing forward just enough to aid in removal of the front header.**
8. **Remove the (2) front header bolts.**
9. **Carefully remove front header by pulling toward the front of the vehicle.**
10. **Remove the previously loosened muffler mount bolt. Carefully remove stock muffler assembly by sliding off of rear header.**

**-INSTALLATION-**

1. **Slide provided exhaust clamp onto rear header midpipe inlet.**
2. **Install Yoshimura midpipe by sliding onto rear header.**
3. **Slide Yoshimura front header into midpipe and install header using the stock header bolts.**  
*Note: The stock exhaust port gasket will be used with the Yoshimura 3/4 system. Inspect and replace if necessary.*
4. **Secure midpipe to chassis mount using the stock bolt. See diagram for proper orientation. Do not torque chassis mount bolt at this time.**  
*Note: Secure midpipe chassis mount to the inside of the frame.*
5. **Install rubber heatshield onto Yoshimura muffler clamp.**
6. **Slide muffler clamp over Yoshimura muffler/tailpipe assembly.**
7. **Using the hardware provided in the kit, install Yoshimura muffler/tailpipe assembly as shown in the parts diagram.**  
*Note: Aluminum spacer mounts on the outside of the stock muffler mount.*
8. **Install exhaust springs according to the parts diagram.**
9. **Install O2 sensor bung adaptor to Yoshimura tailpipe and install stock O2 sensor. Install the provided O2 bung plug if not equipped with an O2 sensor.**
10. **Torque muffler mount bolt to factory specification.**
11. **Torque tailpipe mount bolt to factory specification.**
12. **Torque chassis mount bolt to factory specification.**
13. **Torque stock rear header exhaust clamp to factory specification.**
14. **Torque front header bolts to factory specification.**
15. **Before starting motorcycle, check for proper clearance between new exhaust system and rear suspension (i.e. tire, swing-arm, brake, rear shock, engine, and etc.) If any problem is found, please carefully follow through the installation steps again.**
16. **It is recommended that the muffler and tailpipe be wiped down with rubbing alcohol to remove oil and fingerprints. This will help prevent tarnishing of the finish after the exhaust is heated up.**  
*Note: After starting motorcycle, it is normal for new exhaust system and muffler to emit smoke until oil residue burns off.*