



## INSTALLATION GUIDE

# 2005-CURRENT TOYOTA TACOMA



**PRODUCT CODES:  
502 & 507**



*Revised: May 5, 2009*

## TOOLS NEEDED

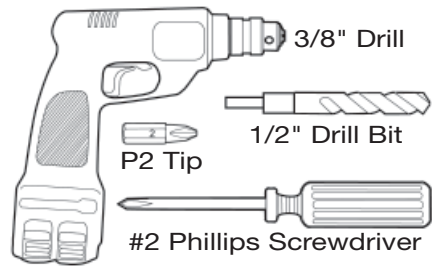

## COMPONENTS INCLUDED

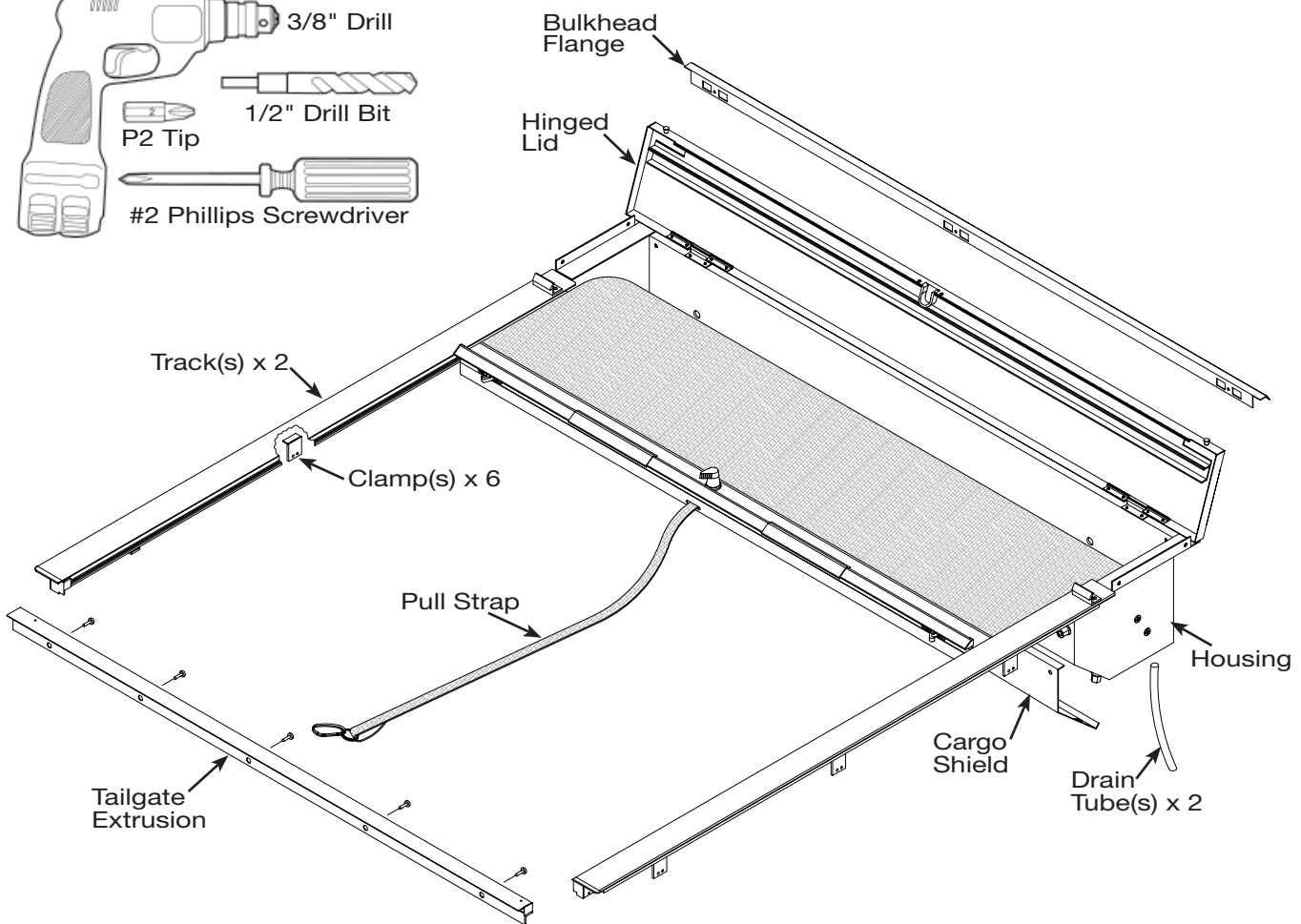

### **STEP 1: INSTALL BULKHEAD ADAPTER**

- A.** Remove an end cap from the bulkhead "C" channel (**Photo 1**) and insert three of the threaded blocks (**Photo 2**).

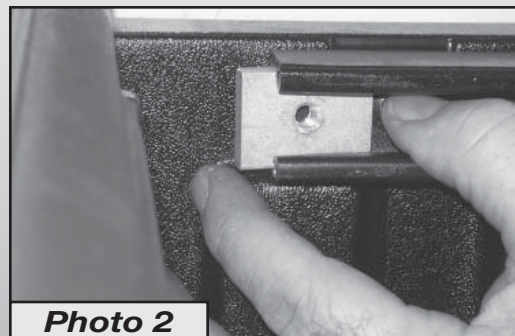
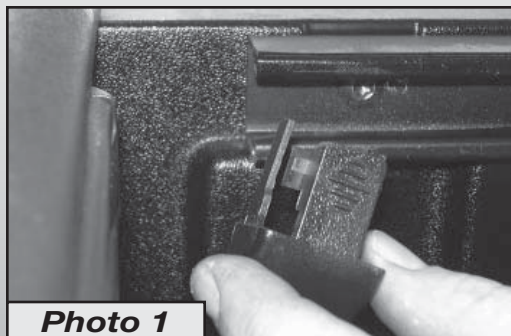

## STEP 1: INSTALL BULKHEAD ADAPTER (CONTINUED)

- B.** Lay Bulkhead Adapter Flange onto the bulkhead (**Photo 3**) and position the threaded

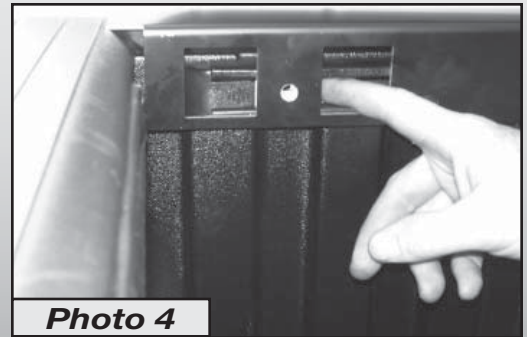
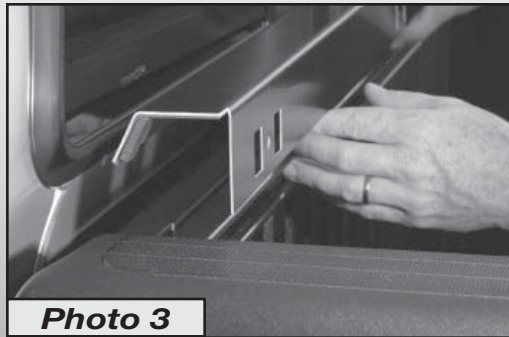

blocks between the knockouts so the holes line up (**Photo 4**). Use ¼ - 20 x 1" counter-sunk screws to secure the Adapter Flange to the bulkhead.

## STEP 2: INSTALL HOUSING

- A.** Place the Housing Assembly onto the bed rails (**Photo 5**). Center it between the rails and leave about ½"



of space between the bulkhead and the back of the Housing. **Do not fasten the Housing in place.**

- B.** Lift the Lid on the Housing and lean it against the cab (**Photo 6**). Place a rag between the Lid and cab to prevent scratches.

## STEP 3: INSTALL TRACKS

- A.** Making sure to leave the Pull Strap connected to the threaded Shipping Stud, rotate the Lock Lever to the 10 o'clock position (**Photo 7**).

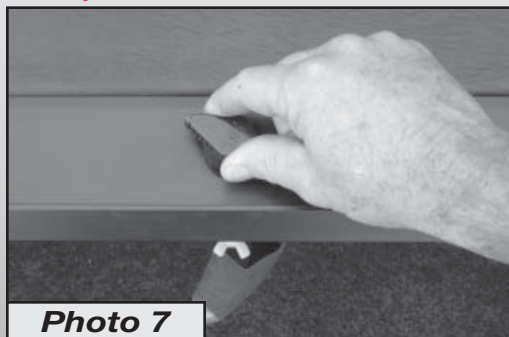

- B.** Loosely assemble six Track Clamp assemblies (**Photo 8**).

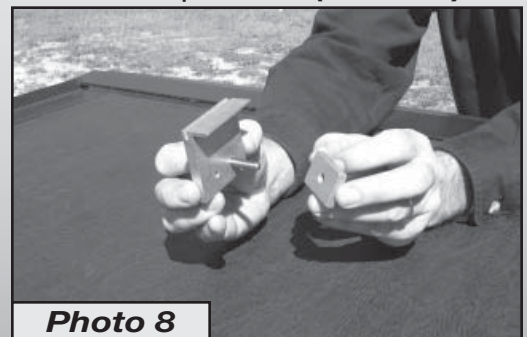

## STEP 3: INSTALL TRACKS (CONTINUED)

**C.** Remove the End Caps from the bed rail “C” channels and slide three Track Clamp assemblies into each channel (**Photo 9**). Note that the Clamps are labeled “**front**”, “**middle**”, and “**rear**” and must be located accordingly (**Photo 10**). **Leave the Clamps loose.**

**D.** Key the Tracks onto the Housing Stems (**Diagram 11**), being sure that the Handle is properly engaged into the Tracks and carefully lay the Tracks onto the bed rail (**Photo 12**) so that the fin on the underside of each Track seats into the slot in the Clamps (**Diagram 13**).

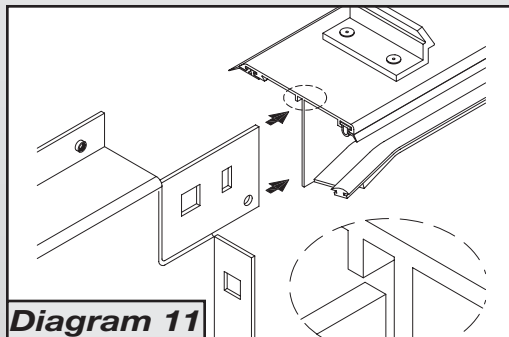
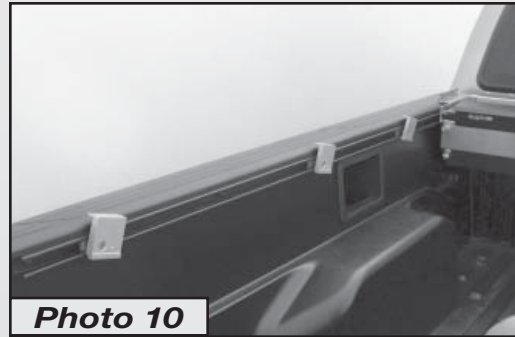
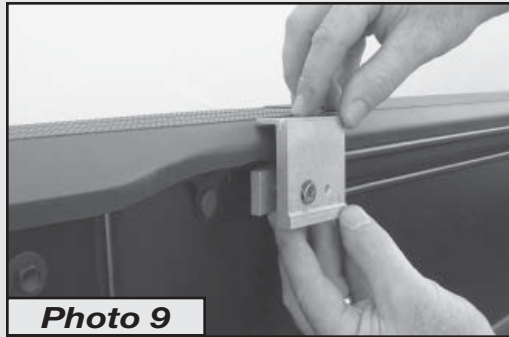

**E.** Use 10 – 24 x ½" truss head screws and Cargo Nuts to secure the Tracks to the Housing Stems (**Photo 14**).

**F.** Slide the Clamp assemblies into position so they line up with the double hole patterns located at each end and center of the Track.

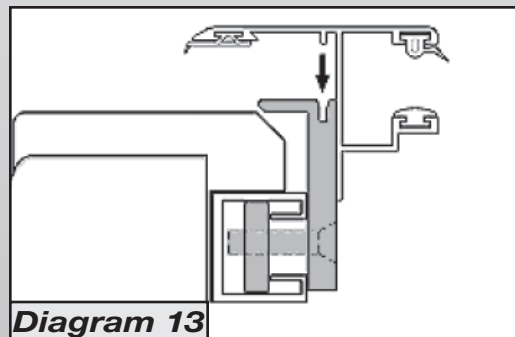

**G.** Use 10 – 24 x ½" truss head screws to secure the Clamps to the Tracks (**Photo 15**) and double

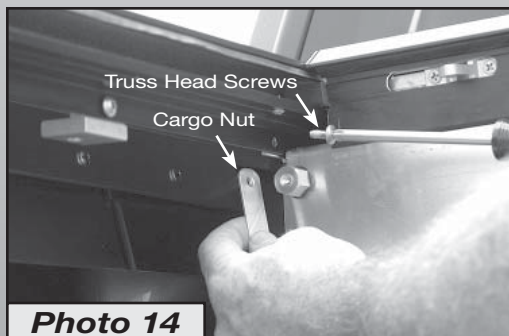

check to be sure that Tracks are properly nested into the Clamps.  
**Do not tighten Clamps in place yet and go to step four.**

## STEP 4: INSTALL TAILGATE EXTRUSION

- A.** Lower the tailgate and place the Tailgate Extrusion assembly onto the tailgate (**Photo 16**). **Note**

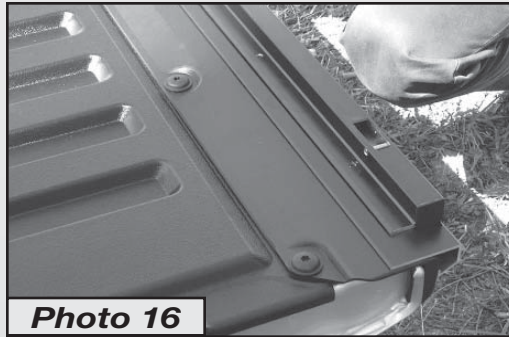

**that the end of the beveled adapter flange must be exactly flush with the end of the molded tailgate protector (Photo 17).**

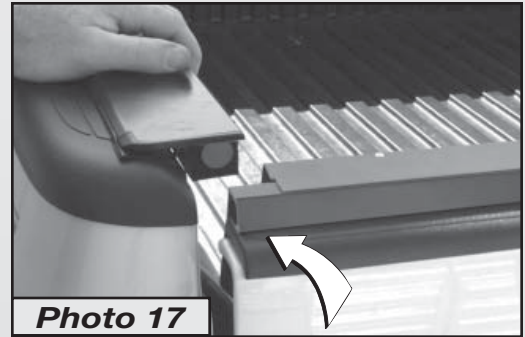

- B.** Holding the tailgate assembly square to the tailgate, use a #8 x 3/4" self tapping screw and powered screw driver and secure the center hole (**Photo 18**). **Next, move to each end, press the assembly to the top of the tailgate making it conform to the contour of the tailgate, and secure it in place.**



- C.** With the Tailgate Extrusion assembly



secured, carefully close the tailgate, being careful not to strike the ends of the Tracks.

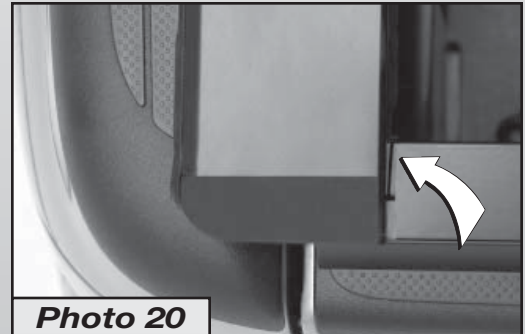

- D.** Move to the front of the bed, lift up slightly on the Housing and shift each side back toward the tailgate (**Photo 19**) so that the Track End Caps contact the inside surface of the tailgate, and match-up with the Tailgate Extrusion End Caps (**Photo 20**). **Note that if the Tracks are not positioned as shown, the Lock Mechanism will not function correctly.**

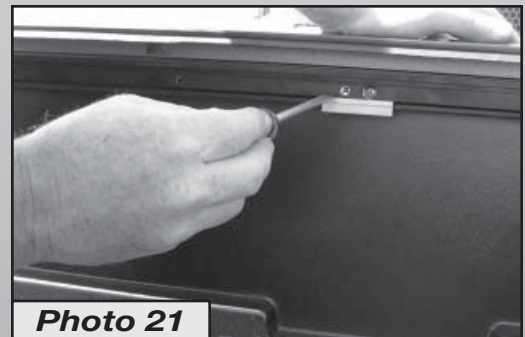

- E.** With the Tracks in the correct position, you may now tighten the Clamps (**Photo 21**). **Do not use power or pneumatic screw gun.**

## STEP 4: INSTALL TAILGATE EXTRUSION (CONTINUED)

- F.** Once tightened, the Track should be approximately 90° to the truck bed wall (**Diagram 22**). If the Track pitches upward, loosen the back Clamp and remove the two Shims (**Diagram 23**). You may find it easier to slide the back Clamp out of the bed rail “C” channel to remove the Shims.

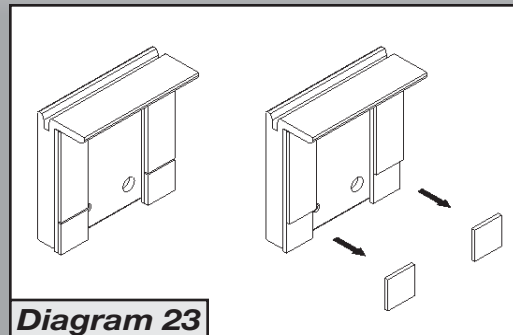
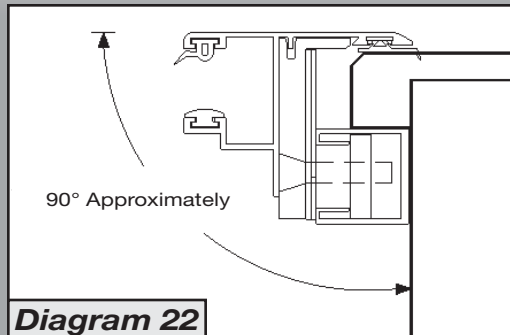

## STEP 5: INSTALL CARGO SHIELD & DRAIN TUBES

- A.** Trim the Track Gasket 1" from the end of the Track (**Photo 24**).

- B.** Rotate the Lock Lever to the 7 o'clock (closed) position (**Photo 25**), then remove the plastic wing nut and detach the Pull Strap from the threaded stud (**Photo 26**).

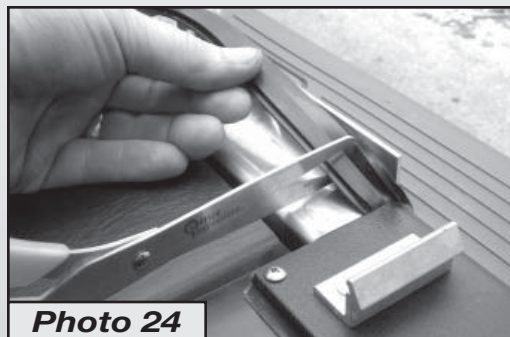

Pull the Cover closed and latch it to the tailgate. **Note: Do not allow the Cover to retract while the Housing Lid is open.**

- C.** Before lowering the Housing Lid, turn the Lid Pin Knobs ¼ turn clockwise, which will cause the pins to pop in if they are not already. Lower the Housing Lid, being sure that the Lid Pins snap into the receptors located on the Tracks.



- D.** To open the Cover pull back slightly on the Handle to relieve spring tension from the Latch Mechanisms and turn the Lock Lever clockwise to the 10 o'clock (unlatched) position.

## **STEP 5: INSTALL CARGO SHIELD & DRAIN TUBES** **(CONTINUED)**

- E.** Use 1/4-20 x 1/2" truss head screws and rubber washers to secure the Cargo Shield (*Diagram 27*). **Note: The rubber washers go on the inside of the Cargo Shield.**

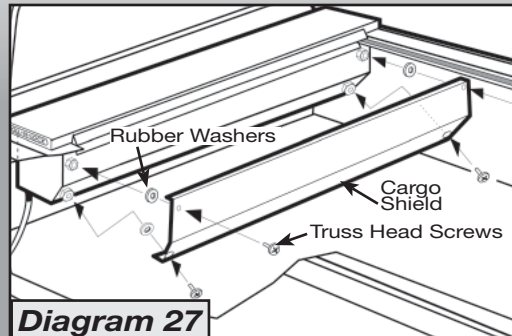

- F.** Use a 1/2" bit to drill two holes for the Drain Tubes. Note that this process is easier if a 1/4" pilot hole is drilled first. Align the holes with the Drain Fittings that protrude from the bottom of the Housing Assembly (*Photo 28*). If provided, locate the Drain Tubes in factory drain holes or bulkhead plugs.
- G.** **Always make sure the Pull-Strap is securely clipped to a fixed point in the bed.**

## **STEP 6: TEST UNIT OPERATION**

In Step 5 the Cover was opened (*retracted*). This should have caused the Lock Lever to enter the Lock Pocket and rotate to the 7 o'clock (*latched*) position.

- A.** To close the Cover, pull the Pull-Strap hand-over hand, allowing the excess strap to fall into the bed until you can reach the Handle. Place your hands evenly spread on the Handle and pull the Handle until it contacts the Tailgate Extrusion. As the Handle contacts the Tailgate Extrusion the spring loaded Latches (*which were energized when the Cover was retracted*) will automatically trip, simultaneously latching the Cover to the tailgate and side Tracks.
- B.** To open the Cover, pull back slightly on the Handle to relieve spring tension from the Latch Mechanisms and turn the Lock Lever clockwise to the 10 o'clock position. The Cover should retract on its own with only a slight push to set it into motion. When the Cover is retracting it is best to hold the Pull-Strap and allow it to slip through your fingers as the Cover travels. Applying pressure to the Pull-Strap as it slips through your fingers will act as a braking action, preventing the Handle from slamming into the Lid at high speed. The Cover must retract with only enough force to rotate and reset the Lock Lever and Latching Mechanism.

## STEP 7: INSTRUCTIONS FOR OPENING AND CLOSING THE HINGED LID

### To Open:

- A.** Grasp the Latch Pin Knobs located at the back corners of the Lid (*Diagram 29*) and pull out.
- B.** Turn the Knobs 90° to hold the Latch in the unlocked position (*Diagram 30*).
- C.** Grasp the Lid and lift (*Diagram 31*). Rest the Lid against the back of the cab to hold it open for service or cleaning.

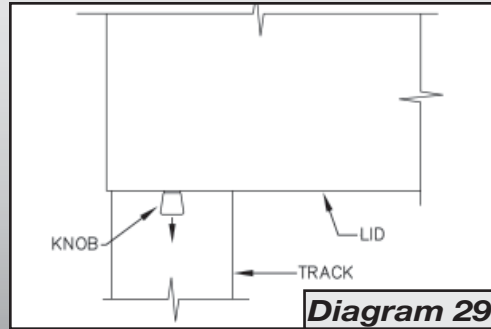

**Diagram 29**

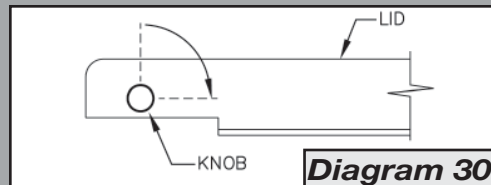

**Diagram 30**

### To Close:

- A.** Reverse the previous steps. Lower the Lid and return the Latch Pins to the locked position by turning the knobs ¼ turn.  
**Note: The Latch Pins may be returned to the locked position before or after closing the Lid.**

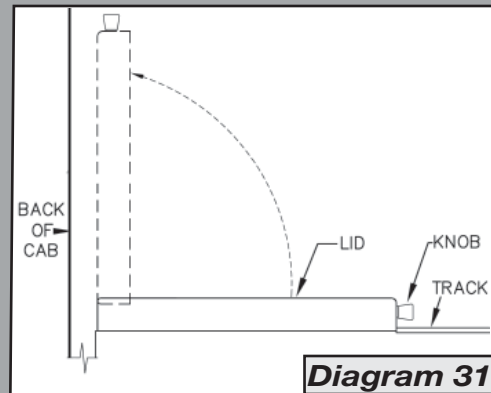

**Diagram 31**

## STEP 8: PLACE THE HANG TAG ON REVIEW MIRROR

Eliminate come-backs by giving your customers a friendly reminder of how to use and maintain their new **ROLL-N-LOCK**® retractable cover for maximum satisfaction. This hang-tag will get noticed immediately on the rear view mirror of your customer's pickup, providing them with everything they need to know. And, they will also appreciate knowing about our new **CARGO MANAGER**®; the perfect accessory for use with **ROLL-N-LOCK**® retractable covers.

