

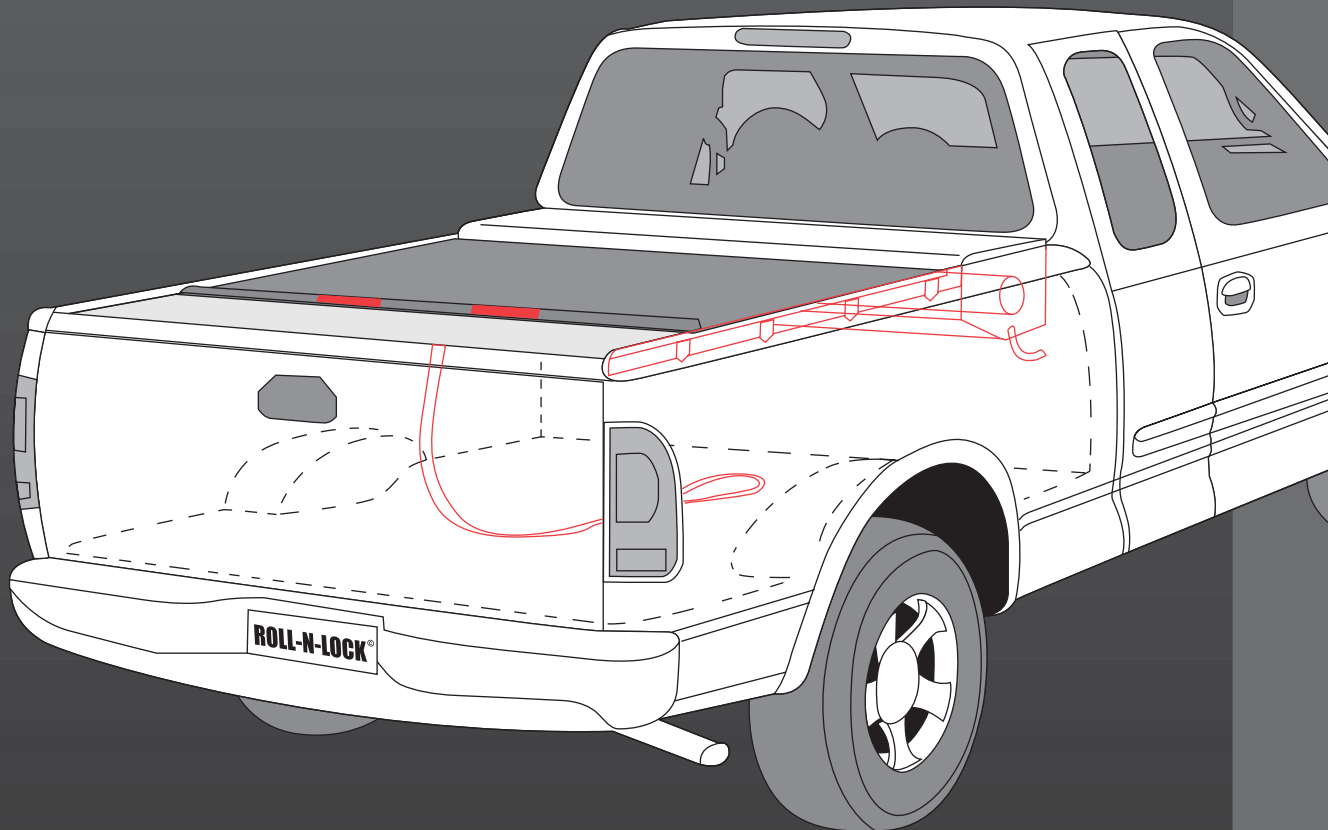

INSTALLATION GUIDE

STANDARD



PRODUCT CODES:

100, 105, 110, 111, 112, 113, 115, 120, 130,
140, 145, 146, 150, 200, 210, 240,
250, 255, 260, 300, 305, 405, 406,
407, 408, 425, 426, 435, 447, 500,
505, 510, 800, 805, 810, 820,
825, 826 & 827



Revised: June 9, 2010

INSTALLATION GUIDE

TOOLS NEEDED

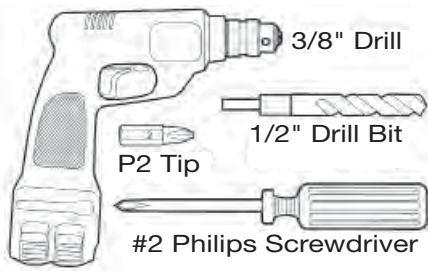

COMPONENTS INCLUDED

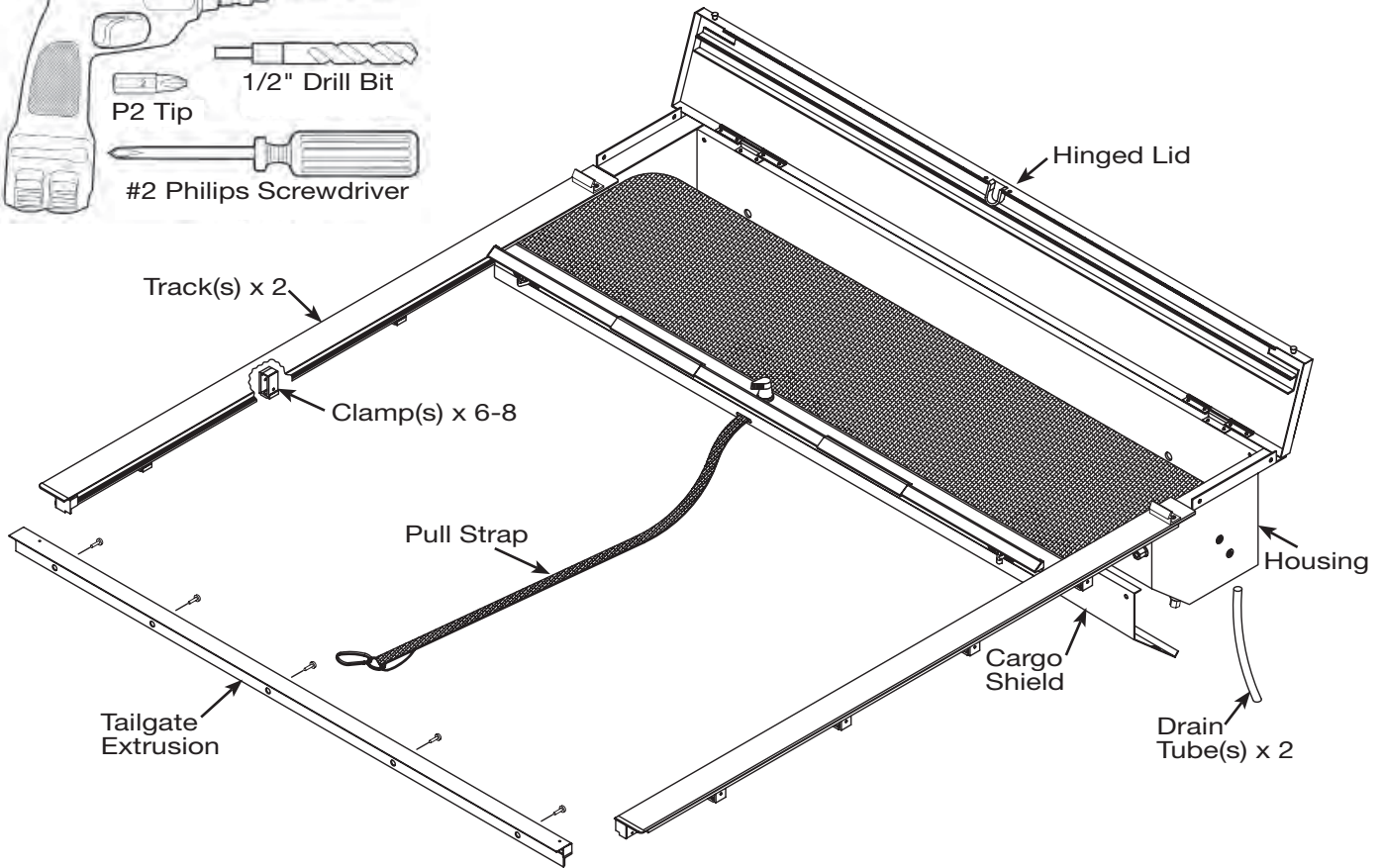

STOP!

**IF YOU HAVE A PLASTIC
DROP-IN BEDLINER, BE
SURE TO FOLLOW STEP 1
ON THE NEXT PAGE.**



**IF NO BEDLINER IS
PRESENT, PROCEED TO
STEP 2.**



(800) 952-7655 • www.rollnlock.com

STEP 1: BEDLINER MODIFICATION

Note: If the truck is equipped with a plastic drop-in bedliner, some alteration will be necessary. **If no bedliner is present, proceed to Step 2.**

A. The dotted lines in **Diagram 1** depict the more common **under-the-rail** liner modifications.

- 1.** Using a jig saw with a medium tooth blade, remove the bulkhead portion of the liner as indicated.
- 2.** **Be sure to trim the bedliner's plastic tailgate panel as shown.**

B. The dotted lines in **Diagram 2** depict the less common **over-the-rail** liner modifications.

- 1.** Using a jig saw with a medium tooth blade, remove the top cap and bulkhead portions of the liner as indicated.
- 2.** If a rear notch is necessary, place the Tracks on their respective bedrails and mark the positions of the most rearward Clamps prior to removing the liner. *(The correct position of the Track is with the black plastic Track End-Cap touching the inside surface of the tailgate.)*
- 3.** When the modification is complete, push the wall of the liner under the bedrail.
- 4.** **Be sure to trim the bedliner's plastic tailgate panel as shown.**

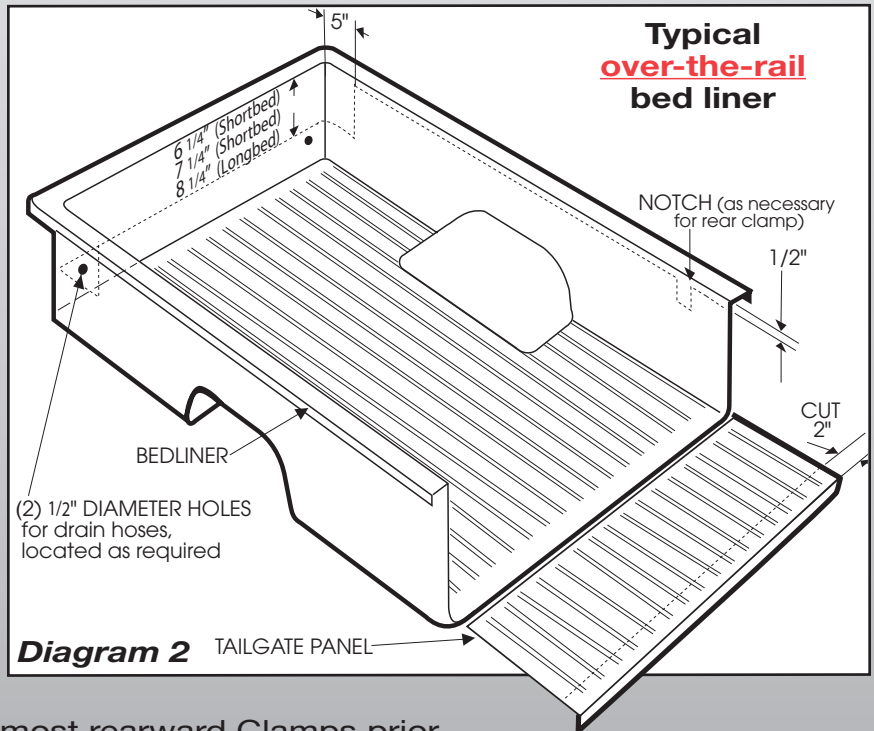
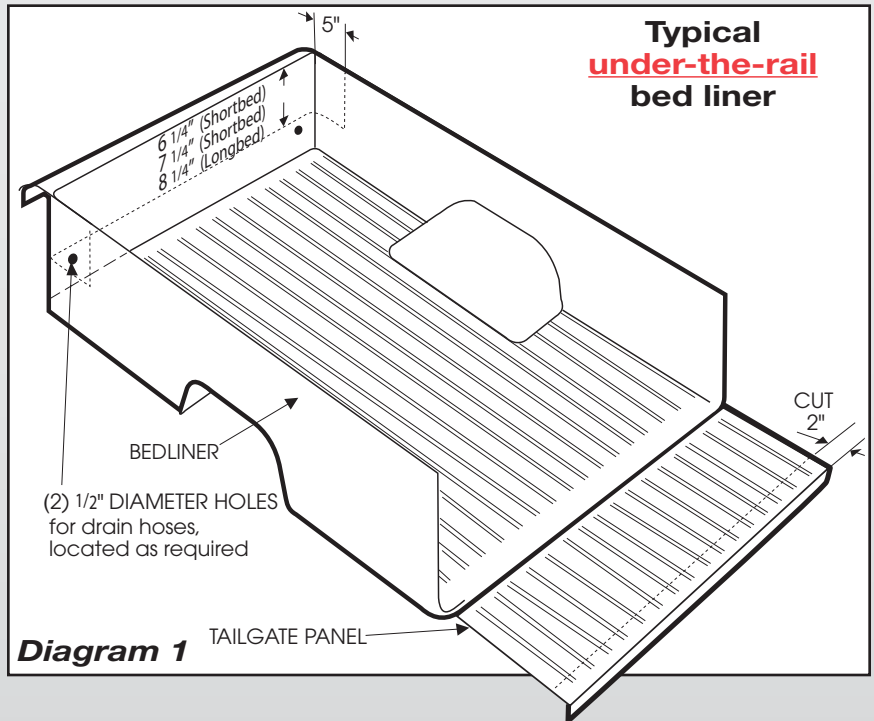

STEP 2: INSTALL THE HOUSING

- A.** If desired, install the Stake-Pocket Hole Covers where necessary (*Photo 3*).
- B.** Place the Housing Assembly onto the bedrails (*Photo 4*). This is best accomplished with two people. Center it between the bedrails and leave about ½" of space between the bulkhead and the back of the Housing.
Do not fasten the Housing in place.



- C.** Lift the Lid on the Housing and lean it against the cab. Place a rag between the Lid and cab to prevent scratches. (*Photo 5*)

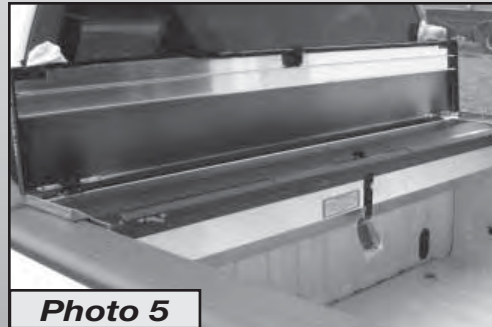

STEP 3: INSTALL THE TRACKS

- A. Making sure to leave the Pull Strap connected to the threaded shipping stud, rotate the Lock Lever to the 10 o'clock position (*Photo 6*).**
- B. Remove the "L"-shaped sections of Clamps that are taped to the bottoms of the Track Clamps (*Photo 7*). Because these are location-specific, be sure to lay them in the bed in the same order as you remove them from the Tracks.**
- C. Carefully place the Tracks on the bedrails (*Photo 8*) and key them onto the Housing Stems (*Diagram 9*), being sure that the Handle is properly engaged into the Tracks.**

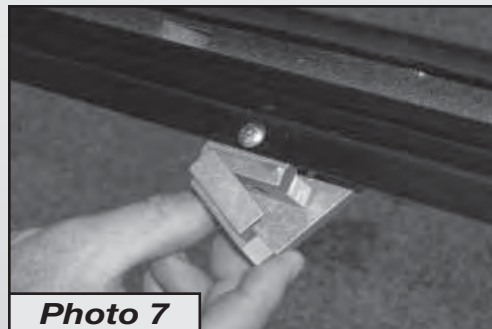
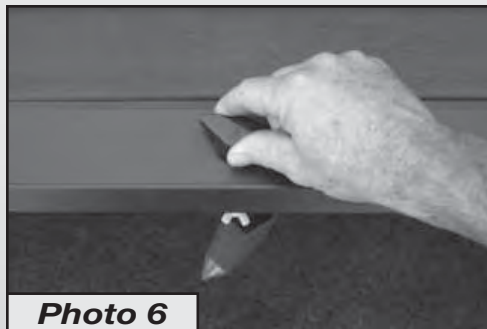

STEP 3: INSTALL THE TRACKS (CONTINUED)

- D.** Attach the back Clamps very loosely to the Tracks to be sure that the Tracks do not fall off of the bed rail while proceeding (**Photo 10**).

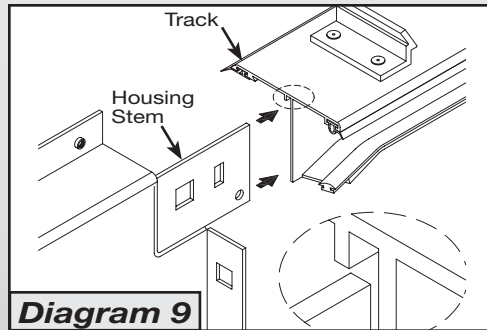

Diagram 9

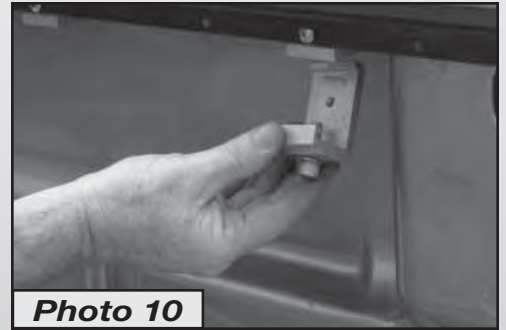

Photo 10

- E.** Use #10-24 x 1/2" truss head screws and Cargo Nuts to secure the Tracks to the Housing Stems (**Photo 11**). Tighten these connections securely.

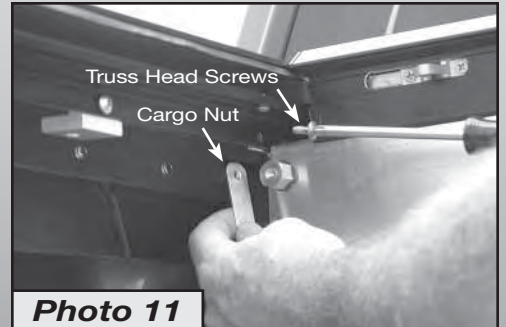

Photo 11

- F.** Attach the remaining Clamps very loosely. **Do not tighten yet.**

STEP 4: INSTALL THE TAILGATE EXTRUSION

- A.** Lower the tailgate and use a tape measure to locate and mark the center of the tailgate (**Photo 12**).
- B.** Use a tape measure to locate and mark the center of the Tailgate Extrusion (**Photo 12**).
- C.** While holding the Tailgate Extrusion square and centered on the tailgate, use a #8 x 3/4" self-tapping screw and power screw gun to secure the hole nearest center (**Photo 13**). Next, move to each end, **press the Tailgate Extrusion to the top of the tailgate in order to make it conform to the contour of the tailgate, and secure it in place.**
- D.** Install the remaining self-tapping screws, making sure to provide even spacing between them.
- E.** With the Tailgate Extrusion secured, carefully close the tailgate, being cautious not to strike the ends of the Tracks.

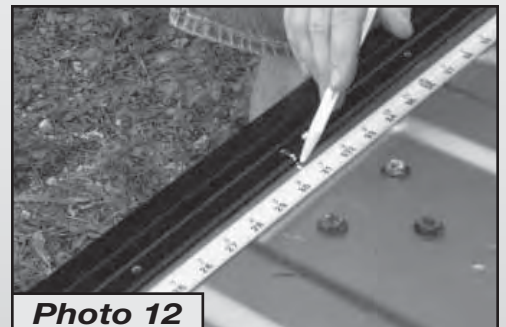

Photo 12



Photo 13

STEP 5: ORIENTING THE TRACKS TO THE TAILGATE

- A.** Move to the front of the bed, lift up slightly on the Housing and shift each side back toward the tailgate (**Photo 14**) so that the Track End-Caps contact the inside surface of the tailgate. Make sure the Track End Cap Metal Blocks contact the Tailgate Extrusion End Caps (**Photo 15**).

Note that if the Tracks are not positioned as shown, the Latch Mechanism will not function correctly.

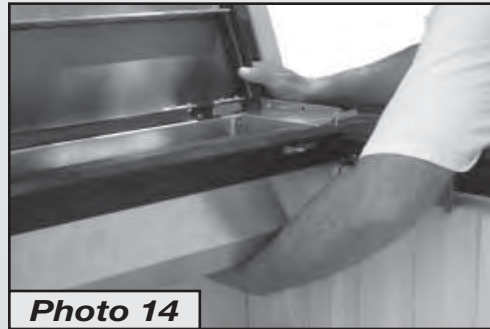

Photo 14

- B.** With the Tracks in the correct position, you may now tighten the Clamps in the order shown

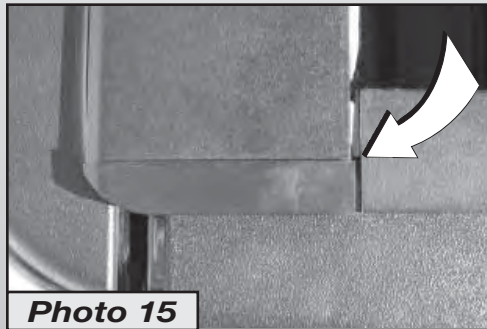

Photo 15

(**Diagram 16**), taking care to make sure the Tracks remain level.

Do not use a power or pneumatic screw gun. Over tightening Track Clamps can cause an indentation in the bedrails.

- C.** If the Track pitches upward, loosen the Clamp, rotate the Track level and install the optional Angularity Adjustment Screw as shown (**Diagram 17**). Tighten the screw until it biases against the bedrail down-flange as shown.

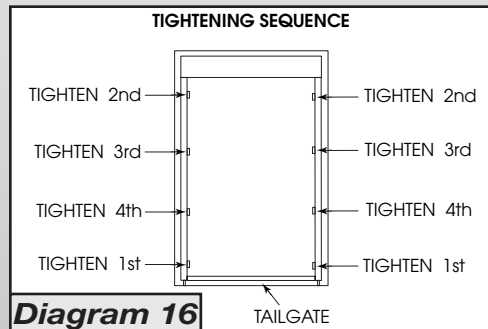

Diagram 16

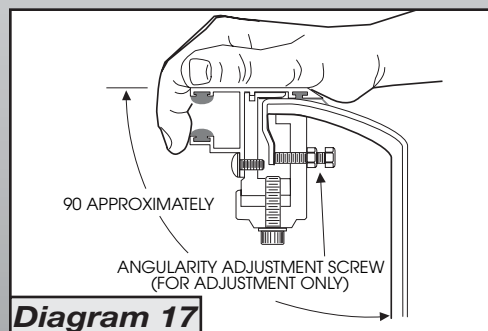

Diagram 17

STEP 6: INSTALL CARGO SHIELD & DRAIN TUBES

- A.** Trim the track gasket 1" from the end of the Track (**Photo 18**),
- B.** Rotate the Lock Lever to the 7 o'clock (*closed*) position (**Photo 19**), then remove the plastic wing nut and detach the Pull Strap from the threaded Stud (**Photo 20**). Pull the Cover closed and latch it to the tailgate.

Note: Do not allow the Cover to retract while the Housing Lid is open.

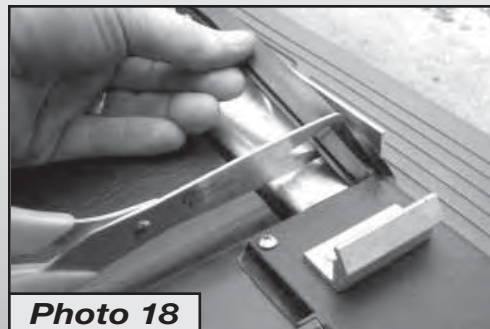

Photo 18

- C.** Before lowering the Housing Lid, turn the Lid Pin Knobs $\frac{1}{4}$ turn clockwise, which will cause the pins to pop in if they are not already. Lower the Housing Lid, being sure that the Lid Pins snap into the receptors located on the Tracks.

STEP 6: INSTALL CARGO SHIELD & DRAIN TUBES

- D.** To open the Cover pull back slightly on the Handle to relieve spring tension from the Latch Mechanisms and turn the Lock Lever clockwise to the 10 o'clock (*unlatched*) position.



- E.** Use 1/4-20 x 1/2" truss head screws and rubber washers to secure the Cargo Shield (*Diagram 21*).

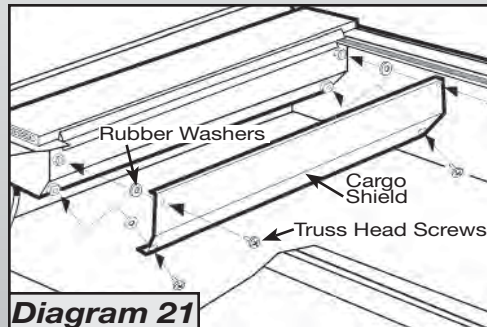

Note: The rubber washers go on the inside of the Cargo Shield.

- F.** Use 1/2" bit to drill 2 holes for the Drain Tubes. Note that this process is easier if 1/4" pilot hole is drilled first. Align the holes with the Drain Fittings that protrude from the bottom of the Housing Assembly (*Photo 22*). If provided, locate the Drain Tubes in factory drain holes or bulkhead plugs.
- G.** Always make sure the Pull-Strap is securely clipped to a fixed point in the bed.

STEP 7: TEST UNIT OPERATION

In Step 6 the Cover was opened (*retracted*). This should have caused the Lock Lever to enter the Lock Pocket and rotate to the 7 o'clock (*latched*) position.

- A. To close the Cover,** pull the Pull-Strap hand-over hand, allowing the excess strap to fall into the bed until you can reach the Handle. Place your hands evenly spread on the Handle and pull the Handle until it contacts the Tailgate Extrusion. As the Handle contacts the Tailgate Extrusion the spring loaded Latches (*which were energized when the Cover was retracted*) will automatically trip, simultaneously latching the Cover to the tailgate and side Tracks.
- B. To open the Cover,** pull back slightly on the Handle to relieve spring tension from the Latch Mechanisms and turn the Lock Lever clockwise to the 10 o'clock position. The Cover should retract on its own with only a slight push to set it into motion. When the Cover is retracting it is best to hold the Pull-Strap and allow it to slip through your fingers as the Cover travels. Applying pressure to the Pull-Strap as it slips through your fingers will act as a braking action, preventing the Handle from slamming into the Lid at high speed. The Cover must retract with only enough force to rotate and reset the Lock Lever and Latching Mechanism.

STEP 8: INSTRUCTIONS FOR OPENING AND CLOSING THE HINGED LID

To Open:

- A.** Grasp the Latch Pin Knobs located at the back corners of the Lid (**Diagram 23**) and pull out.
- B.** Turn knobs 90° to hold Latch in the unlocked position (**Diagram 24**).
- C.** Grasp the Lid and lift (**Diagram 25**). Rest the Lid against the back of the cab to hold open for service or cleaning.

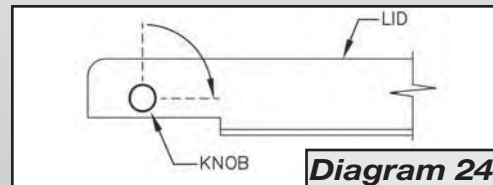
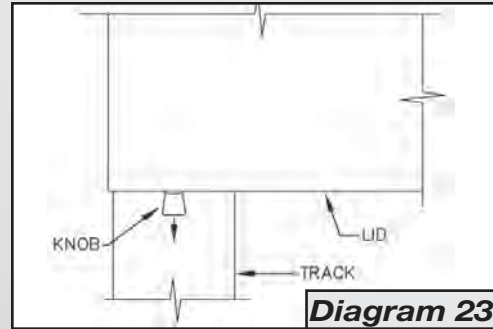

To Close:

- A.** Reverse the previous steps. Lower the Lid and return the Latch Pins to the locked position by turning the knobs ¼ turn.
Note: The Latch Pins may be returned to the locked position before or after closing the Lid.

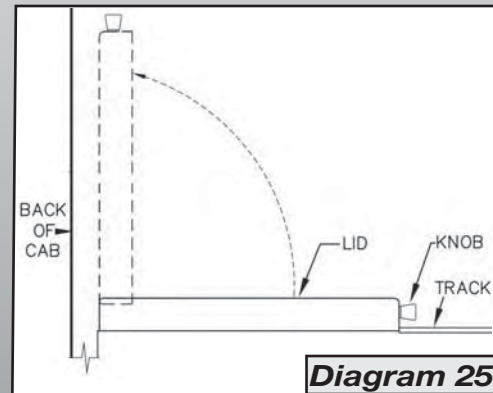

STEP 9: PLACE THE HANG TAG ON REVIEW MIRROR

Eliminate come-backs by giving your customers a friendly reminder of how to use and maintain their new **ROLL-N-LOCK**® retractable cover for maximum satisfaction. This hang-tag will get noticed immediately on the rear view mirror of your customer's pickup, providing them with everything they need to know. And, they will also appreciate knowing about our new **CARGO MANAGER**®; the perfect accessory for use with **ROLL-N-LOCK**® retractable covers.

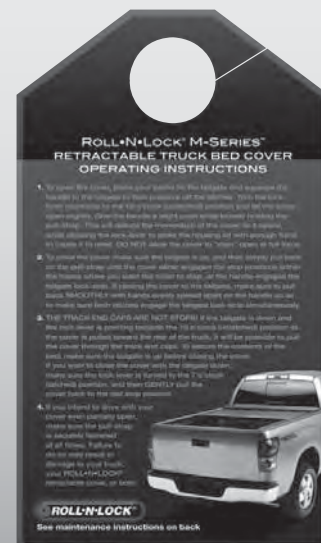

SUPPLEMENTAL GUIDE: 802, 803, 807 & 809

IMPORTANT NOTICE READ THIS FIRST

Depending on the bed design of the truck in question, this cover may be installed in one of two ways.

1. If the truck bed is equipped with the "Utilitrack" bed system, follow the instructions detailed on the attached page for adaptation of the Roll•N•Lock Tracks to the "Utilitrack" C-channel.
2. If the truck bed is **NOT** equipped with the "Utilitrack" bed system, proceed with the standard "clamp-on" installation, which is detailed in the enclosed installation guide.

TRACK/CLAMP MOUNTING DETAIL

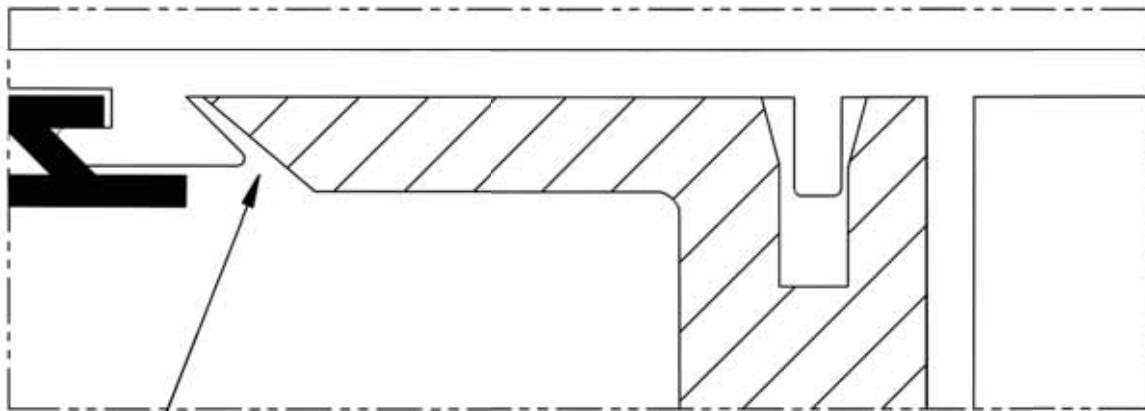

Very important that Track Clamp keys into Track as shown.

Detail A

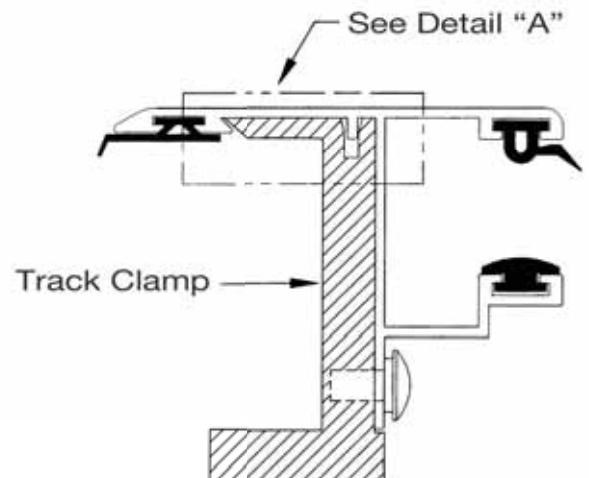

SUPPLEMENTAL GUIDE: 802, 803, 807 & 809

INSTALLATION DETAIL FOR ADAPTATION TO "UTILITRACK" C-CHANNEL

STEP 1: Secure Track to Mounting Flange using #10 - 24 x 1/2" screws, lock washers and hex nuts.

STEP 2: Place three Threaded Blocks in "C" Channel.

STEP 3: Place Track and Flange assembly onto bed rail. Locate so that Plastic Track Caps are touching vertical face of tailgate. Slide Threaded Blocks along "C" channel and align with holes on flange tabs. Use 5/16" - 18 x 1" socket head screw to secure assembly on "C" channel.

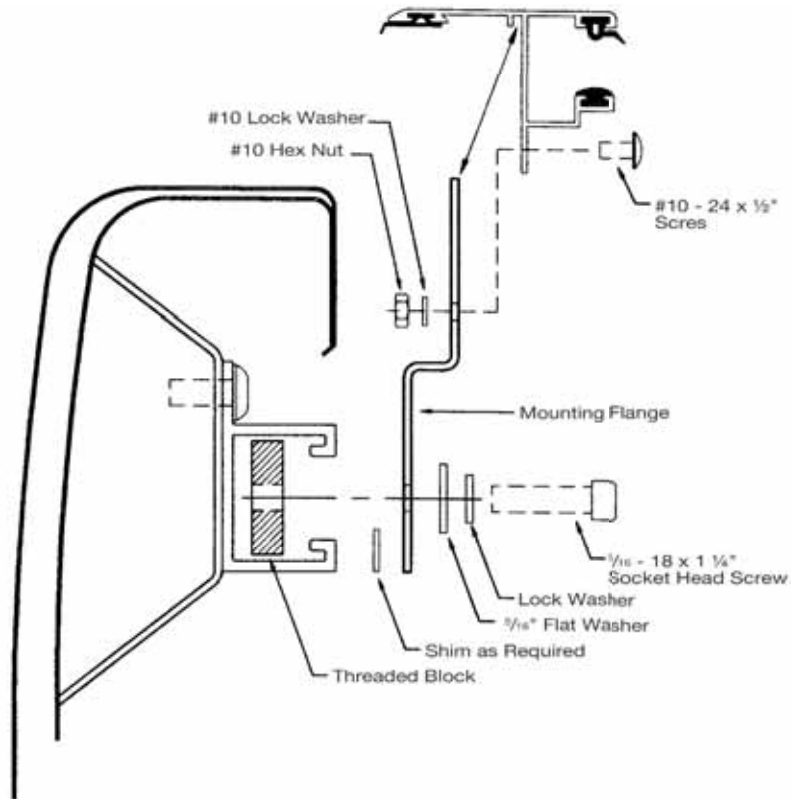

COMPLETED ASSEMBLY SHOWN

