



**INSTALLATION INSTRUCTIONS FOR 1994-2002
DODGE 2500/3500 4WD
TRACK BAR CONVERSION KIT
PART NUMBER 708**







WARNING!!! READ AND UNDERSTAND ALL INSTRUCTIONS BEFORE PROCEEDING. MAKE SURE THAT YOU HAVE ALL TOOLS AND PARTS BEFORE BEGINNING THE INSTALLATION.

REVTEK SUSPENSION RECOMMENDS THAT RED LOCTITE BE USED ON ALL FASTENERS UNLESS OTHERWISE NOTED. IT IS ALSO RECOMMENDED TO HAVE THE FRONT END ALIGNMENT CHECKED AFTER INSTALLATION.

GENERAL NOTES:

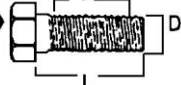
1. THIS SYSTEM SHOULD ONLY BE INSTALLED BY A PROFESSIONAL.
2. COMPARE ALL CONTENTS OF THE BOXES TO THE PARTS LIST BEFORE STARTING TO INSURE ALL COMPONENTS ARE INCLUDED.
3. Prior to installing the suspension system, inspect the vehicle's suspension components, alignment, and frame for damage, corrosion, or cracks. Correct any worn or damaged parts before beginning install.
4. Always wear safety glasses during installation.
5. Unless otherwise noted, tighten all bolts to the torque specifications listed in the Torque Specification table included in these instructions. Use a torque wrench.
6. Estimated time to install this system is 6 hours.
7. Check off the step number at the beginning of each step when you finish it. Then when you stop during the installation, it will be easier to find where you need to continue from.

STANDARD BOLT TORQUE & IDENTIFICATION						
INCH SYSTEM			METRIC SYSTEM			
Bolt Size	Grade 5	Grade 8	Bolt Size	Class 9.8	Class 10.9	Class 12.9
5/16	15 ft. lbs.	20 ft. lbs.	M6	5 ft. lbs.	9 ft. lbs.	12 ft. lbs.
3/8	30 ft. lbs.	35 ft. lbs.	M8	18 ft. lbs.	23 ft. lbs.	27 ft. lbs.
7/16	45 ft. lbs.	60 ft. lbs.	M10	32 ft. lbs.	45 ft. lbs.	50 ft. lbs.
1/2	65 ft. lbs.	90 ft. lbs.	M12	55 ft. lbs.	75 ft. lbs.	90 ft. lbs.
9/16	95 ft. lbs.	130 ft. lbs.	M14	85 ft. lbs.	120 ft. lbs.	145 ft. lbs.
5/8	135 ft. lbs.	175 ft. lbs.	M16	130 ft. lbs.	165 ft. lbs.	210 ft. lbs.
3/4	185 ft. lbs.	280 ft. lbs.	M18	170 ft. lbs.	240 ft. lbs.	290 ft. lbs.

<p>1/2-13x1.75 HHCS</p> <p style="text-align: center;">D T L X</p> <div style="display: flex; justify-content: space-around; align-items: center;"> <div style="text-align: center;">  Grade 5 </div> <div style="text-align: center;">  Grade 8 </div> </div> <p style="text-align: center;">  </p> <p> G= Grade Marking (bolt strength) L= Length (inches) D= Nominal Diameter (inches) X= Description (hex head cap screw) T= Thread Pitch (threads per inch) </p>	<p>M12-1.25x50 HHCS</p> <p style="text-align: center;">D T L X</p> <div style="display: flex; justify-content: space-around; align-items: center;"> <div style="text-align: center;">  P </div> <div style="text-align: center;">  10.9 </div> </div> <p style="text-align: center;">  </p> <p> P= Property Class (bolt strength) L= Length (millimeters) D= Nominal Diameter (millimeters) X= Description (hex head cap screw) T= Thread Pitch (thread width, mm) </p>
--	---

KIT CONTENTS INCLUDE:

- Instructions including parts list
- Product Safety Label (orange)
- Decal
- Warranty Information

<i>ADJUSTABLE TRACK BAR</i>	1
<i>ADJUSTABLE TRACK BAR BUSHINGS</i>	4
<i>ADJUSTABLE TRACK BAR SLEEVE 16MM</i>	2
<i>ADJUSTABLE TRACK BAR SLEEVE 14MM</i>	2
<i>TAPERED SLEEVE FOR TRACK BAR BRACKET</i>	1
<i>TRACK BAR CONVERSION BRACKET</i>	1
<i>½-13 GRADE C ALL METAL LOCK NUT</i>	1
<i>SAE ½ FLAT WASHER</i>	4
<i>½-13 X 5" GRADE 8 BOLT</i>	1
<i>5/8 X 2-1/2" GRADE 8 BOLT</i>	1
<i>5/8 ALL METAL LOCK NUT</i>	1
<i>5/8 FLAT WASHER</i>	2
<i>9/16 X 3" GRADE 8 BOLT</i>	1
<i>9/16 ALL METAL LOCK NUT</i>	1
<i>SAE 9/16 FLAT WASHER</i>	2
<i>INSTRUCTION SHEET & SAFETY LABEL</i>	1

- 1) Place vehicle on level concrete surface and chock rear wheels.
- 2) Remove the Track bar from the vehicle. Save lower bolt for re-installation.
- 3) Remove the rear steering box bolt and retain for re-installation.
- 4) Make sure lower surface of frame is flat for mounting the track bar bracket. Some 94-95 models have a small brace bolted to the cross member and frame tab, this will need to be removed if the bracket does not seat properly.
- 5) Insert ½" x 5" bolt with washer. This bolt will go from the top down and will be located on the cross member next to the steering box shaft. The bolt will sit at an angle with the threads exposed below the cross member. See Figure A.
- 6) Insert tapered bushing into the tapered frame tab hole that the stock track bar tie rod was removed from.

7) Hold the new Revtek Track bar into place and insert a washer and finger tighten the nut onto the exposed threads from the 5" bolt that was installed through the cross member. This bolt will go through the center hole on the bracket. Do not tighten at this time. See Figure A.

8) Insert stock steering box bolt through the forward hole in the Revtek bracket and back into the steering box. Do not tighten at this time. See Figure B.

9) Insert 5/8 x 2.5" bolt from the bottom up through the tapered hole where the stock track bar used to mount. Make sure tapered sleeve did not fall out while mounting track bar bracket.

10) After all bolts are inserted into bracket, please tighten the 5/8 x 2.5" to 180 ft. lbs, then tighten the steering box bolt to 135 ft. lbs, and finally tighten the center 5" bolt to 40ft. lbs.

11) Install the new Adjustable Revtek track bar. Use the correct bushing sleeves for your year; do this by comparing the stock lower track bar bolt to the sleeve. Bolt up at this time by turning the steering wheel slightly side to side in order to line up the hole. Install the remaining 9/16" x 3-1/4" bolt in the upper hole. It is now time to tighten and torque all hardware concerning the track bar bracket. All 9/16" bolts torque to 85 ft. lbs and the lower bolt torque to 55 ft. lbs.



FIGURE A



FIGURE B

Important Installation Notes:

- Manufacturing tolerances do create certain variations that we cannot fully account for. At times you may need to use a punch, or pry bar to get holes to line up. Also you may need to slightly enlarge a hole to create a proper alignment. These are all normal situations.
- Altering your suspension may change the way your vehicle handles. Care must be taken to operate your vehicle safely.
- Adding large wheels and tires, will change how your suspension operates. It may put extra strain on certain components causing them to wear sooner than normal.
- While every effort is made to design our kits to work within factory geometry, there are situations where additional alignment tools like adjustable or replacement components may be needed. This is normal.
- It is possible when changing the driveline angles that a vibration may occur, and require an adjustment to repair this situation.
- Other modifications may be needed due to optional equipment on the vehicle or other prior modifications that have been made.
- All fasteners should be checked and retightened after 500 miles. After the initial recheck, they should be checked and tightened as needed with every following service.
- Once the installation is complete a thorough road test should be performed to verify proper clearance of all items.
- Revtek Suspension kits are designed for race applications.
- Altering the suspension on your vehicle may change the characteristics of some systems such as: fuel economy, transmission shift points, etc.
- While Revtek systems are designed to work within all factory specifications and tolerances, there are some situations where exceeding the capability of the vehicle such as load capacity or speed will result in some undesirable results. If you overload your vehicle it will not handle correctly. If you drive or turn with excessive speed your vehicle will handle differently and some onboard vehicle systems may detect this and take appropriate action.
- Our tire and wheel fitments are only a guideline. Different production times or tolerances will vary and this sizes should only be used as a starting point. Each vehicle is different and will need to be treated as such.
- Our lift heights can vary slightly based on manufacturing tolerances. Some vehicles will exhibit slightly different amounts of lift heights and different final heights. Every vehicle is not identical and every vehicle will not be perfectly the same at all four corners.
- Once your vehicle is lifted components may wear faster, this is normal. A lifted vehicle is exerting more stress on most components and therefor causing them to wear faster.
- After altering the height of your vehicle, you should aim the headlights for proper coverage.
- The use of Loctite on fasteners is highly recommended.



Limited Lifetime Warranty

Revtek Suspension products are warranted to be free from material and workmanship defects for as long as the original retail purchaser owns the vehicle upon which such products were originally installed (proof of purchase required). The consumer will be responsible for removing from the vehicle and returning any defective item, freight prepaid, and for reinstallation. This warranty is non-transferable. Revtek Suspension's limit of liability under this warranty is to repair or replace the product at Revtek Suspension's option. Consequential costs such as, but not limited to labor fees, loss of use, loss of time or freight charges are not covered. Any product that has been abused, altered incorrectly installed, or used in competition is not covered. Product finish is excluded from this warranty. Items that are subject to wear are not considered defective when worn and are not covered. The warranty is void if the "Warning to Driver" decal is not properly displayed on the vehicle. No other warranties are expressed or implied. We reserve the right to make changes in design, materials, and specifications without prior notice.

This warranty gives you specific legal rights and you may also have other rights which may vary from state to state. Some states do not allow limitations on how long an implied warranty lasts or allow the exclusion or limitation of incidental or consequential damages, the above limitation or exclusion may not apply to you.

Other than stated above, there are no warranties.

SELLER DISCLAIMS ANY IMPLIED WARRANTY OF MERCHANTABILITY

SELLER DISCLAIMS ANY IMPLIED WARRANTY OF FITNESS FOR A PARTICULAR PURPOSE

This warranty to be free from material and workmanship defects shall not apply to any product which has been improperly installed modified or customized and does not apply to any components used for racing purposes or racing type activities.

To make a claim under this warranty to be free from material and workmanship defects, contact Revtek Suspension about the problem prior to removing any parts from the vehicle. If it appears that the part is warrantable, you will be given a Return Authorization (RA) number and asked to return the part freight prepaid. If the part is found to be warrantable, it will be repaired or replaced and returned to you. All freight charges are the customer's responsibility. If a replacement part is needed before the part in question can be returned, you must first purchase the replacement part. Then if the part in question is deemed warrantable, you will be credited / refunded.

Shocks and bushings are considered to be wear items. As such, they will be covered for a period of 12 months from the original installation. Any failure outside of 12 months will be considered typical wear.

REVTEK SUSPENSION, LLC 503-659-1650
2800 Taylor Way BLDG 2A, Forest Grove, OR 97116