



3651 N Highway 89 • Chino Valley, AZ 86323
(928) 636-7080 • www.p-a-g.net

FORD F150 CREW CAB INSTALLATION INSTRUCTIONS 2001-2002 **KIT# 70013**

⚠ WARNING
Installation of a Performance Automotive Group body lift kit will change the vehicle's center of gravity and handling characteristics both on- and off-road. You must drive the vehicle safely! Extreme care must be taken to prevent vehicle rollover or loss of control, which could result in serious injury or death. Avoid sudden sharp turns or abrupt maneuvers and always make sure all vehicle occupants have their seat belts fastened.

⚠ WARNING
Before you install this kit, read and understand all instructions, warnings, cautions, and notes in this instruction sheet and in the vehicle owner's manual.

⚠ CAUTION
Proper installation of this kit requires knowledge of the factory recommended procedures for removal and installation of original equipment components. We recommend that the factory shop manual and any special tools needed to service your vehicle be on hand during the installation. Installation of this kit without proper knowledge of the factory recommended procedures may affect the performance of these components and the safety of the vehicle. We strongly recommend that a certified mechanic familiar with the installation of similar components install this kit.

⚠ WARNING
DO NOT combine suspension, body, or other lift devices. Use of vehicle with combined lifts may result in unsafe and/or unexpected handling characteristics.

⚠ WARNING
This kit should only be installed on a vehicle that is in good working condition. Before you install the kit, thoroughly inspect the vehicle for corrosion or deformation of the sheet metal around the factory body mounts. If the vehicle is suspected to have been in a collision or misused, do not install this kit. Off-road use of your vehicle with this kit installed may increase the stress applied to the factory body mounts. We do not recommend that any vehicle with a body lift kit installed be involved in any extreme off-road maneuvers such as jumping. Failure to observe this warning may result in serious personal injury and/or severe damage to your vehicle.

⚠ WARNING
Many states and municipalities have laws restricting bumper heights and vehicle lifts. Consult state and local laws to determine if the changes you intend to make to the vehicle comply with the law.

⚠ WARNING
The installation of larger tires may reduce the effectiveness of the braking system.

⚠ WARNING
Always wear eye protection when operating power tools.

⚠ WARNING
Before you install this kit, block the vehicle tires to prevent the vehicle from rolling.

⚠ WARNING
Accidental deployment of the air bag can result in serious personal injury or death. To avoid accidental deployment during installation of the kit, the Supplemental Restraint System (SRS, or airbag) must remain deactivated. Do not allow anyone near the airbag during installation. Refer to the factory service manual or owner's manual for the recommended procedure to disable the SRS. After you install the kit, reactivate the SRS before driving the vehicle.

NOTE
Performance Automotive Group recommends using the Loctite® supplied in the kit on the threads of all kit nuts and bolts unless specified otherwise in these instructions.

A. Before you start.

⚠NOTE

As you read through this procedure, note that each part referenced has the same callout number throughout. Also, the part number in the text matches the corresponding part number in the art. Kit parts are prefaced by the word *kit* in italics.

⚠NOTE

You will find it easier to keep track of hardware if immediately after removal you put the fasteners for each subassembly in a paper lunch bag and write on the bag where they go.

1. Read all warnings and instructions completely and carefully before you begin.
2. Check to make sure the kit is complete (refer to the Parts List, section E).
3. Only install this kit on the vehicle for which it is intended. If anytime during the installation you encounter something different from what is outlined in the instructions, call technical support at (928) 636-0979.
4. Park the vehicle on a clean, dry, flat, level surface and block the tires so the vehicle cannot roll in either direction.
5. Disconnect both battery cables. Disconnect the negative cable (1) first, then the positive cable (2) from the battery (3).
6. Remove two covers (4 and 5) and the airbag fuse (6) from the fuse panel (7).

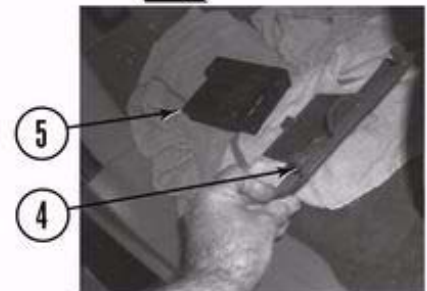
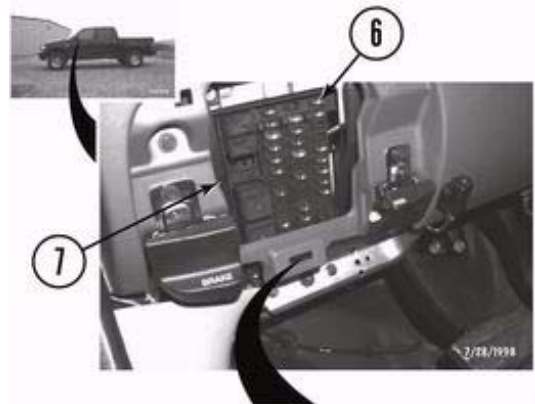
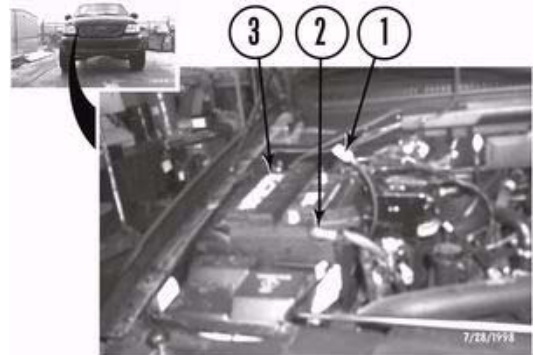

B. Get ready to install the kit.

1. Remove the front bumper.

a. Measure distance between the front bumper (8) and front fenders (9). Record measurement.

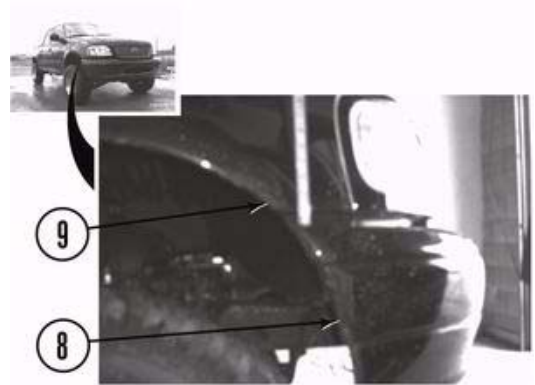

b. If so equipped, remove two connectors (10) from fog lamps (11).

c. Remove eight panel clips (12) and air flap (13) from front bumper (8) and core support (14).

d. Remove four nuts (15) and front bumper (8) from frame (16).

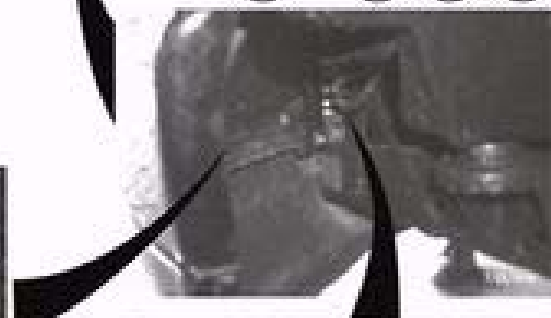
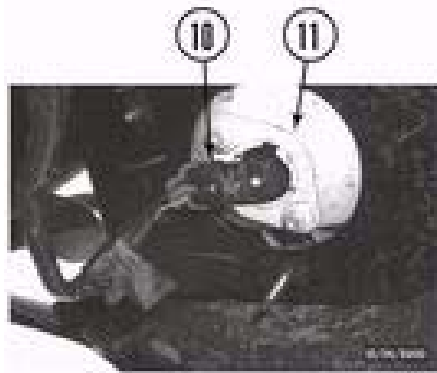
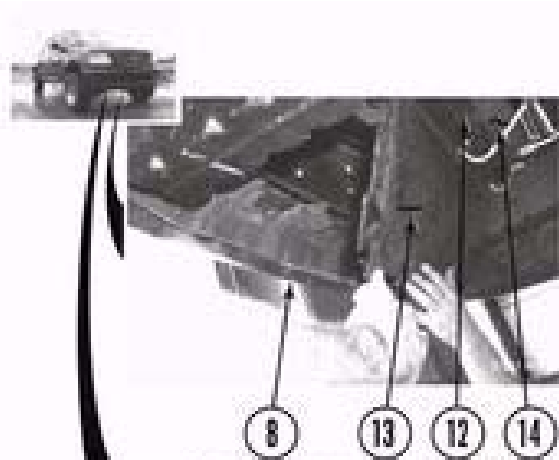

2. Remove the rear bumper.

a. Disconnect two license plate lights (17) from the rear bumper (18).

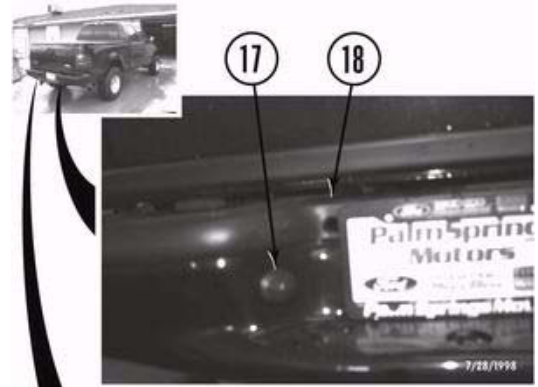

b. Remove four nuts (19) and rear bumper (18) from frame (16).

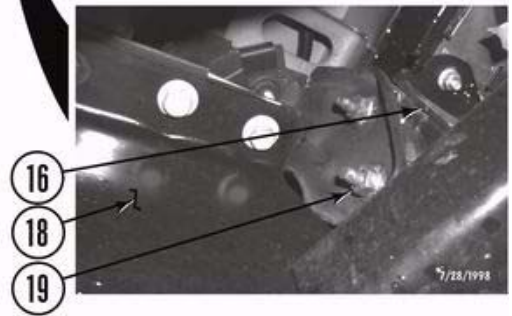

3. Under the hood.

a. Remove two screws (20) from radiator shroud (21) and fan shroud (22).



b. Remove two screws (23) from fan shroud (22) and radiator (24).

c. Pull radiator shroud (21) up and back from fan shroud (22), off of two top click-in mounting tabs (25). Rest fan shroud on fan.

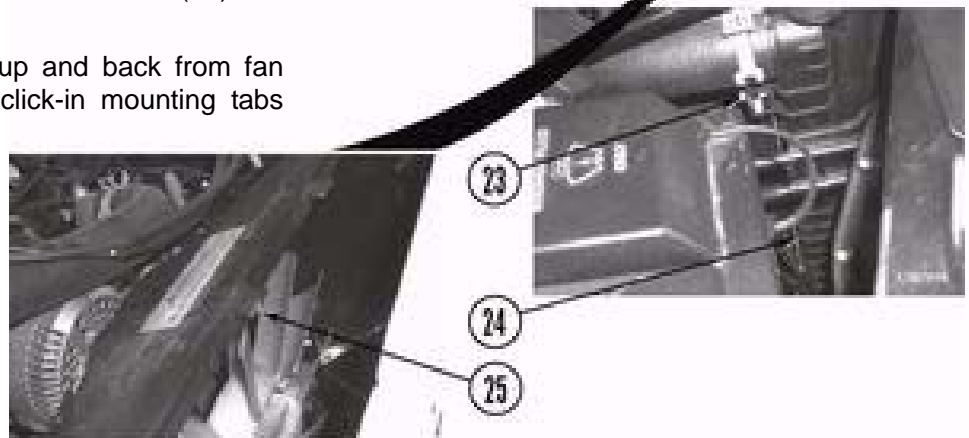

d. Remove spare tire crank (26) from clips (27).

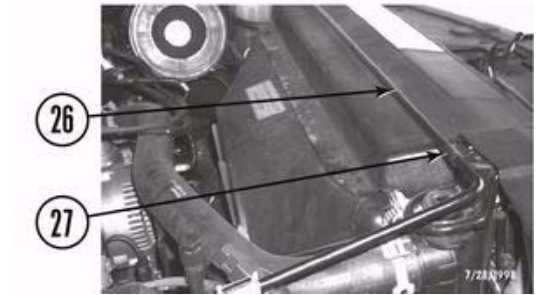

e. Remove seven screws (20) and radiator shroud (21) from core support (14).



f. Remove three screws with captive washers (28) and fuel injection cover (29) from the throttle body (30).

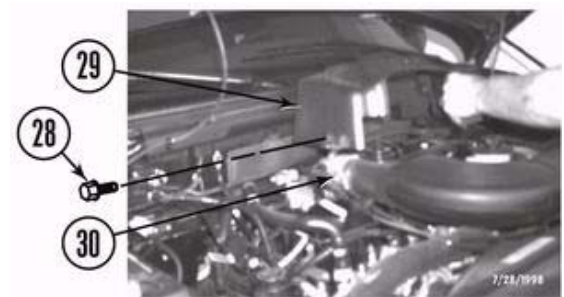

g. Remove clamp (31) from air duct (32) and throttle body (30).

h. Remove two hoses (33) from air duct (32) and throttle body (30).



i. Loosen clamp (34) and remove air duct (32) from air filter housing (35). Move air duct out of way.



⚠️WARNING

Ensure radiator has cooled completely before removing radiator cap. Radiator coolant is **HOT** and **UNDER PRESSURE**. Serious personal injury may result if cap is removed before radiator has cooled.

- j. Remove radiator cap (36) from overflow bottle (37).
- k. Drain radiator (24) into a clean container.

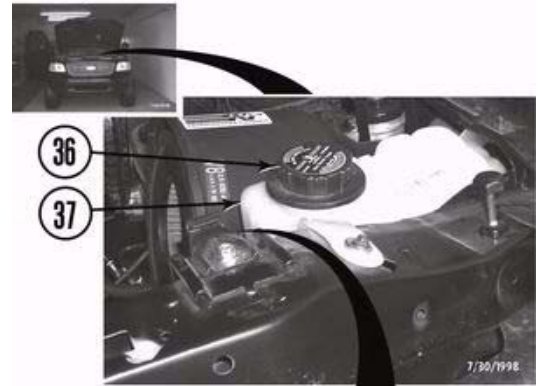

- l. Squeeze clamp (38) and remove hose (39) from radiator (24).
- m. If equipped with automatic transmission, remove two transmission cooling lines (40 and 41).

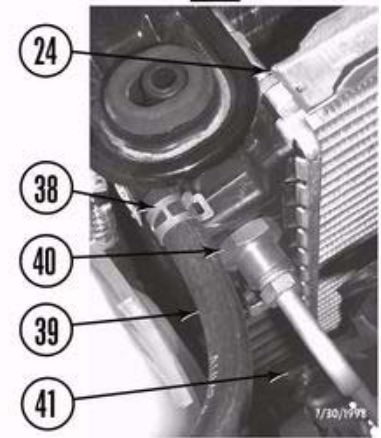

- n. Squeeze two clamps (42 and 43) and remove upper radiator hose (44) and lower radiator hose (45) from radiator (24).

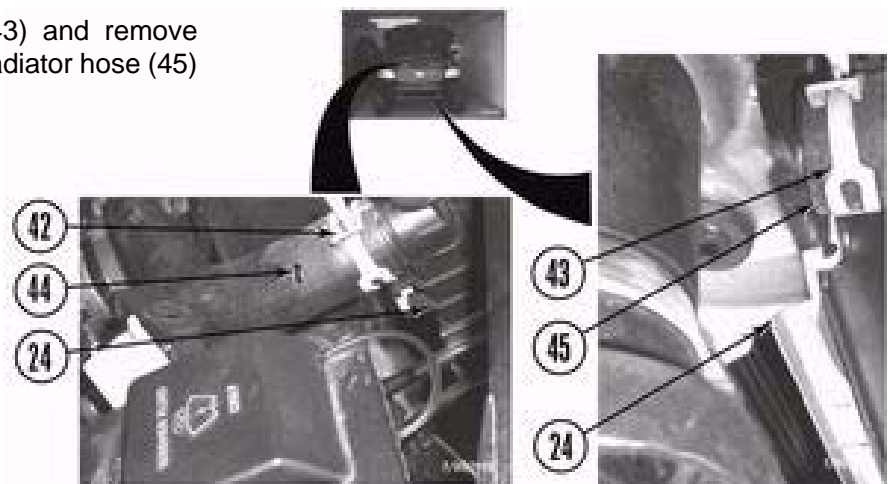

o. Remove two bolts with captive washers (46), four brackets (47 and 48), and radiator (24) from core support (14). Set radiator aside.

p. Remove fan shroud (22) from vehicle and set aside.



q. Remove clip (49) from lines (50 and 51). Clip will not be reused.

r. Loosen nut (52) from stud (53) so bracket (54) moves freely.

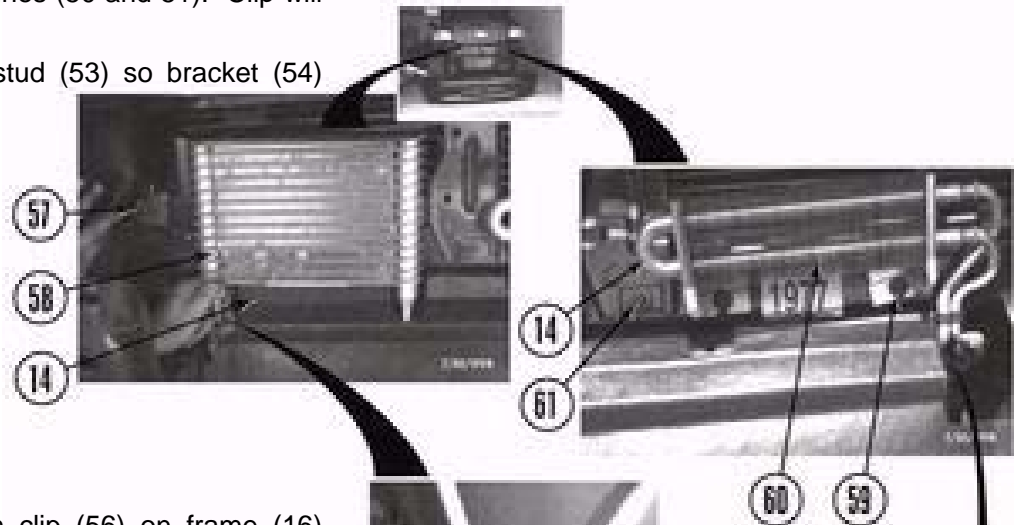

s. Remove line (55) from clip (56) on frame (16) driver side.

t. Remove three screws (57) and transmission cooler (58) from the core support (14).

u. Remove two screws (59) and power steering cooler (60) from the core support (14).

v. Remove bolt (61) from the core support (14).

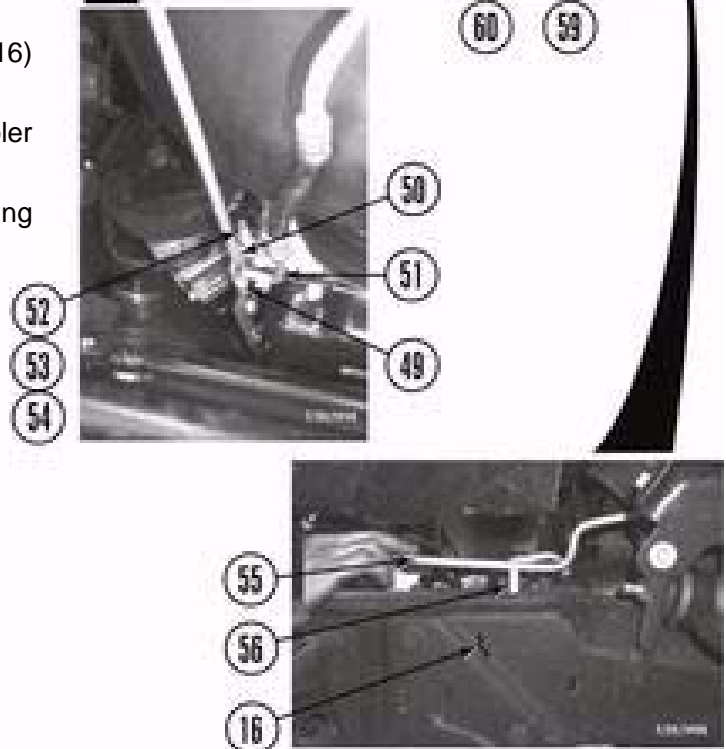

4. Along the frame rails.

a. Remove line (55) from clip (62) on frame (16) driver side.

b. Remove clip (63) and line (55) from frame (16) driver side.

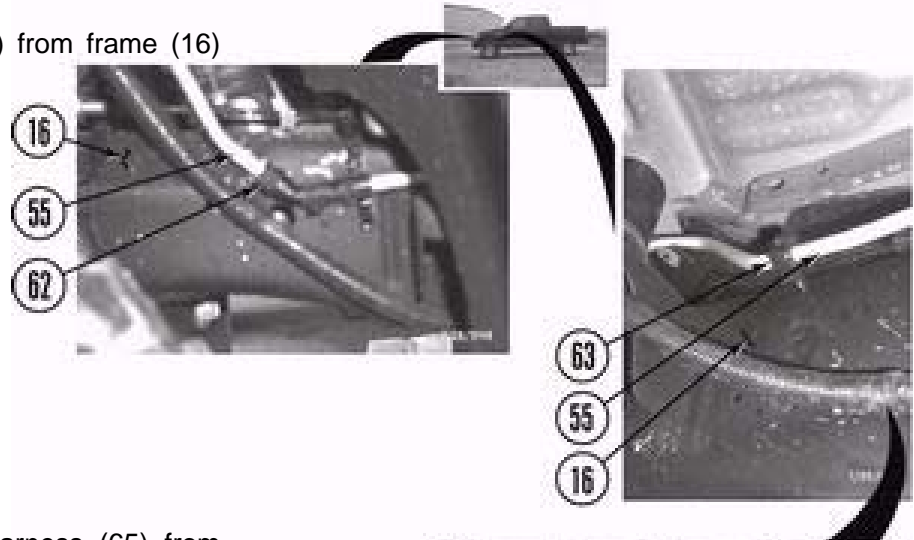

c. Remove two clips (64) and harness (65) from frame (16) driver side.

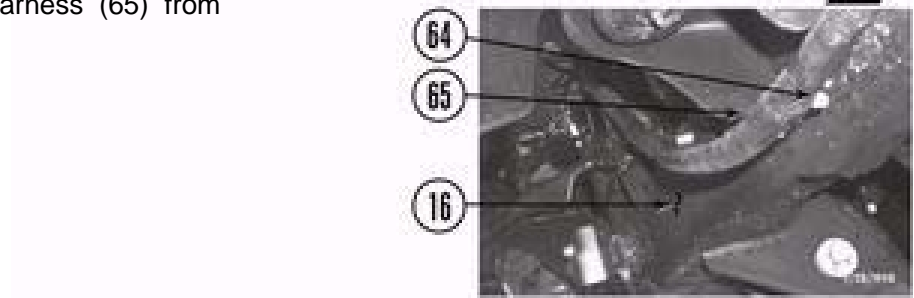

d. Remove bolt (66) and safety cable (67) from frame (16) driver side.

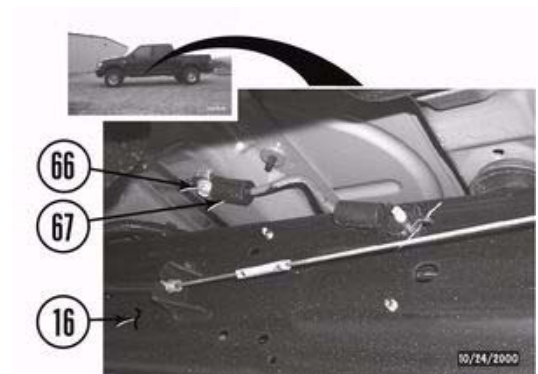

e. Remove bolt (68) and bracket (69) from frame (16) passenger side.

f. Remove screw (70) and ground strap (71) from frame (16) passenger side.

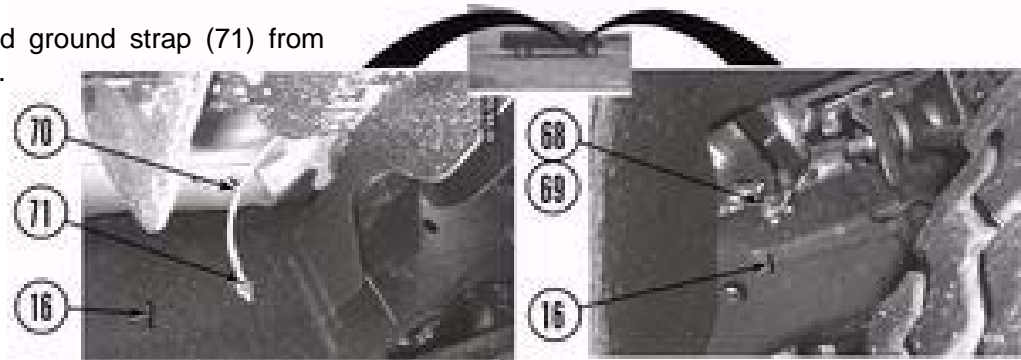

g. Remove bolt (66) and safety cable (67) from frame (16) passenger side.

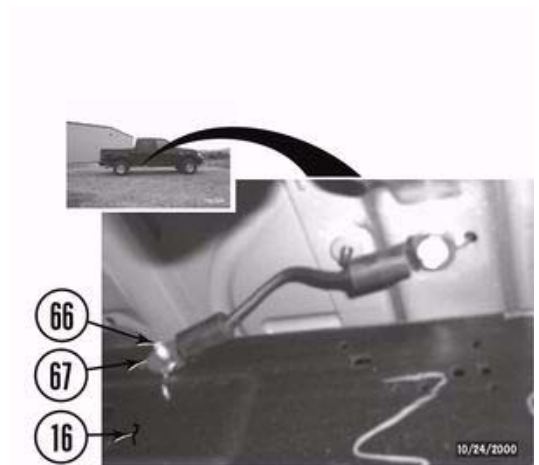

NOTE
Step 5 is for automatic transmission/4.6 liter engine models only. Other models skip this step.

5. Under the cab.

a. Remove two bolts (72) and shift cable bracket (73) from transmission (74).

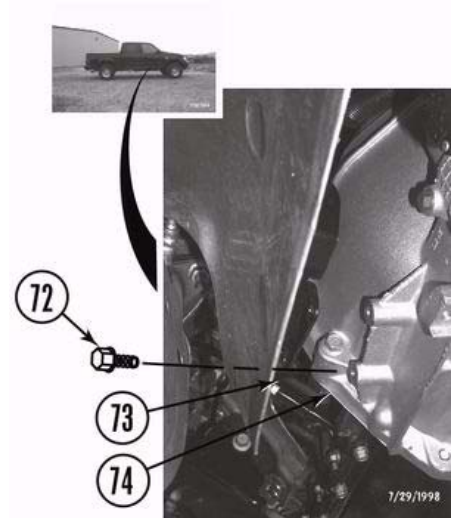

6. Inside the cab.

▲NOTE

Ensure steering shaft does not turn independently of the steering gearbox. This could cause the air bag system to malfunction, resulting in serious personal injury or damage to the equipment.

- a. Straighten steering wheel and strap the wheel so it will not turn.
- b. Loosen bolt (75) from the steering u-joint (76) under the dash, slide u-joint down to remove from steering wheel shaft (77).

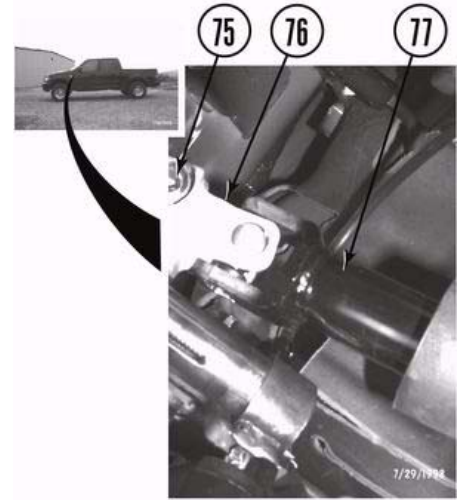

- c. Remove two scuff plates (78) and two kick panels (79) from front of cab floor (80).

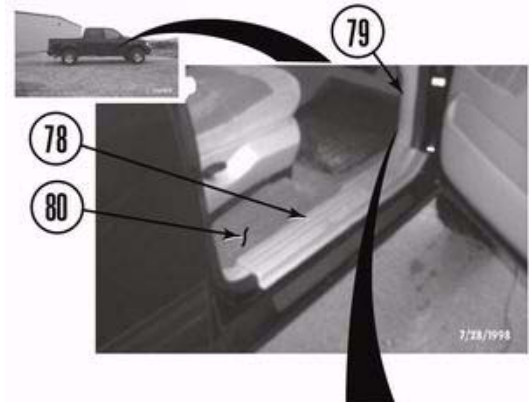

- d. Pull carpet (81) away and remove two rubber caps (82) from front of cab floor (80).

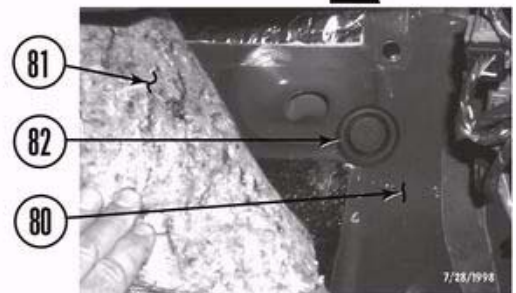

e. Remove two scuff plates (83) and three covers (84 and 85) from rear of cab floor (80).

f. Remove two bolts (86) and rear seatbelt tiedowns (87) from rear of cab floor (80).

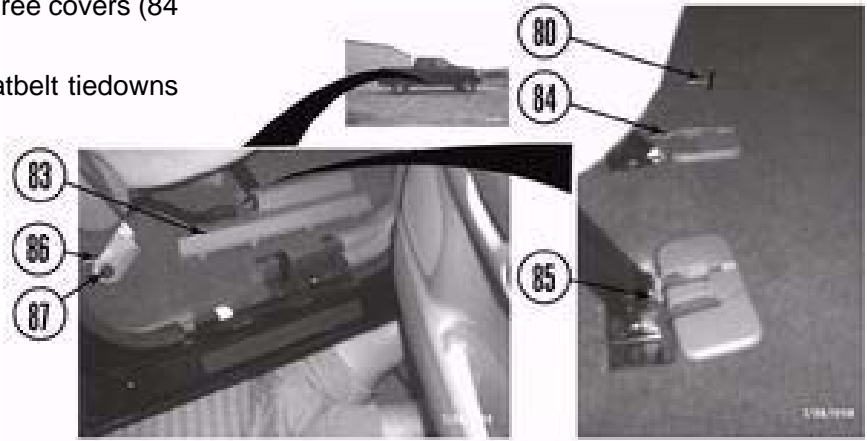

g. Reach under carpet (81) and locate two bolts (88). It's a squeeze, but carpet can be "tented" and bolts removed from rear of cab floor (80) without further carpet removal.

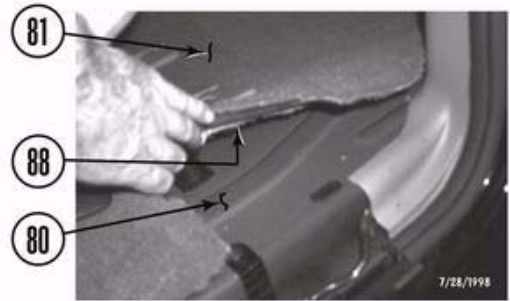

h. Fold rear seats (89) forward and remove four nuts (90), (two from each side) from studs (91).

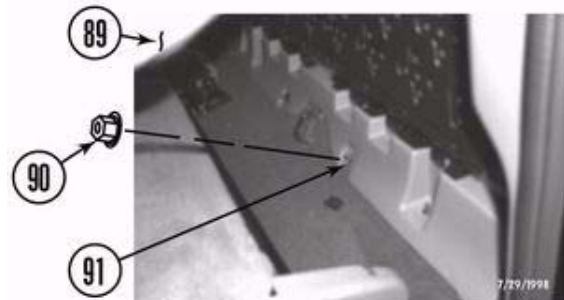

NOTE
Step 6. i. is for automatic transmission/5.4 liter engine usually. Sometimes the 4.6 liter engines have this transmission too and there's no consistency. Sorry.

i. Remove nut (92) and shift cable (93) from stud (94) under the dash. Cable will slide through floor of cab when cab is lifted.

NOTE
Step 6. j. is for manual transmission vehicles only. Other models skip this step.

j. Ensure shifter is in neutral before lifting the cab.

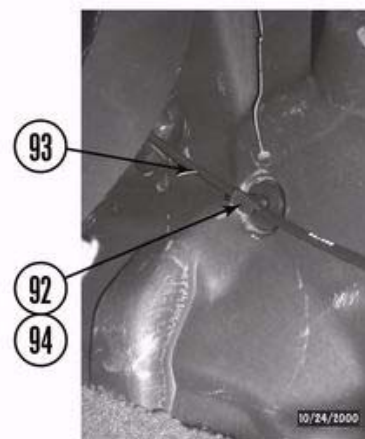

NOTE

Step 6. k through 6. n are for 4wd vehicles only. Other models skip these steps.

k. Remove four screws (95) and outer shift boot (96) from inner housing (97). Pull boot up and out of way.

l. Remove four bolts (98) and inner shift boot (99) from cab floor (80). Pull boot up through hole in carpet (81) and out of way.

m. Remove bolt (100) and transfer case shift lever (101) from linkage (102).

n. Carefully remove two shift boots (96 and 99) from transfer case shift lever (101).

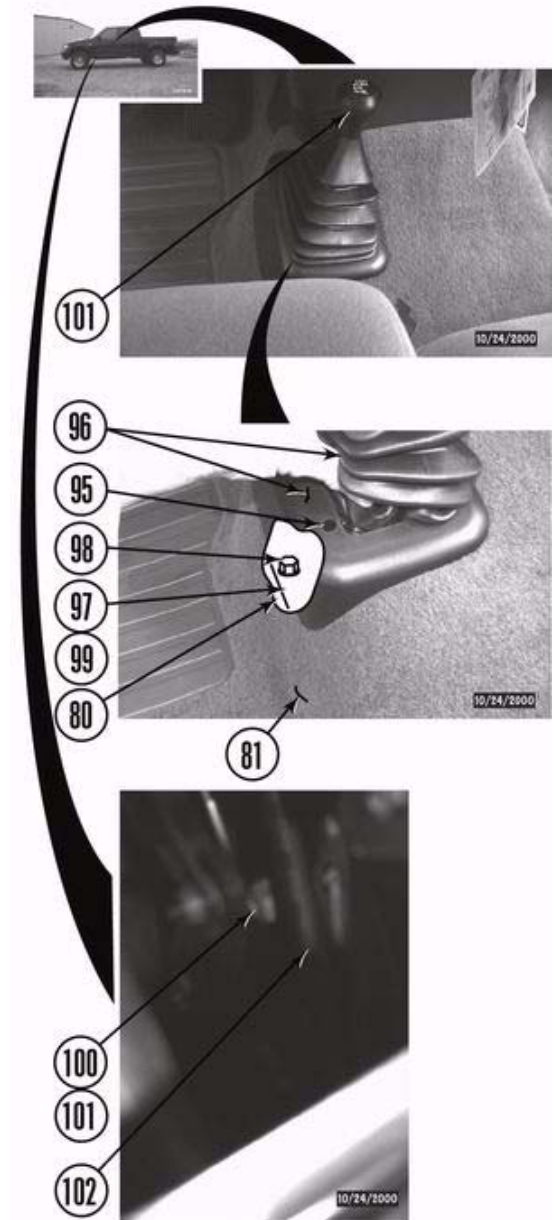

⚠WARNING

Use extreme caution when working near fuel lines and fuel tank. Clean up spilled fuel immediately. Any spark could cause an explosion or fire resulting in serious personal injury and property damage.

7. Remove the fuel filler.
 - a. Remove gas cap (102).
 - b. Remove three bolts (103) from bed (104) and fuel filler (105).

- c. Remove clamp (106) from fuel filler (105) and tongue (107) and let fuel filler neck drop down from the bed (104).

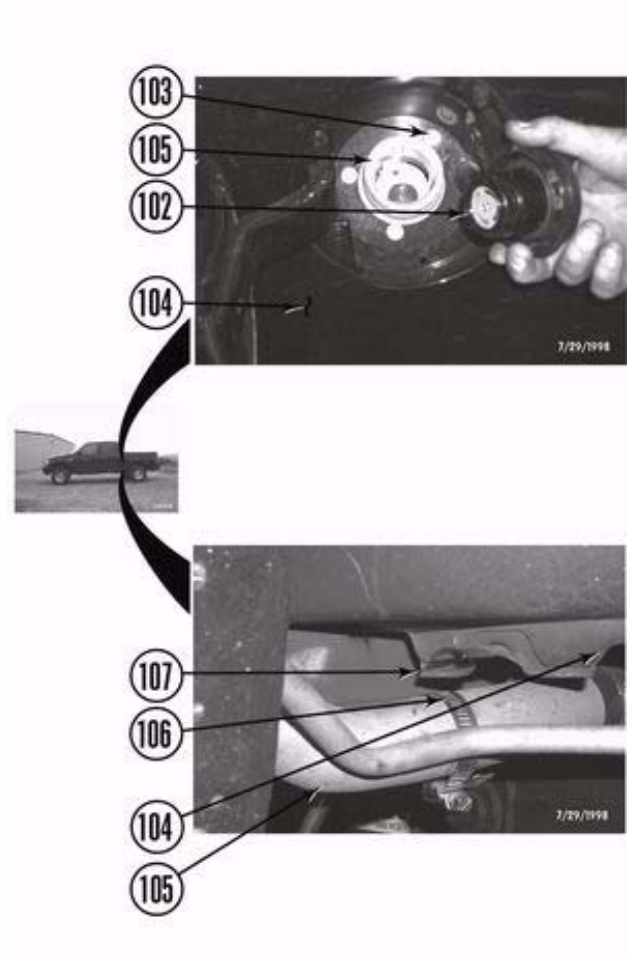

C. Install the kit.

1. Prepare to lift cab from frame.

⚠WARNING

Failure to replace the OEM body mounting hardware (except mounting bolts in the kit) in the stock locations could result in serious personal injury or damage to the vehicle.

- a. Measure distance between the cab (108) and the bed (104). Record measurement for later cab to bed alignment reference in these instructions.

⚠NOTE

Ford uses an extremely cohesive thread locker on cab and bed mounting bolts. This is no problem on the bed and core support mounting points, but the six cab mounting bolts screw into the lower bushings and with the thread locker these are difficult to remove. You will need a friend with a big pair of channel locks to hold the lower bushings while you unscrew the cab mounting bolts. You will encounter much resistance from the thread locker the whole time you are turning the bolts, and air tools really don't work well on this application.

⚠NOTE

You need a T-55 Torx head socket to remove the bed mounting bolts.

- b. Remove six bed mounting bolts (109) from bed (104) and frame (16).
- c. Slide bed (104) back from cab (108) approximately 1". Ensure fuel filler (105) does not hang up on bed.
- d. Hold nuts (110) and loosen but do not remove two cab mounting bolts (111) from core support mounting pad (112) and passenger side frame mounting pad (113).
- e. Hold bottom bushings (114 & 177) and loosen but do not remove six cab mounting bolts (115, 116, and 117) (see next page for locations).

⚠WARNING

Use extreme caution when lifting body from frame. Ensure lifting device is securely placed. Keep hands out from between frame and body, or serious personal injury could result.

⚠CAUTION

Continually check hoses, wires, lines, etc. to be sure that everything is flexing properly and not binding, or damage to the vehicle could result. Be especially careful of the a/c hoses at the firewall, the belt pulley, and at the core support. Ensure brake lines stretch while lifting. Bending the lines to gain ample slack may be necessary. Be extremely careful not to kink the lines.

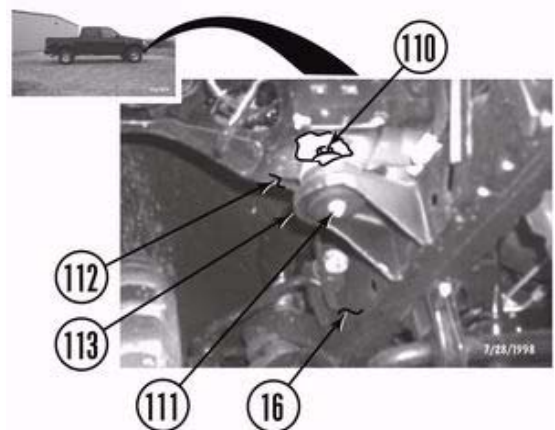
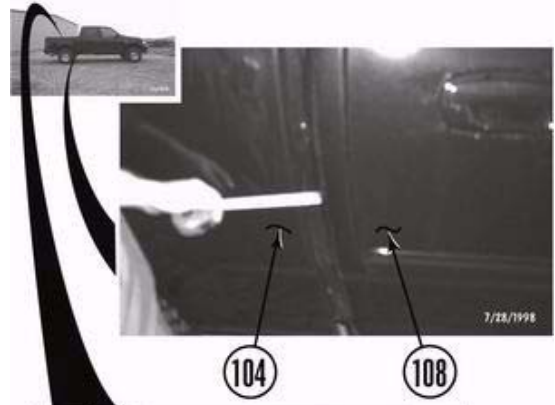

NOTE

Ensure stock spacers and body mounting pads stay on vehicle unless otherwise specified in these instructions. Kit spacer blocks are installed in addition to the stock spacers and body mounting pads.

f. Remove bolt with captive washer (111), bottom bushing (177), nut (110), and washer (118) from the passenger side core support mounting pad (112) and passenger side frame mounting pad (113).

g. Remove bolt with captive washer (115) and bushing (114) from the passenger side frame mounting pad (113) and cab mounting pad (119).

h. Slide ratchet under carpet (81) and remove bolt with captive washer (116) and bushing (114) from the passenger side frame mounting pad (113) and cab mounting pad (119).

i. If necessary, fold rear passenger seat forward. Open door (120) and remove jack and jack handle.

j. Pull plastic (121) forward and remove bolt with captive washer (117) and bushing (114) from the passenger side frame mounting pad (113) and cab mounting pad (119).

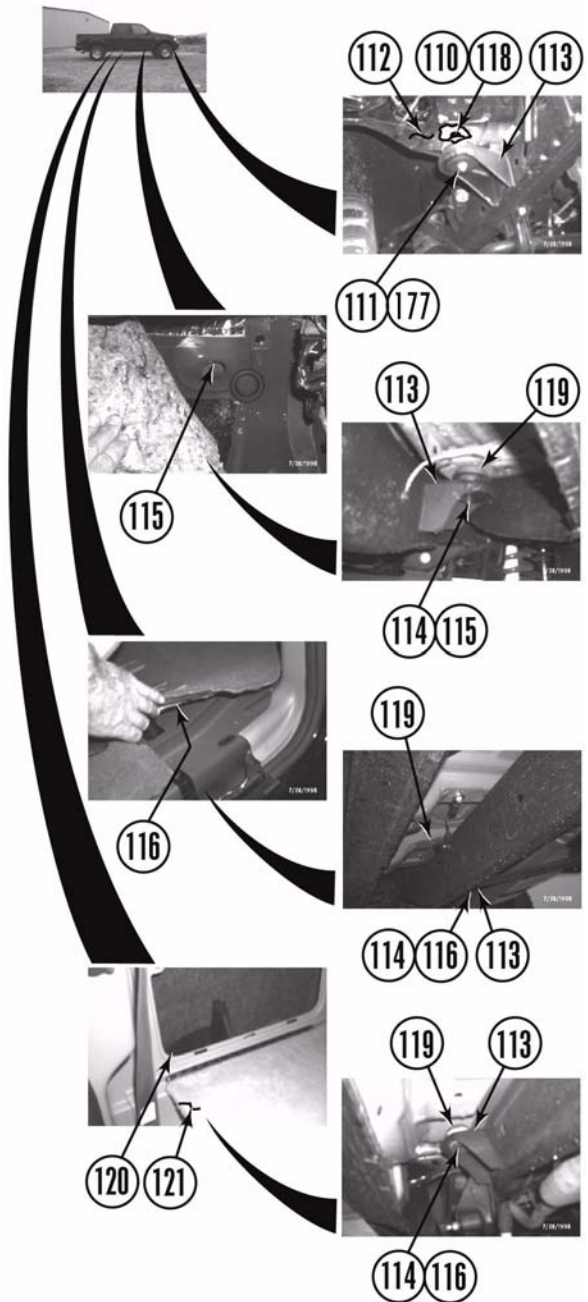

2. Lift cab and install cab passenger side spacer blocks.
 - a. Using a hydraulic jack and a wooden block, slowly lift the cab (108) passenger side just high enough to position the *kit* spacer blocks (122) between the core support mounting pads (112) and frame mounting pads (113).

⚠ CAUTION
ONLY DRILL OUT FRONT CORE SUPPORT UPPER AND LOWER BUSHINGS as directed in the following procedure. Core support mounts are forward most cab mounts. Drilling any other cab mount bushings will not allow for proper installation of kit.

- b. Using a 1/2" drill bit, drill the threads out of the core support top and bottom bushings (176 & 177) ONLY.
 - c. Position four *kit* spacer blocks (122) on top of the passenger side frame mounting pads (113).
 - d. Install a *kit* 12 x 1.75 x 180mm bolt (124) and *kit* 7/16" USS washer (125) through the bottom bushing (177), frame mounting pad (113), top bushing (176), *kit* spacer block (122), cab passenger side core support mounting pad (112), washer (118) and *kit* 12mm nylock nut (110). Do not tighten.
 - e. Install a *kit* 12 x 1.75 x 140mm bolt (126) and *kit* 7/16" USS washer (125) through the cab floor (80), *kit* spacer block (122), top bushing (123), frame mounting pad (113), and bottom bushing (114). Do not tighten.
 - f. Install a *kit* 12 x 1.75 x 140mm bolt (126) and *kit* 7/16" USS washer (125) through the cab floor (80), *kit* spacer block (122), top bushing (123), frame mounting pad (113), and bottom bushing (114). Do not tighten.
 - g. Install a *kit* 12 x 1.75 x 200mm (127) and *kit* 7/16" USS washer (125) through the cab floor (80), *kit* spacer block (122), top bushing (123), frame mounting pad (113), and bottom bushing (114). Do not tighten.
 - h. Lower cab (108) on the *kit* spacer blocks (121).
3. Install the cab driver's side spacer blocks.
 - a. Repeat steps C. 1. F. through j. and C. 2. a. through h. for the cab driver's side, ensuring harness (65) (see step B. 4 c.) goes behind spacer block (122) behind wheel well.
4. Finish the cab spacer block installation.
 - a. Adjust cab to bed clearance using the measurements from step C. 1. a.
 - b. Remove eight bolts (124, 126, and 127) one at a time, coat threads with Loctite®, and install. Tighten to 55 lb-ft.

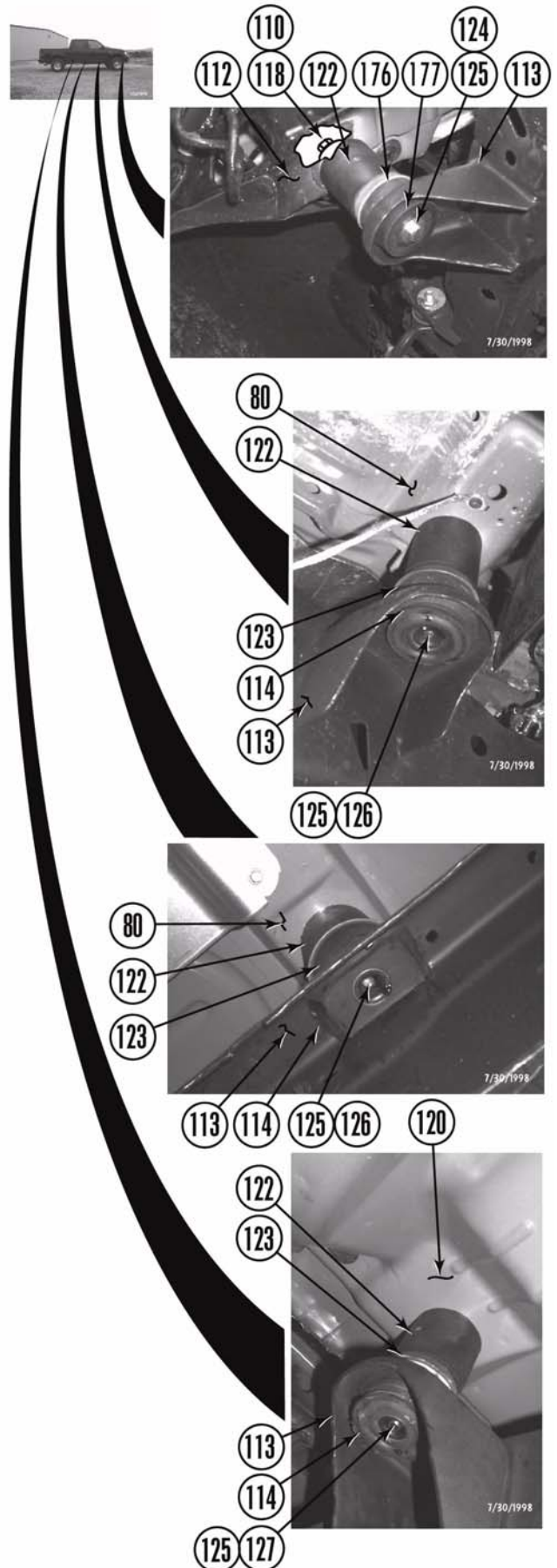

5. Install the bed passenger's side spacer blocks.
 - a. Slide the bed (104) back toward the cab (108) approximately 1".
 - b. Lift the bed (104) passenger's side just high enough to position three *kit* spacer blocks (122) on the frame mounting pads (113).
 - c. Install three *kit* 12mm x 1.75 x 180mm bolts (128) and *kit* 1 3/4" thick washers (129) through the bed (104), *kit* spacer blocks (122), and the frame mounting pads (113). Do not tighten.
 - d. Lower the bed onto the spacer blocks (122).
6. Install the bed driver's side spacer blocks.
 - a. Repeat steps C. 5 a. through d. for the bed driver's side.
7. Finish the bed spacer block installation.
 - a. Adjust the cab to bed clearance using the measurements from step C. 1. a.
 - b. Remove six bed mounting bolts (128) one at a time, coat threads with Loctite®, and reinstall. Tighten to 55 lb-ft.

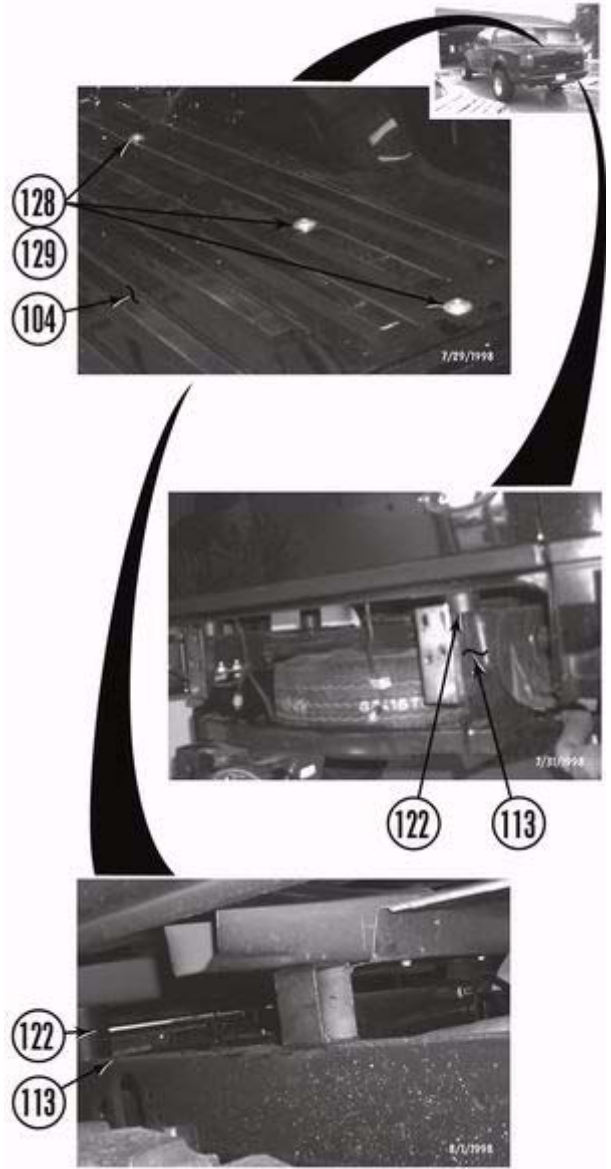

8. Inside the cab.
9. Install the steering extension.
 - a. Position *kit* steering extension (130) in the steering u-joint (76) and tighten bolt (75).
 - b. Slide *kit* steering extension (130) up onto steering wheel shaft (77). Ensure steering wheel has not turned and tighten *kit* bolt (131).

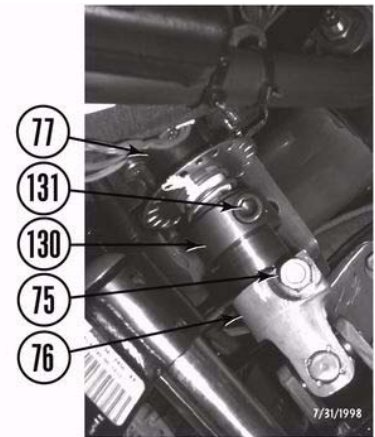

NOTE

Steps 9 c. and d. are for moveable pedal vehicles only. Other models skip these steps.

- c. Grasp brake pedal (132) and push to the left enough to bend pedal mounting bracket (133) *slightly*.
- d. Operate pedal button (134). Ensure when brake pedal (132) is all the way forward against firewall pedal does not contact steering u-joint (76) or solenoid (135).

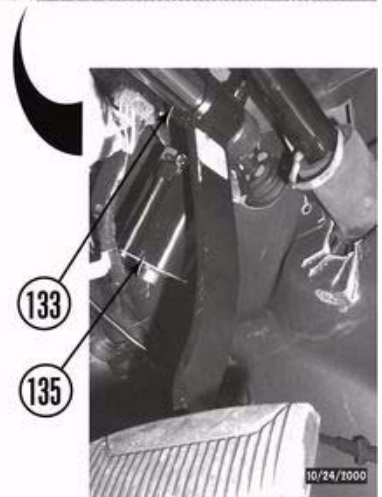
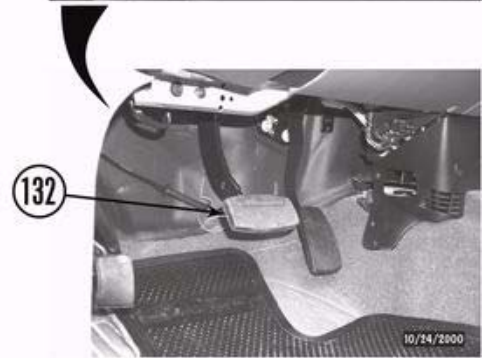

⚠WARNING

Be careful not to damage any of the parts attached to the shift levers during cutting and welding or damage to the equipment could result. A certified welder should perform all welding.

⚠NOTE

Steps 10 a. through f. are for 4wd vehicles only. Other models skip these steps.

10. Lengthen and install the transfer case shift lever.

- a. Scribe a line along the side of the transfer case shift lever (101) (below the bend) as shown. Cut the lever into two pieces through the line and deburr as necessary.
- b. Position *kit* transfer case shift lever extension (136) between the two pieces of the transfer case shift lever (101). Ensure the extension and lever scribed lines align and weld the extension in place.
- c. Slide outer shift boot (96) and inner shift boot (99) on transfer case shift lever (101).
- d. Install transfer case shift lever (101) on linkage (102) with bolt (100). Check transfer case shift lever operation.

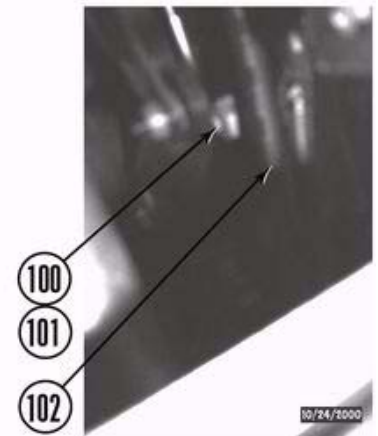
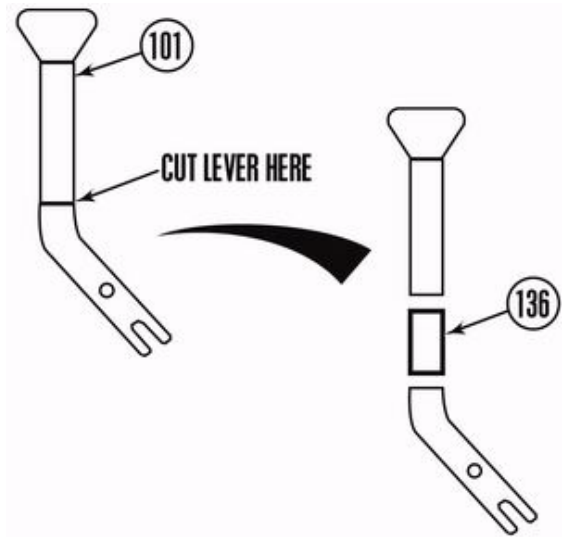

- e. Position inner shift boot (99) through hole in carpet (81) and install on cab floor (80) with four bolts (98).
- f. Install outer shift boot (96) on cab floor (80) with four screws (95).

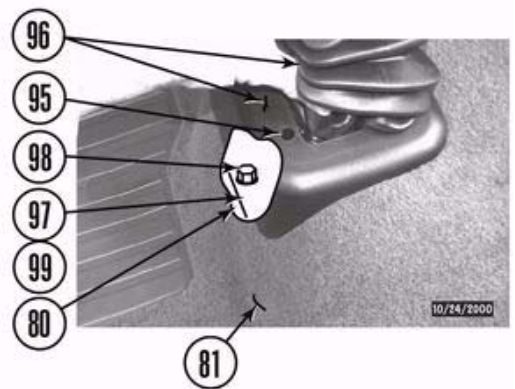

- g. Install jack and jack handle and close door (120).

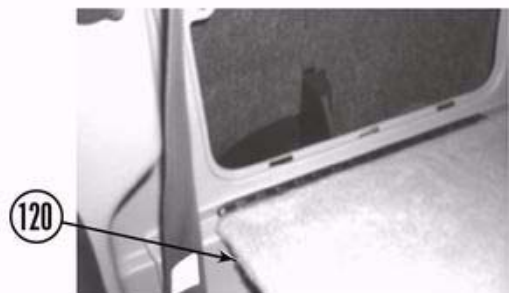

h. Install four nuts (90) on studs (91).

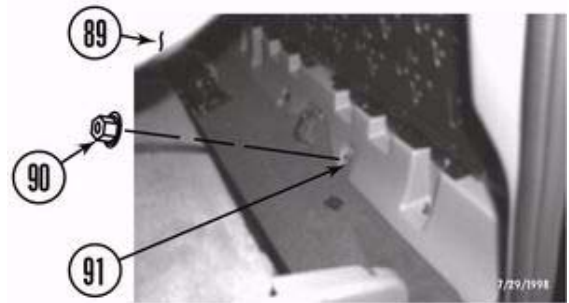

i. Fold rear seats (89) back and install two rear seat-belt tiedowns (87) in cab floor (80) with two bolts (86).

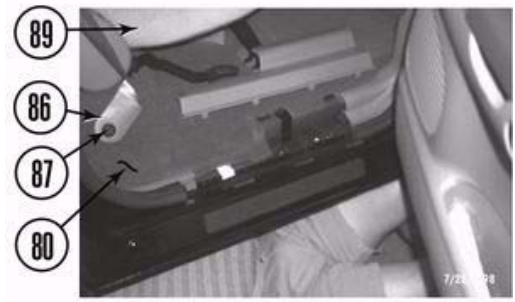

j. Smooth carpet (81) to its original position and install three covers (84 and 85) and two scuff plates (83) on rear of cab floor (80).

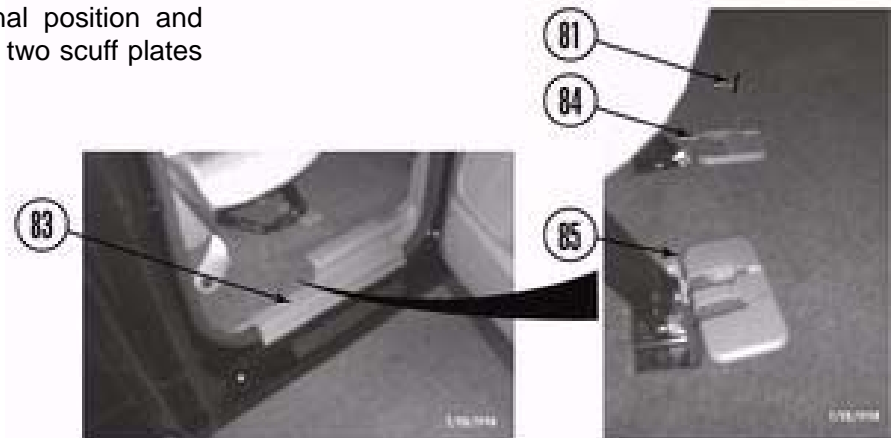

k. Install two rubber caps (82) in front of cab floor (80).

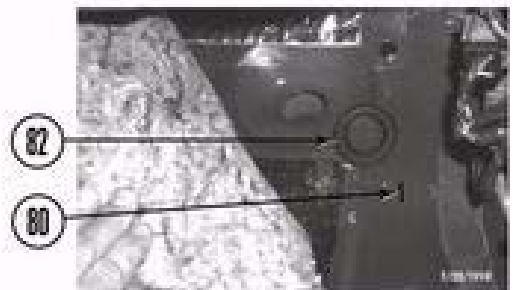

I. Smooth carpet (81) into corners of cab floor (80) and install two kick panels (79) and two scuff plates (78).

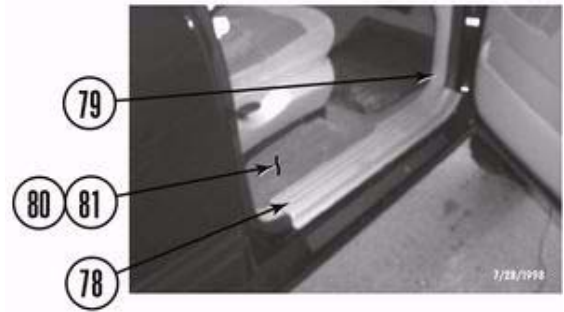

11. Under the cab.

a. Check the parking brake cable (137) to ensure it slid down through the grommet (138) in the cab floor (80). Ensure grommet is correctly positioned in cab floor.



NOTE
Steps 11. a. through 11. c. are for automatic transmission/4.6 liter engine models only. Other models skip these steps.

b. Install *kit* bracket (139) on transmission (74) with two bolts (72).
c. Install shift cable bracket (73) on *kit* bracket (139) with two kit 5/16 x 1" bolts (140), four 5/16" washers (141), and two 5/16" nylock nuts (142).

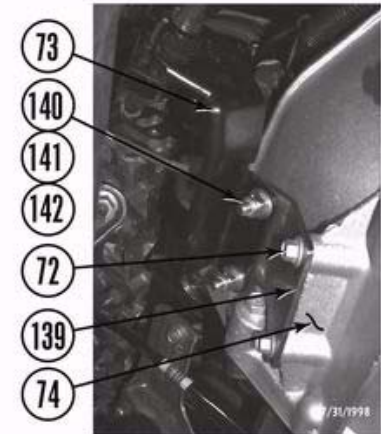

d. If the transmission shift indicator pointer on the column is now off, adjust it using the wheel (143) under the dash until the pointer points correctly to all shift ranges.

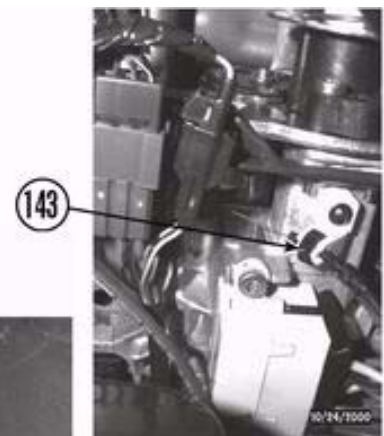

NOTE
Steps 11. d. is for automatic transmission/4.6 liter engine models only. Other models skip this step.

e. Slide nut (92) up shift cable (93) and install on stud (94).

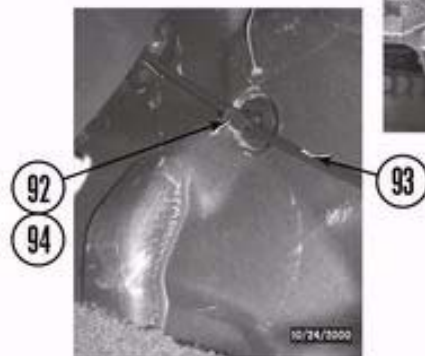

⚠WARNING

Use extreme caution when working near fuel lines and fuel tank. Clean up spilled fuel immediately. Any spark could cause an explosion or fire resulting in serious personal injury and property damage.

12. Install fuel filler.

- a. Remove two clamps (106 and 144), filler hose (145), and vent hose (146) from gas tank (147).
- b. Remove two clamps (106 and 144) and fuel filler (105) from filler hose (145) and vent hose (146).

- c. Cut filler hose (145) in half as shown.
- d. Install half of filler hose (145), *kit* filler hose extension (148), and other half of filler hose (145) on fuel filler (105) with three *kit* #28 clamps (149).
- e. Install *kit* vent hose (150) on fuel filler (105) with *kit* #10 clamp (151).

- f. Install *kit* vent hose (150) and filler hose (145) on gas tank (147) with two clamps (106 and 144).

- g. Install fuel filler (105) on tongue (107) with clamp (106).

- h. Install fuel filler (105) on the bed (104) with three bolts (103).

- i. Install gas cap (102).

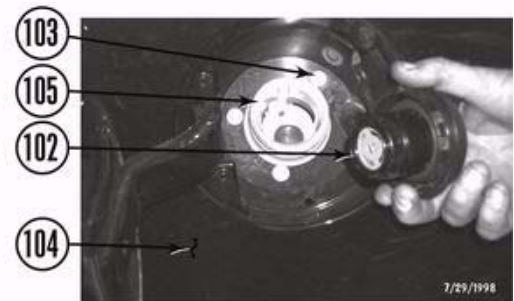
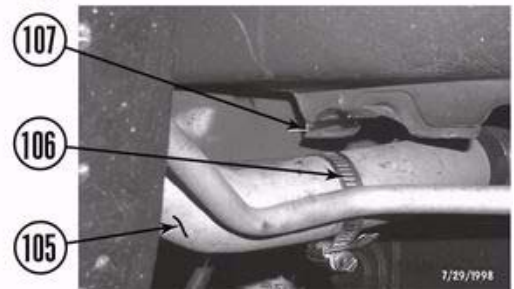
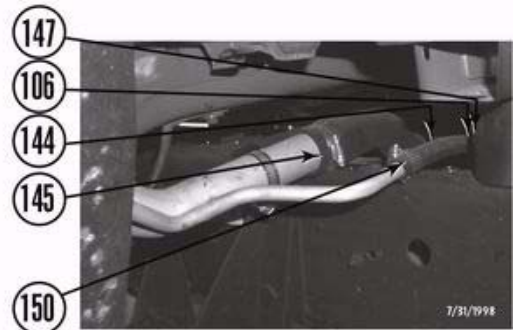
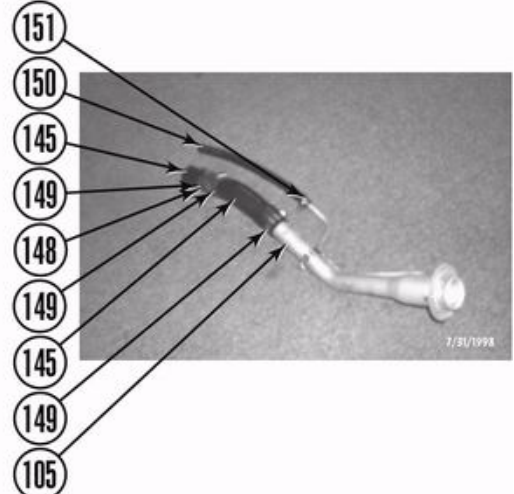
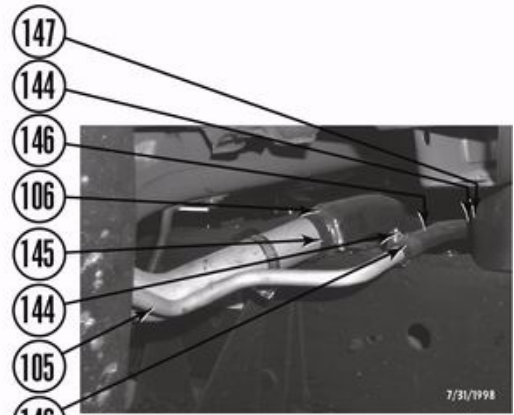

13. Along the frame rails.

a. Measure 1" forward of the holes on each side of the frame (16) from which you removed the bolts (66) and safety cables (67).

b. Mark and drill a 1/2" hole on each side. Ensure the drill does not contact fuel and brake lines inside the frame (16).

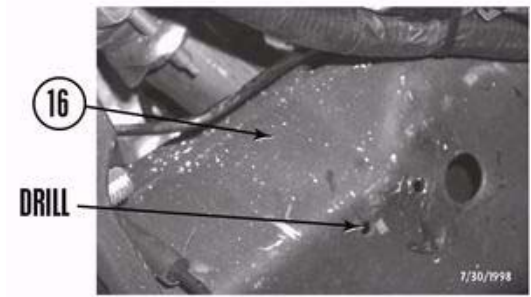

c. Install safety cable (67) in new hole in the frame (16) driver side with bolt (66).

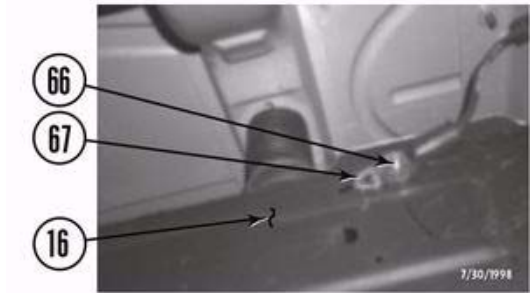

d. Secure harness (65) to hard line (55) with two *kit* zip ties (151).

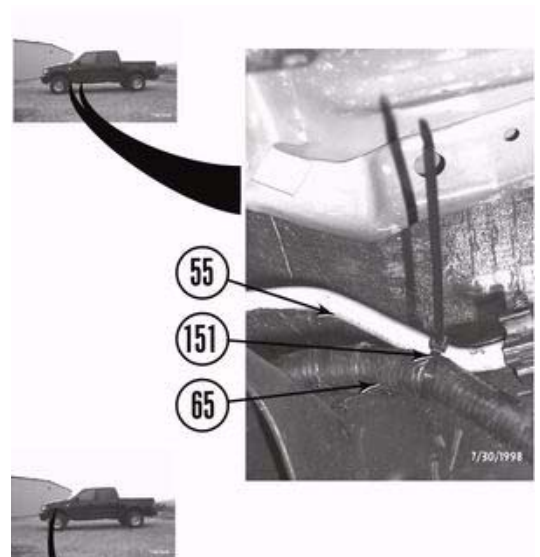

e. Ensure there is enough slack in line (152) though grommet (153) on driver side shock tower (154) so wheel travel will not break line. If line does not have enough slack, pull some line through grommet towards wheel.

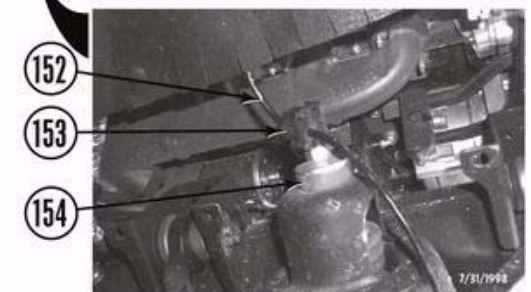

f. Install safety cable (67) in new hole in the frame (16) passenger side with bolt (66).



g. Install *kit* bracket (155) on frame (16) passenger side with bolt (70).

h. Install ground strap (71) on *kit* bracket (155) with *kit* 1/4 x 1" bolt (156), two *kit* 1/4" SAE washers (157), and *kit* 1/4" nylock nut (158).

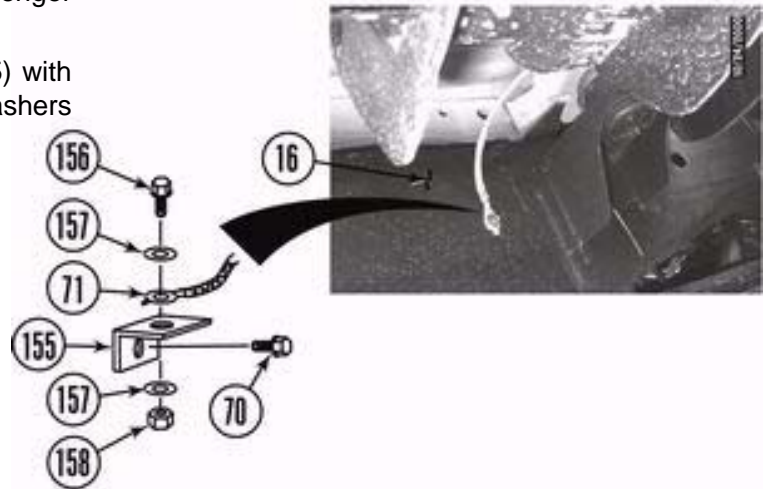

i. Install *kit* bracket (159) on frame (16) passenger side with bolt (68).

j. Bend bracket (69) 90 degrees as shown and install on *kit* bracket (159) with *kit* 1/4 x 1" bolt (156), two *kit* 1/4" SAE washers (157), and *kit* 1/4" nylock nut (158). Ensure negative battery cable (160) will reach battery (3).

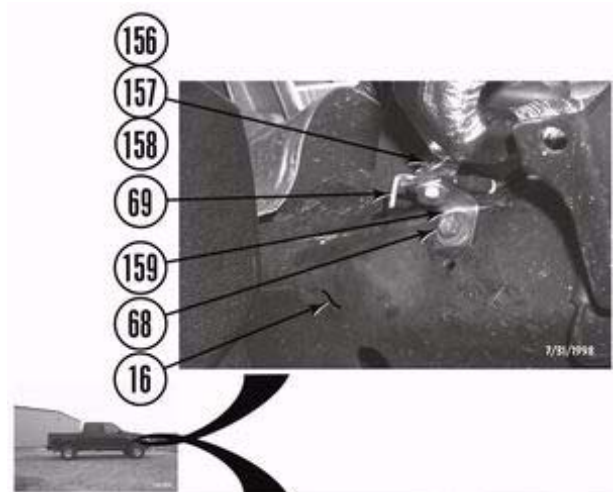

k. Ensure there is enough slack in line (161) through grommet (162) on passenger side shock tower (163) so wheel travel will not break line. If line does not have enough slack, pull some line through grommet towards wheel.



14. Under the hood.

a. Cut top click-in mounting tabs (25) and lower mounting tabs (164) off of the fan shroud (22).

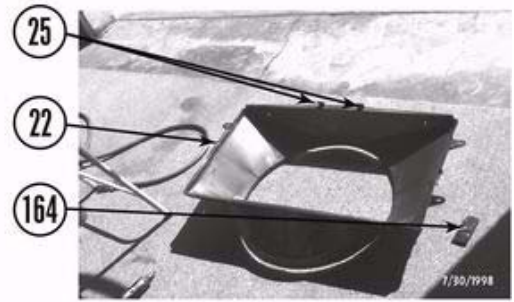

b. Position fan shroud (22) in vehicle and rest on fan.

c. Install radiator (24) and four brackets (47 and 48) on core support (14) with two bolts with captive washers (46).



d. Squeeze two clamps (42 and 43) and install upper radiator hose (44) and lower radiator hose (45) on radiator (24).

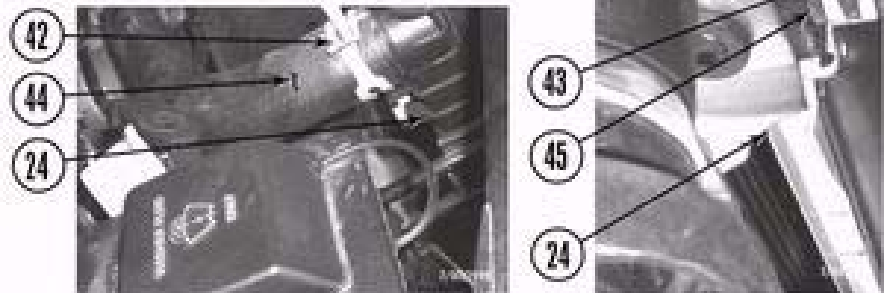

e. If removed, install two automatic transmission cooling lines (40 and 41).

f. Squeeze clamp (38) and install hose (44) on radiator (24).

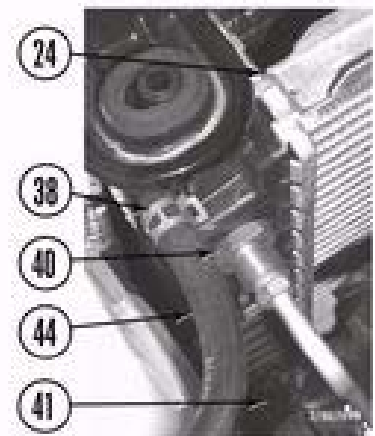

g. Fill radiator (24) and replace radiator cap (36). Radiator must be topped off after vehicle is started.



h. Install two *kit* fan shroud mounting brackets (165) on radiator (24) with two screws (23). Do not tighten.

i. Install fan shroud (22) on *kit* mounting brackets (165) with two *kit* 1/4" SAE washers (157) and *kit* 1/4" nylock nuts (158). Do not tighten.

j. Check fan to fan shroud clearance. Ensure gap is the same all around shroud and tighten screws (23) and nuts (158).

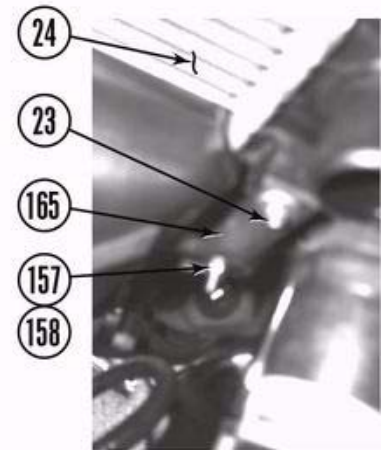

k. Install *kit* lower fan shroud support bracket (166) on core support (14) with bolt (61).

l. Using the *kit* lower fan shroud support bracket (166) as a template, mark and drill a 5/16" hole in the fan shroud (22).

m. Install fan shroud (22) on *kit* bracket (166) with *kit* 1/4 x 1" bolt (156), two *kit* 1/4" SAE washers (157), and *kit* 1/4" nylock nut (158). Ensure bolt (156) threads point out of shroud. Turn fan by hand and ensure fan does not contact fan shroud.

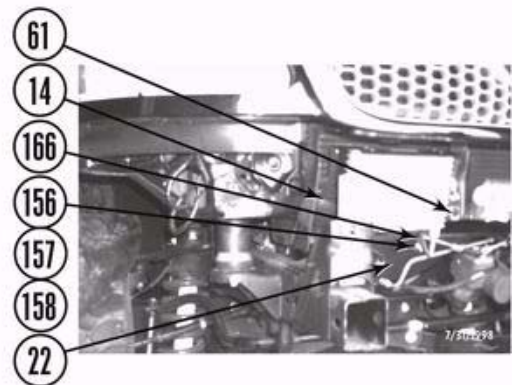

n. Install power steering cooler (60) on core support (14) with two screws (59).



o. Install transmission cooler (58) on core support (14) with three screws (57).



p. Tighten nut (52) and bracket (54) on stud (53).

q. Carefully bend lines (50 and 51) so they clear fan shroud (22) and do not rub on anything.

r. Install lines (50, 51, and 55) in clips (49 and 56) when possible.

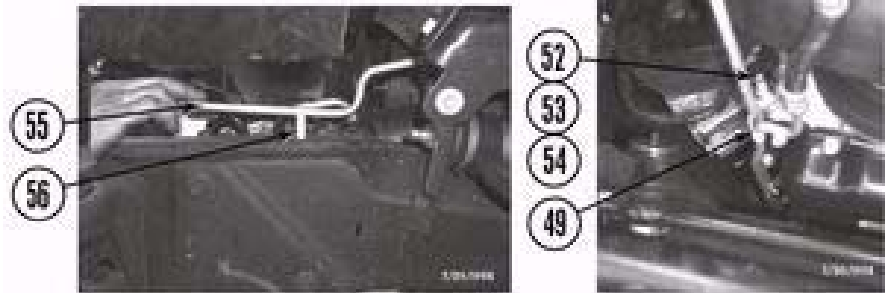

s. Position air duct (30) on air filter housing (33) and tighten clamp (32).



t. Tighten clamp (31) on air duct (32) and throttle body (30).

u. Install two hoses (33) on air duct (32) and throttle body (30).



v. Install cover (29) on throttle body (30) with three screws with captive washers (28).

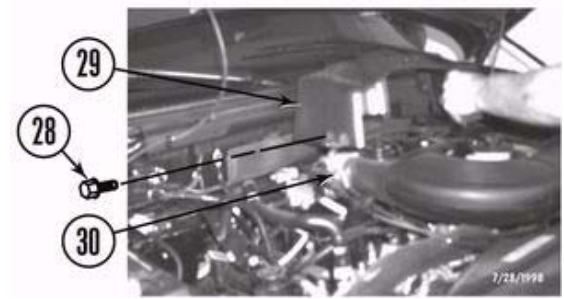

w. Install radiator shroud (21) on core support (14) with seven screws (20).

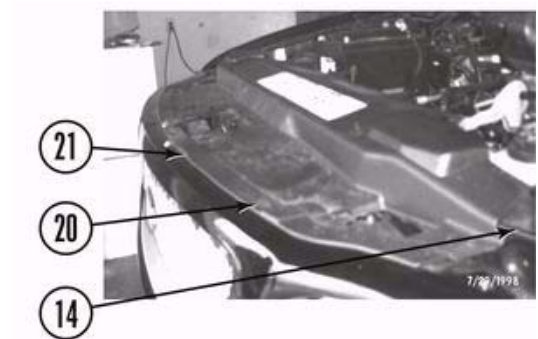

x. Tie radiator shroud (21) on fan shroud (22) with two *kit* zip ties (167).

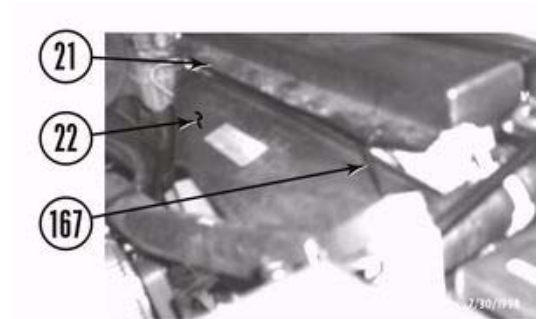

y. Replace spare tire crank (26) in clips (27).

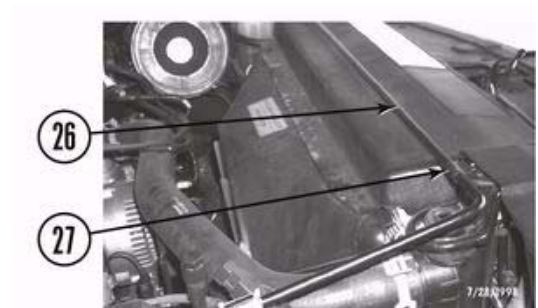

⚠WARNING

The following procedure is intended only to enhance the appearance of the vehicle. The rear bumper will no longer be rated for towing of any kind. Towing with the rear bumper after it has been lifted can result in death, serious personal injury, or damage to the vehicle. Towing after the bumper has been lifted should be accomplished using a rated Class III receiver type hitch.

15. Install the rear bumper.

a. Coat threads of bolts (168) and nuts (19) with Loctite®.

b. Position two *kit* brackets (169) on frame (16) and install two *kit* 7/16 x 1 1/2" bolts (168), four *kit* 7/16" USS washers (170), and two *kit* 7/16" nylock nuts (171). Hand tighten.

c. Mark frame (16) in center of holes in *kit* brackets (169) as shown. Remove *kit* brackets from frame.

d. Drill two holes in frame (16) as shown. Elongate holes horizontally for bumper adjustment.

e. Position two *kit* brackets (169) on frame (16) and install four *kit* 7/16 x 1 1/2" bolts (168), eight *kit* 7/16" USS washers (170), and four *kit* 7/16" nylock nuts (171). Do not tighten.

f. Position rear bumper (18) on kit brackets (169) and install four nuts (19). Do not tighten.

g. Adjust bumper to body clearance and tighten bolts (168) and nuts (19) to 55 lb-ft.

h. Connect two license plate lights (17) in rear bumper (18).

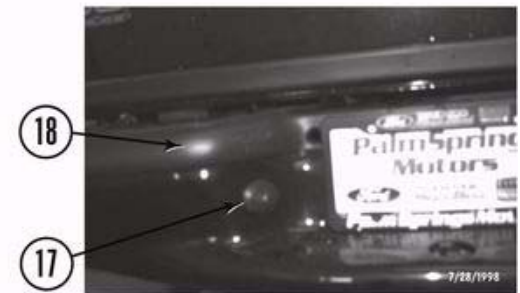
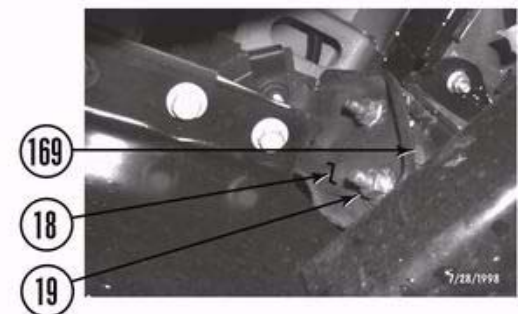
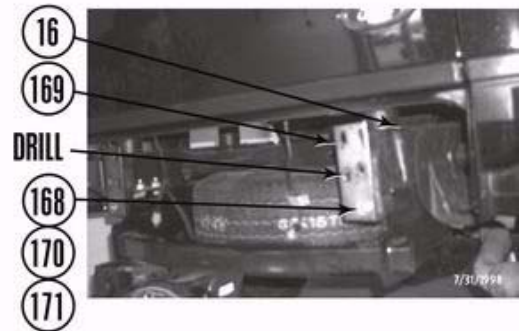

16. Install the front bumper.

a. Cut material from the front frame horns (172) as shown. Remove enough metal so bottom of bumper will clear.

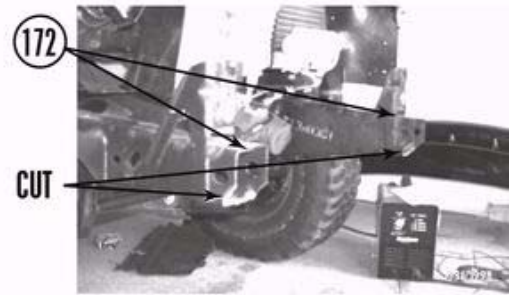

b. Coat threads of bolts (173) and nuts (15) with Loctite®.

c. Install two *kit* brackets (174) on frame (16) behind stock mounts as shown with two *kit* 7/16 x 1 1/2" bolts (168), four *kit* 7/16" USS washers (170), and two *kit* 7/16" nylock nuts (171).

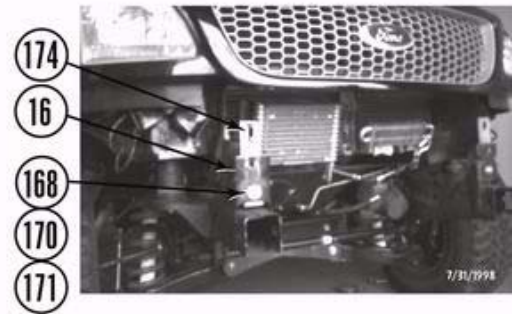

d. Install front bumper (8) on frame (16) and *kit* brackets (174) with four nuts (15). Do not tighten.

e. Adjust bumper to body clearance and tighten bolts (168) and nuts (15) to 55 lb-ft.

f. If removed, connect two connectors (10) on fog lamps (11).

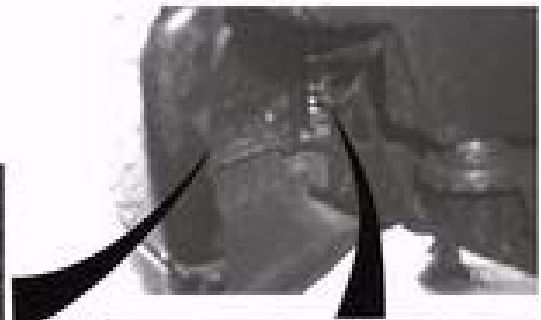

g. Install air flap (11) on front bumper (8) and core support (12) with eight panel clips (10).



⚠CAUTION

A certified welder should perform all welding.

17. Install bed crush blocks.

- a. Weld two *kit* bed overload spacers (175) on the frame (16) over the rear wheel wells as shown.

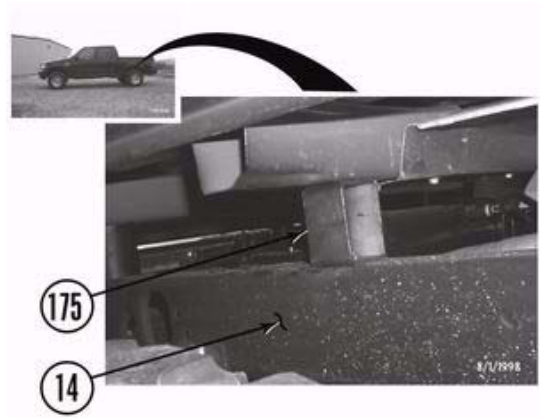

D. After installation is complete.

1. Install airbag fuse (6) in fuse panel (7). Install two covers (4 and 5).



2. Connect both battery cables to the battery (3). Be sure to reconnect the positive cable (2) first, then the negative cable (1).



3. Stick *kit* warning sticker on the dash in plain sight of all vehicle occupants.

4. Double check the vehicle.

⚠CAUTION

Retorque all fasteners after 500 miles and after off road use. All body lift components should be visually inspected and fasteners retorqued during routine vehicle servicing.

- a. Check all mounting hardware to ensure it is properly tightened.
- b. Check all wires, hoses, cables, etc. to ensure they have been properly connected and there is ample slack. With the number of hoses on this vehicle, it is vital that this be checked thoroughly.
- c. Check vehicle electrical system.
- d. Start vehicle and check the steering in both directions to ensure that there is no bind. Check clutch operation. Check the operation of the brake system and the parking brake. Check both shift levers' operation. Ensure that there is proper engagement in all gears and 4 wheel drive ranges.

⚠WARNING

If the engine cooling system is hot, the coolant will be HOT and UNDER PRESSURE. To prevent serious personal injury, wait until the cooling system is completely cool before removing the cap from the radiator.

- e. Check coolant level. Fill coolant to the proper level (refer to the Owner's Manual).
- f. Test drive vehicle in all gears and 4 wheel drive ranges. Pay close attention to all vehicle systems. Check all hardware again in 500 miles and as part of your regular maintenance schedule.

⚠WARNING

Retorque all fasteners after 500 miles and after off road use. All body lift components should be visually inspected and fasteners retorqued during routine vehicle servicing.

⚠CAUTION

Performance Automotive Group does not recommend any particular wheel and tire combinations for use with its body lifts and cannot assume responsibility for the customer's choice of wheels and tires. Refer to your owner's manual for recommended tire sizes and warnings related to the use of oversized tires. Larger wheel and tire combinations increase stress and wear on steering and suspension components, which leads to increased maintenance and higher risk for component failure. Larger wheel and tire combinations also alter speedometer calibration, braking effectiveness, center of gravity, and handling characteristics. Consult an experienced local off road shop to find what wheel and tire combinations work best with your vehicle.

NOTE

All warranty information, instruction sheets, and other documents regarding the installation of this product must be retained by the vehicle owner. Information contained in the instructions and on the warranty card will be required for any warranty claims. The vehicle owner needs to understand the modifications made to the vehicle and how they affect vehicle handling and performance. Failure to provide the customer with this information can result in damage to the vehicle and severe personal injury.

E. Kit Parts List.

Quantity Description

	Kit
14	3 x 3 blocks
2	Front outer bumper brackets
2	Rear bumper brackets
2	Cab spacers without holes
1	1 3/4" gas filler extension
1	16" x 1/2" vent hose
1	Warning to driver sticker
1	Logo sticker
1	6ml bottle Loctite
1	Fan shroud bracket
1	Transmission bracket
1	Bolt pack BP70013
8	12mm x 1.75 x 180mm bolts
2	12mm x 1.75 x 200mm bolts
4	12mm x 1.75 x 140mm bolts
2	12mm x 1.75 nylock nuts
8	7/16" USS washers
6	1 3/4" thick washers
1	se 3000 steering extension
1	3/8" x 1 1/4" socket head bolt
1	Hardware pack HP70013
	Bolts
6	7/16" x 1 1/2" bolts
2	5/16" x 1" bolts
5	1/4" x 1" bolts
	Washers
12	7/16" USS washers
4	5/16" USS washers
12	1/4" SAE washers
	Nuts
6	7/16" nylock nuts
2	5/16" nylock nuts
7	1/4" nylock nuts
	Miscellaneous
1	1/2" shift extension pin
2	3" long stud radiator brackets
2	short L-shaped brackets
1	#10 hose clamp
3	#28 hose clamps
6	Zip ties



Transmission cable bracket

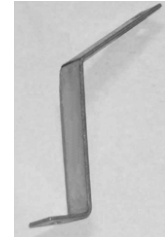

Lower fan shroud bracket

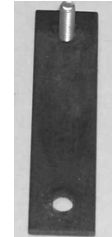

Fan shroud bracket



Front bumper outer bracket



Rear bumper bracket



L-shaped bracket