

INSTALLATION GUIDE

45 minutes
Normal Install Time

Keep an eye out for these icons:

IMPORTANT!
Important installation information

Helpful Hints
Tips to assist installation

PARTS INCLUDED:

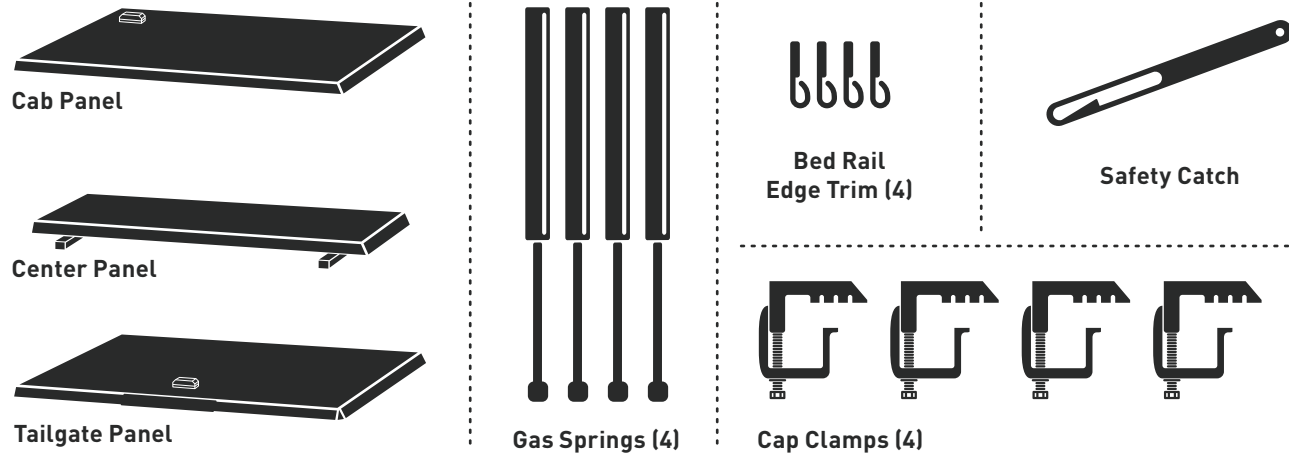

PRE-INSTALLATION NOTES:

1. If your truck has bed rail caps, you should affix the included **bulkhead weatherstrip** prior to installing your DiamondBack. Refer to the **Bulkhead Prep Kit Installation Guide** for details.
2. If you are installing a **cab guard** or **headache rack**, you should mount it prior to mounting your DiamondBack. Refer to its installation guide for details.
3. If you are installing a **Side-Loading ATV Carrier** on cargo bed longer than 6 feet, you must mount the **center panel adapter bars** prior to installing the DiamondBack HD. Refer to the **Side Adapter Bars Installation Guide** for details.
4. It's possible for one person to install a DiamondBack solo, but the whole process, especially positioning the panels and adjusting the lock rods, is much easier with two people.

TOOLS REQUIRED:

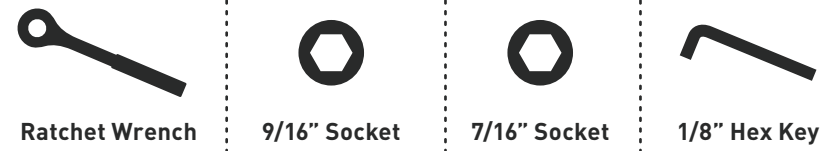

POSITION THE PANELS

1 Place the **center panel** across the center of bed, cheated slightly toward the tailgate.

! Make the sure the arrow sticker on the underside of the center panel is pointing toward the tailgate.

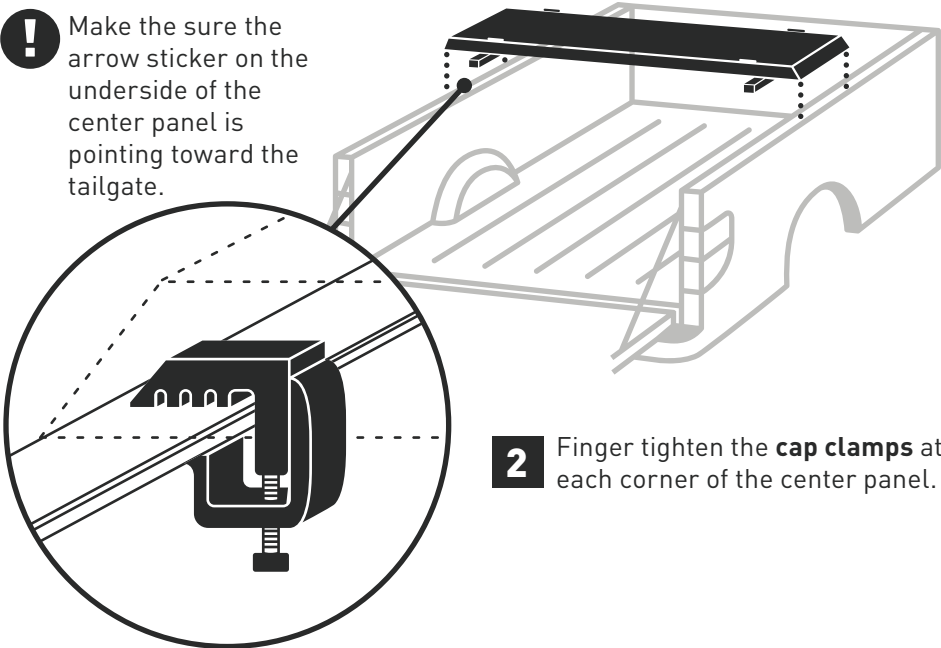

2 Finger tighten the **cap clamps** at each corner of the center panel.

3 Slide the **cab panel** onto the center panel by mating their hinges. Close the cab panel slowly. Make sure it doesn't hit your cab.

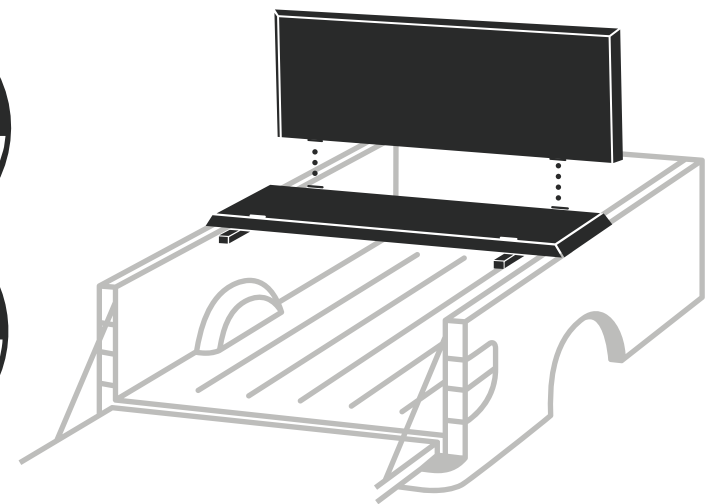
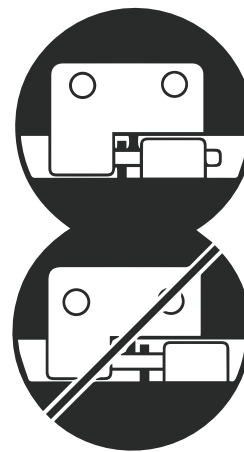

! To avoid hinge damage, do not close the panel until the hinges are fully mated: With the panel tilted more than 90° from its closed position, slide it onto its hinges until the hinge barrels are aligned with the leaves and the locking tabs interlock.

★ Mating hinges is easiest when you line up the longer, left hinge pin first.

4 Repeat step three for the **tailgate panel**.

5 Position the cover front to back so that the leading edge of the cab panel lines up with the leading edge of the bulkhead.

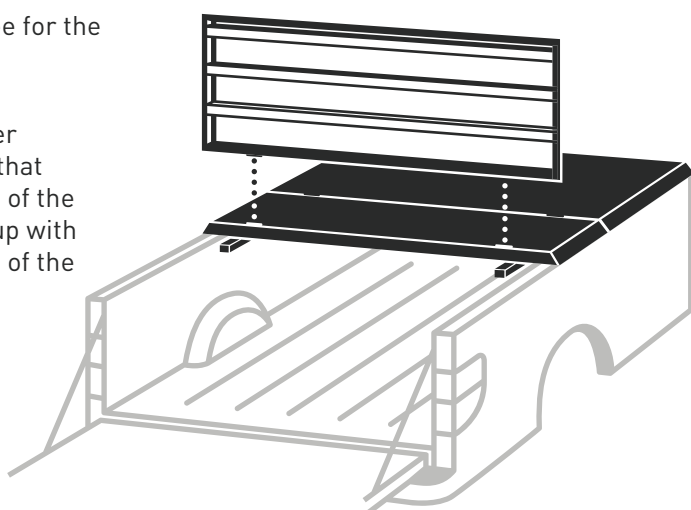

6 Center the DiamondBack cover side to side on the truck.

7 Tighten the cap clamps with a 9/16" socket.

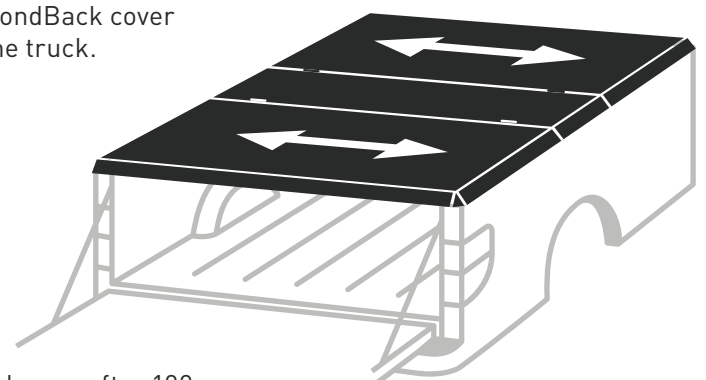

! Retighten your clamps after 100 miles. Check them every time you haul on top.

ADJUST THE LOCK RODS

Note: If your bed rail lips have sharp edges, they might tear the rubber caps on the end of the lock rods. To protect the end caps, peel the red adhesive backing from the bed rail edge trim pieces and place them on the bed rail lips.

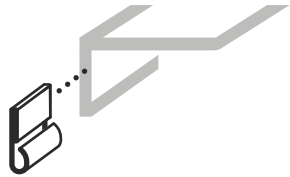

Note: If you have a plastic bed liner or bed rail caps that extend beyond the bed rail lip, trim the plastic so the lock rods can touch the bed rail lip.

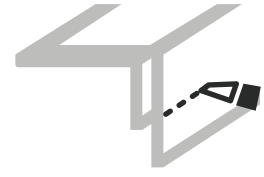

8 Loosen the set screws on the tailgate panel lock rod linkages.

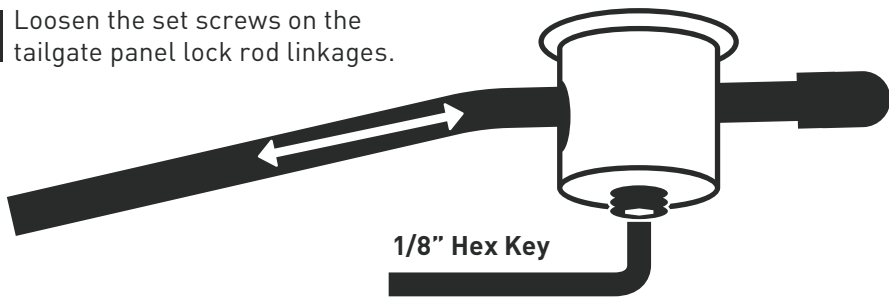

9 Adjust the length of the lock rods and retighten the set screws so that:

A. With the lock handle in the closed position, they travel as close as possible to—but no more than—1/2" past the bed rail lips.

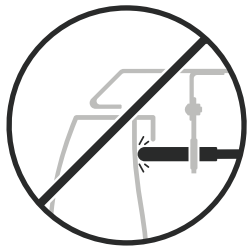
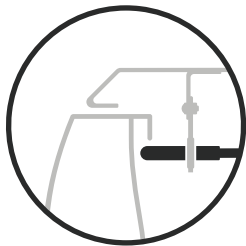

! To avoid lock handle damage, don't let the ends of your lock rods touch the bed wall.

B. The ends of the lock rods point toward the bed floor.

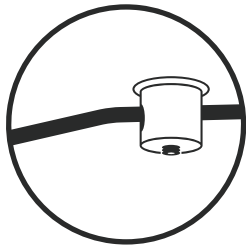

10 Position the lock rods tight against the underside of the bed rail lips so that they'll draw the panels down and compress the weatherstrip. Tighten the rod guide brackets with a 7/16" socket.

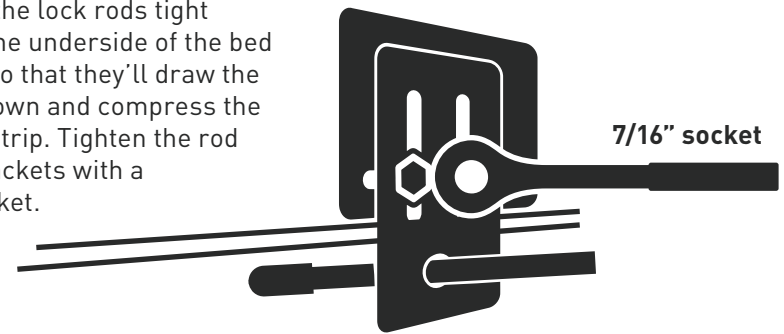

! To get the weatherstrip compression necessary for its adhesive to cure and the cover to keep out the weather, have a second person press down on the cover while you're adjusting the lock rods.

★ Using the access panels is easiest when you press down as you open or close them.



11 Repeat steps 1 through 3 for the cab panel.

! To ensure the best weatherstrip adhesion, leave your cover and tailgate closed and locked for 24 hours after you've made your final adjustments.

★ Your panels should be very difficult to operate at first. Leave them closed as much as possible for 3-4 days to break in the weatherstrip. After that period, you should find that the panels open and close without difficulty.

ATTACH THE SAFETY CATCH & GAS SPRINGS

12 Fit the **safety catch** around the ball studs on the driver side of the cab panel.

! To ensure the safety catch works properly, attach it as shown with the slotted half up and triangle pointing toward the cab.

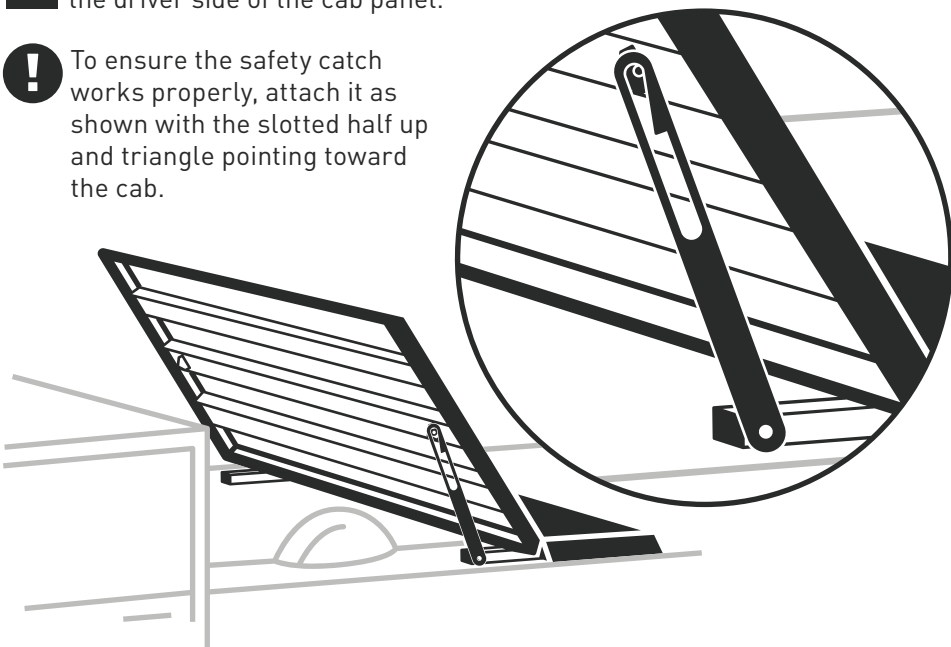

13 Attach a **gas spring** to the same ball studs.

! To avoid premature failure of your gas springs, attach them barrel up, shaft down.

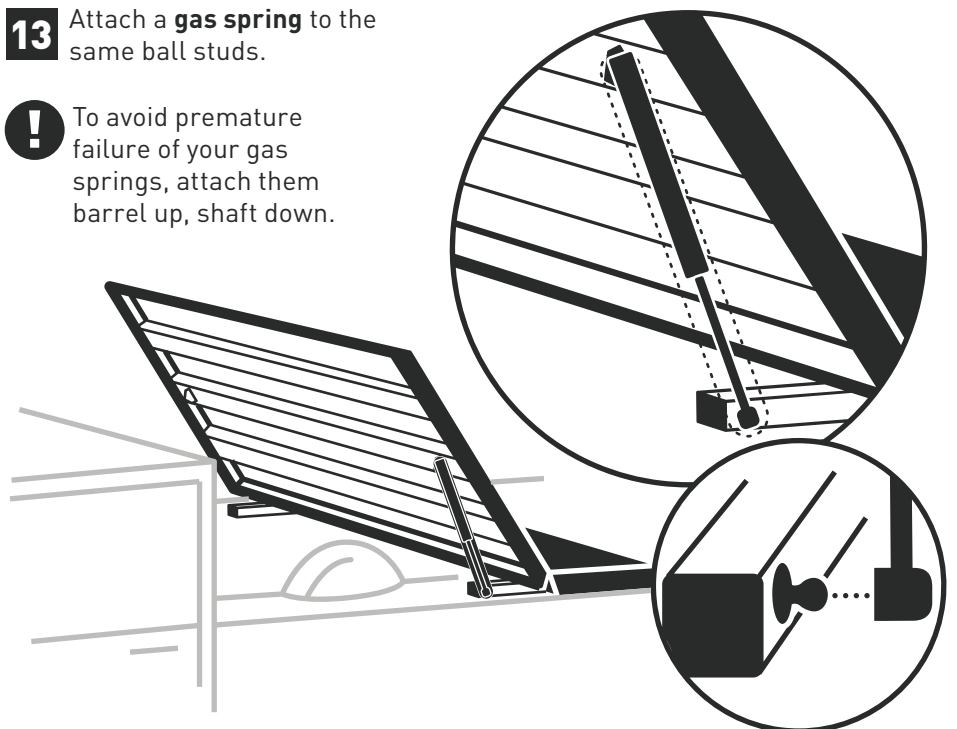

14 Attach the three remaining gas springs (barrel up, shaft down).

15 Leave the cover closed and locked for 24 hours to allow the weatherstrip adhesive, which is pressure-sensitive, to fully cure.

