

# INSTALLATION GUIDE

**60 minutes**  
Normal Install Time

**Keep an eye out for these icons:**

**IMPORTANT!**  
Important installation information

**Helpful Hints**  
Tips to assist installation

## PARTS INCLUDED:

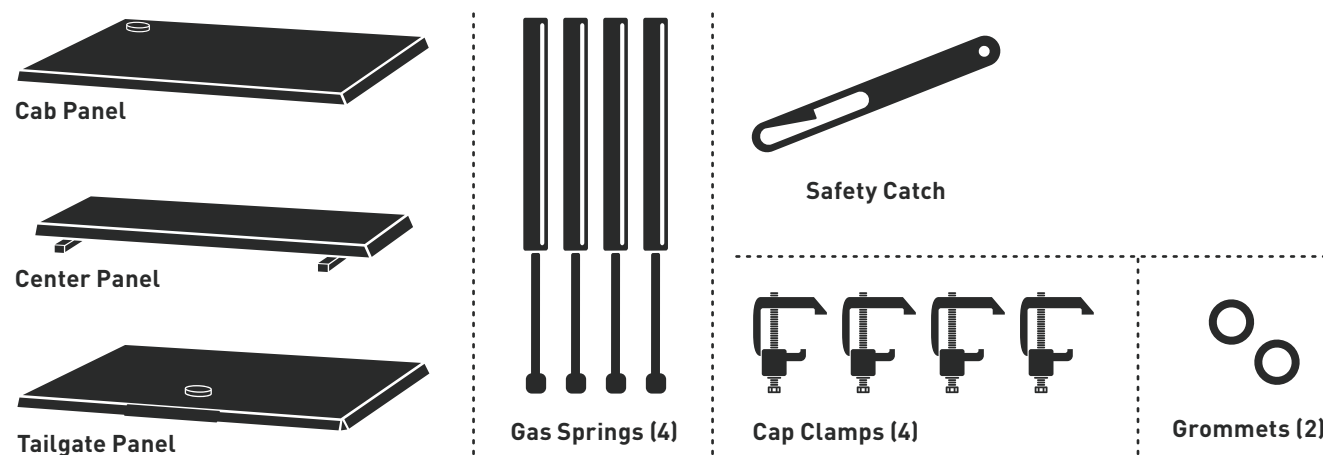

## PRE-INSTALLATION NOTES:

1. Install the **Bulkhead Prep Kit** before installing your DiamondBack cover. Refer to the **Bulkhead Prep Kit Installation Guide** for details.
2. If you are installing a **Low-Profile Cab Guard** or **HD Cab Guard**, you should mount it prior to installing your DiamondBack. Refer to the **Cab Guard Installation Guide** for details.
3. If you are installing a **Side-Loading ATV Carrier** on cargo bed longer than 6 feet, you must mount the **center panel adapter bars** prior to installing your DiamondBack HD. Refer to the **Side Adapter Bars Installation Guide** for details.
4. It's possible for one person to install a DiamondBack solo, but the whole process, especially positioning the panels and adjusting the lock rods, is much easier with two people.

## TOOLS REQUIRED:

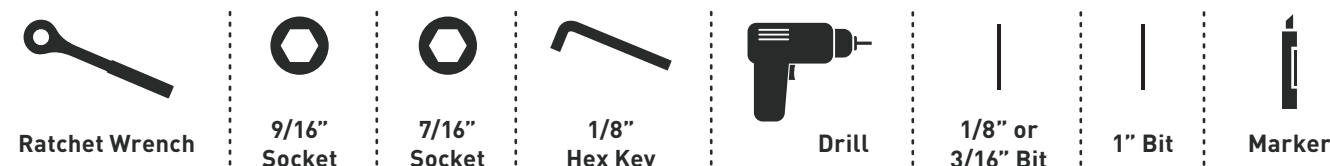

## POSITION THE PANELS

**1** Place the **center panel** across the center of bed, cheated slightly toward the tailgate.

Make the sure the arrow sticker on the underside of the center panel is pointing toward the tailgate.

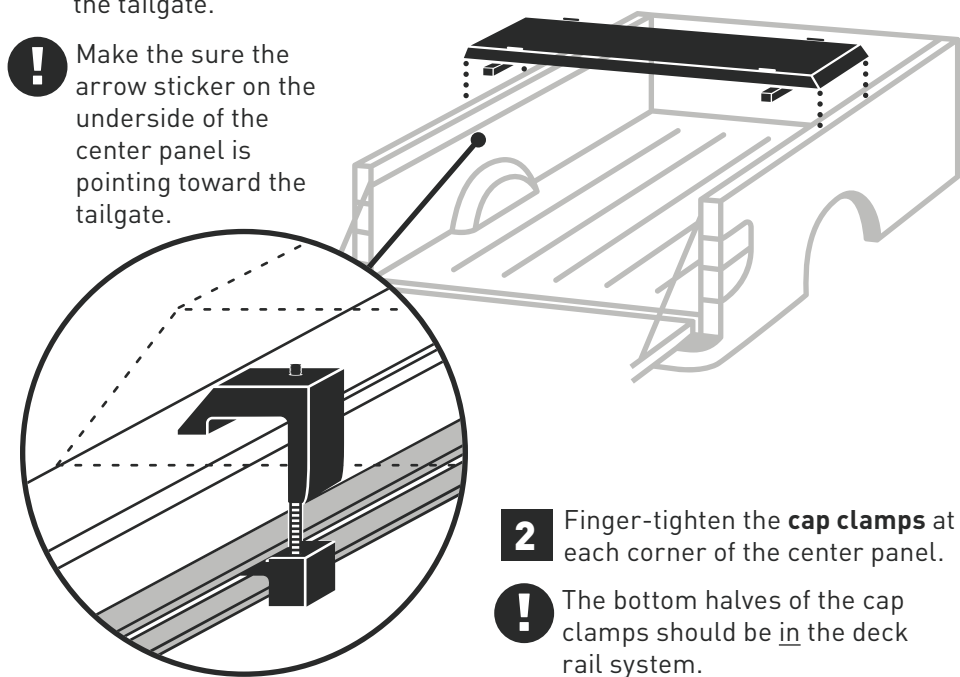

**2** Finger-tighten the **cap clamps** at each corner of the center panel.

The bottom halves of the cap clamps should be in the deck rail system.

**3** Slide the **cab panel** onto the center panel by mating their hinges. Close the cab panel slowly. Make sure it doesn't hit your cab.

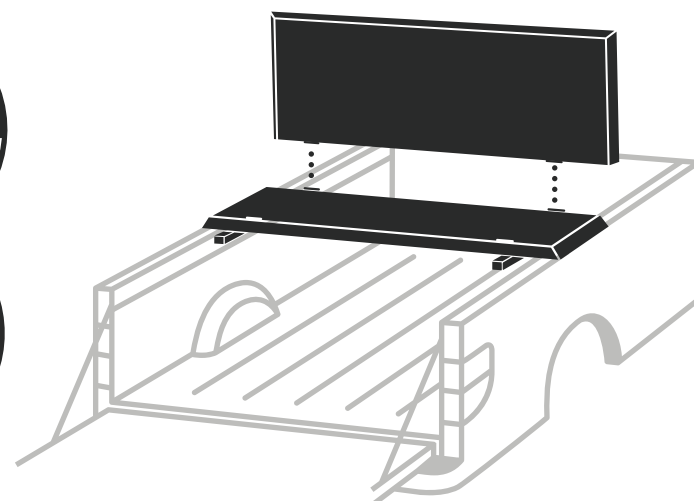
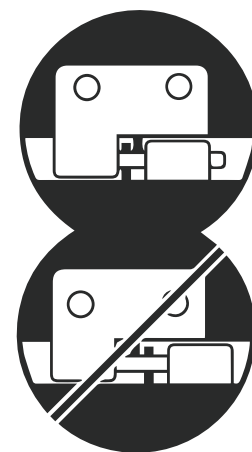

To avoid hinge damage, do not close the panel until hinges are fully mated: Tilt the panel past 90° and push to the left until the hinge lock tabs interlock.

Mating hinges is easiest when you line up the longer, left hinge pin first.

**4** Repeat step three for the **tailgate panel**.

**5** Position the cover front to back so that the leading edge of the cab panel lines up with the leading edge of the bulkhead.

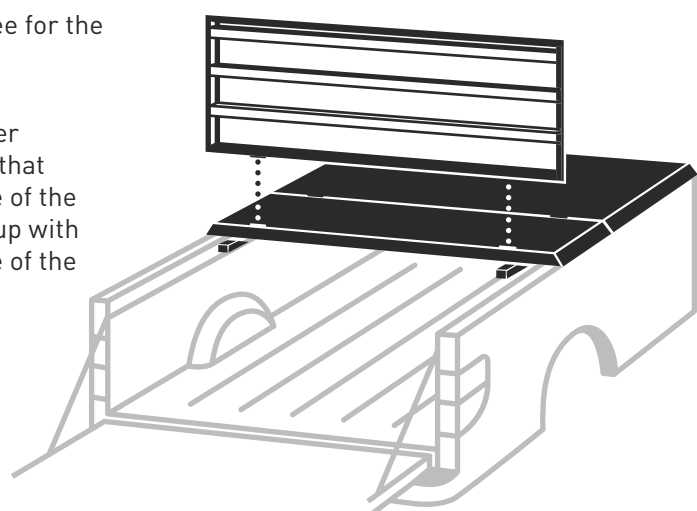

**6** Center the DiamondBack cover side to side on the truck.

**7** Tighten the cap clamps with a 9/16" socket.

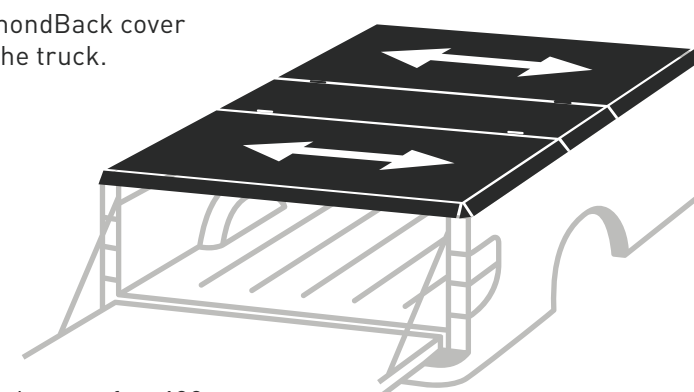

Retighten your clamps after 100 miles. Check them every time you haul on top.

# ADJUST THE LOCK RODS

## ADJUST THE CAB-PANEL LOCK RODS:

**8** Loosen the set screws on the cab-panel lock rod linkages.

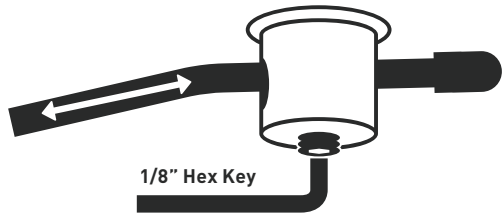

**9** Adjust the length of the lock rods and retighten the set screws so that:

A. With the lock handle in the closed position, the rods travel as close as possible to—but no more than  $1\frac{1}{2}$ " past the underside of the deck rail system.



B. The ends of the lock rods point toward the bed floor.

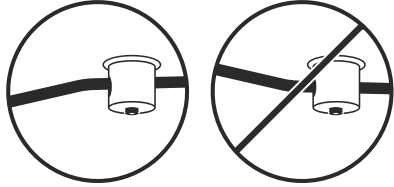

**!** To avoid lock handle damage, don't let the ends of your locking rods touch the bed wall.

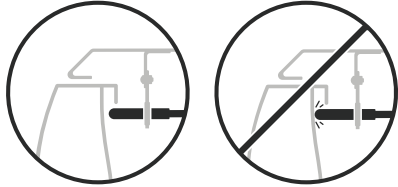

**10** Position the lock rods tight against the underside of the deck rail system so that they'll draw the panels down and compress the weatherstrip. Tighten the rod guide brackets with a  $\frac{7}{16}$ " socket.

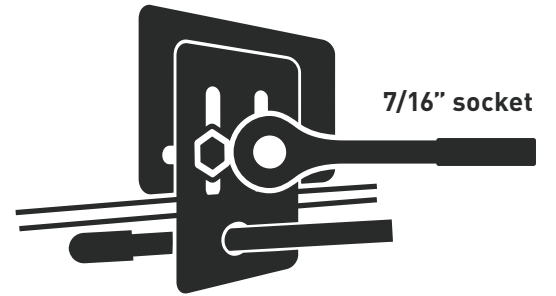

**!** To get the weatherstrip compression necessary for its adhesive to cure and the cover to keep out the weather, have a second person press down on the cover while you're adjusting the lock rods.

**★** Using the access panels is easiest when you press down as you open or close them.



## ADJUST THE TAILGATE-PANEL LOCK RODS:

**11** Have a second person press down on a rear corner of the cover. Under the same corner, hold the rod guide bracket so that its bolts are at the midpoint of its vertical slots. Mark the points on the bed wall where the lock rods will hit.

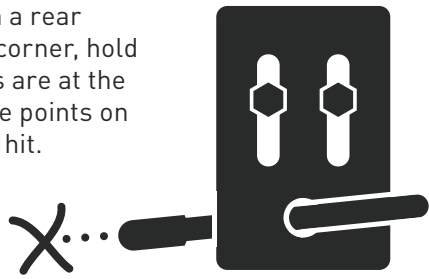

**12** Repeat at the opposite corner.

**13** Open the tailgate panel. Drill the marks with a  $\frac{1}{8}$ " or  $\frac{3}{16}$ " bit.

**14** Drill the marks again with a 1" bit. Insert a grommet into each hole.

**15** Close the tailgate panel. Repeat steps 8 through 10 for the tailgate panel using the new holes instead of the deck rail system.

**!** To ensure the best weatherstrip adhesion, leave your cover and tailgate closed and locked for 24 hours after you've made your final adjustments.

**★** Your panels should be very difficult to operate at first. Leave them closed as much as possible for 3–4 days to break in the weatherstrip. After that period, you should find that the panels open and close without difficulty.

# ATTACH THE SAFETY CATCH & GAS SPRINGS

**16** Fit the **safety catch** around the ball studs on the driver side of the cab panel.

**!** To ensure the safety catch works properly, attach it as shown with the slotted half up and triangle pointing toward the cab.

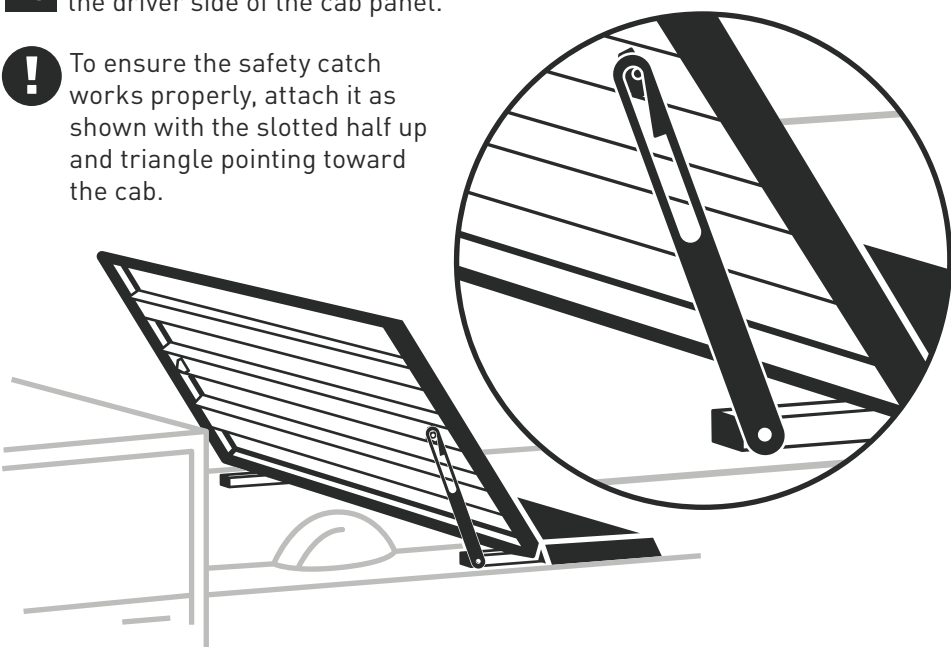

**17** Attach a **gas spring** to the same ball studs.

**!** To avoid premature failure of your gas springs, attach them barrel up, shaft down.

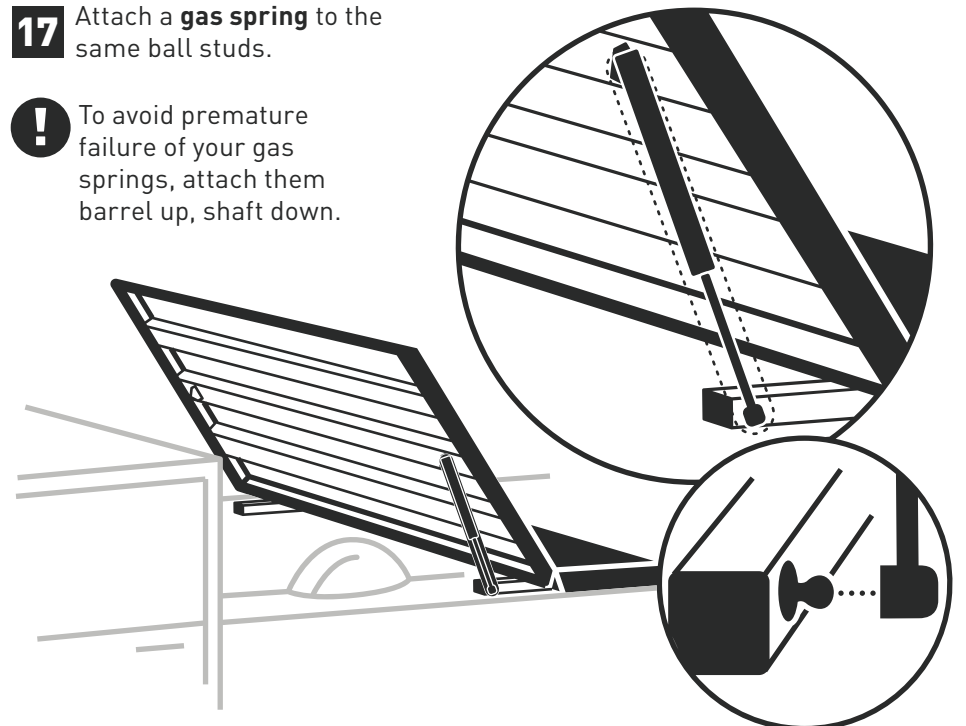

**18** Attach the three remaining gas springs (barrel up, shaft down).

**19** Leave the cover closed and locked for 24 hours to allow the weatherstrip adhesive, which is pressure-sensitive, to fully cure.

