



# Fender Eliminator Kit

APPLICATION

YEAR	MODEL
2011-2013	Yamaha FZ8
PRODUCT	
070BG138001	Fender Eliminator Kit

 This product is not DOT approved. Yoshimura R&D of America, Inc. is not liable or responsible for any resulting event caused by the installation of this product. Check with local laws and regulations for compliance prior to installation and use. This product is not intended for use on public highways.

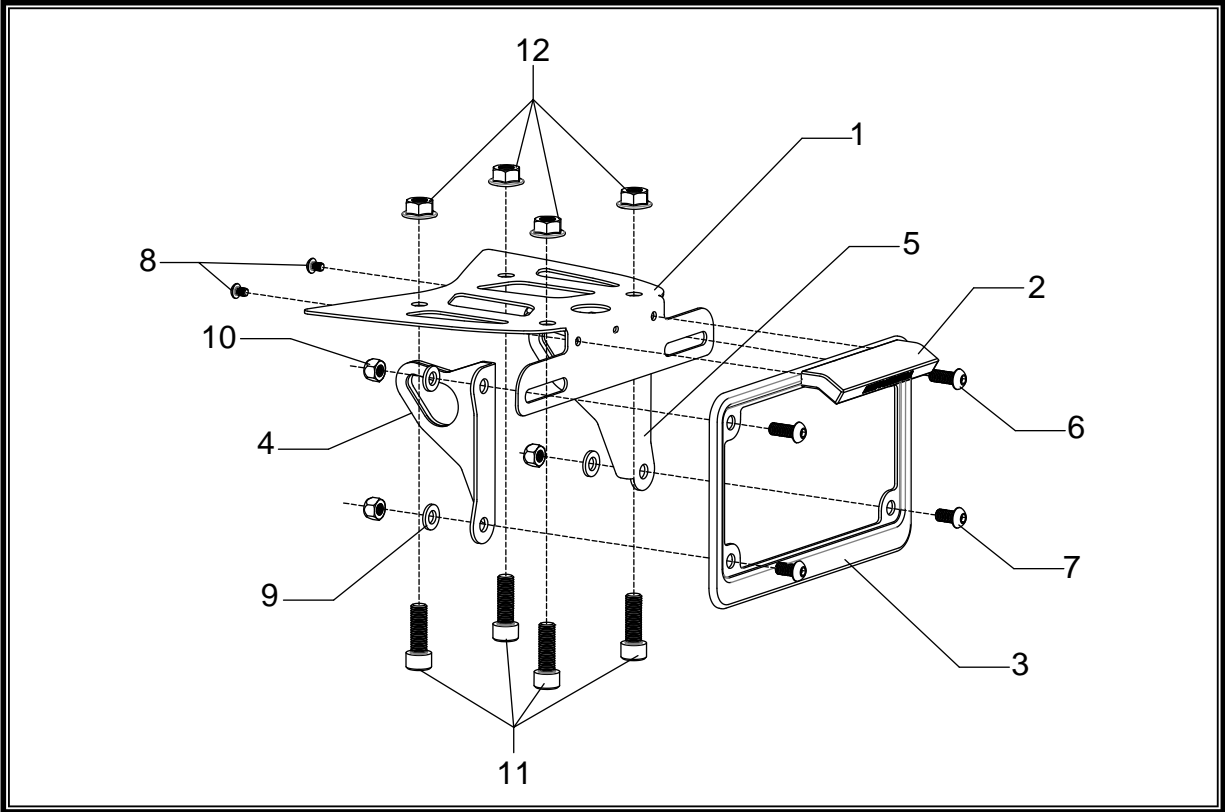

No.	Part #	Description	Qty
1	13800-FEBKT	Yoshimura Fender Eliminator Bracket	1
2	070BG-LH-K	Yoshimura LED License Plate Light	1
3	070BG-LPF	Yoshimura Aluminum License Plate Frame	1
4	13630-TSBL-00	Left Turn Signal Bracket	1
5	13630-TSBR-00	Right Turn Signal Bracket	1
6	M6X16BHS	6mm x 16mm Button Head Screw	2
7	M6X12BHS	6mm x 12mm Button Head Screw	2
8	M4X6BHS	4mm x 6mm Button Head Screw	2
9	6MMWASHER	6mm Washer	4
10	6MMLN	6mm Lock Nut	4
11	M8X25	8mm x 25mm Socket Head Cap Screw	4
	8MMNUT	8mm Flange Nut	4
**	ZT-200	Zip Ties	3
**	94785-01-ND	Butt Connectors	2
**	17029	Yoshimura Sticker Sheet	1

**-TOOLS REQUIRED-**

*Metric Socket Set • Combination Wrench Set • Metric Allen Wrench Set*

**-REMOVAL-**

1. **Remove rear seat.**
2. **Remove 4 bolts securing the stock fender assembly in place.**
3. **Lower stock fender assembly and disconnect turn signals, brake light, and license plate light.**
4. **Remove stock turn signals from fender assembly as they will be used with the Yoshimura Fender Eliminator Kit.**

**-INSTALLATION-**

1. **Install (070BG-LH-K) LED License Plate Light onto (13800-FEBKT) Fender Eliminator Bracket using the two (M4X6BHS) screws provided in the kit.**
2. **Install (13800-FEBKT) Fender Eliminator Bracket using the four (M8X25) bolt and (8MMNUT) nut provided in the kit. See diagram for proper orientation and order of hardware.**
3. **Install stock turn signals onto (13630-TSBL-00 / 13630-TSBR-00) left and right turn signal brackets. Secure turn signal brackets to fender eliminator bracket. See diagram for proper orientation and order of hardware.**
4. **Cut off and remove 2" of the sleeve at the middle of the harness where the wires split off to each of the turn signals and to the rear license plate illumination light. Cut off the stock license plate illumination light wires 75mm away from the light.**
5. **Route license plate light and turn signal harness through stock opening in undertail cowling.**
6. **Using the supplied (94785-01-ND) butt connectors, connect the license plate illumination light wires to the plate light as follows:**

**Yoshimura FE Wire-----Stock Sub-harness**  
**Red Wire-----Blue**  
**Black Wire-----Black**

**(Note: Use of soldering and heat shrink tubing is recommended)**

7. **Re-connect turn signal wires.**
8. **To prevent loose wires and/or connections, route and secure the wires inside the tail section using the provided zip ties from the kit.**
9. **Re-install rear seat.**
10. **Check for proper function of license plate light and turn signals and that all brackets and components are secure prior to riding.**