









Installation Instructions WrapAround™ Windjammer™

Vehicle Application

- Jeep Wrangler
2003 - 2006
Part Number: 80035

www.Bestop.com - We're here to help! Visit our web site and click on ["Ask a Question"](#). Click here for more [Jeep Accessories by Bestop](#).

INSTALLATION TIME	SKILL LEVEL
	<div style="display: flex; justify-content: space-around;"> 1 2 3 4 </div>
1/2 Hour	1 - Easy

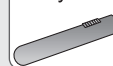
TOOLS				
 Safety Glasses	 Torx Wrench	 Power Drill	 Phillips Screwdriver	 Center Punch
T30		1/8" Bit		
 Pencil	 Utility Knife			

This product is designed to be used with factory door surrounds.

Installation Tips

Before you begin installing this assembly, read all instructions thoroughly.

For a smooth fit:

For ease in installation, the product should be installed at temperatures above 72° F. Below this temperature, the fabric may contract an inch or more, making it difficult to fit to the vehicle. It is normal for fabric to contract and wrinkle when stored in the shipping carton. Within a few days after the installation, the fabric will relax and the wrinkles will disappear.

	CAUTION	Safety glasses should be worn at all times while installing this product.
---	----------------	---

	WARNING	This product is designed primarily to enhance the appearance of the vehicle and to shield the occupants from ordinary weather conditions. Do not rely in any way on the components of this product to contain occupants within the vehicle, or to protect against injury or death in the event of an accident. This product will not protect the occupants from falling objects. Never operate the vehicle in excess of manufacturer's specifications.
---	----------------	--

WEAR SEAT BELTS AT ALL TIMES

Read and follow, precisely, all installation instructions provided when installing product. Failure to do so may result in a poor fit and could place occupants of the vehicle in a potentially dangerous situation.

WrapAround™ Windjammer™ – Installation Instructions

Parts List and Hardware Identification

Windjammer™ Qty - 1
 "Z" Channel, Part Number 304.64 Qty - 1

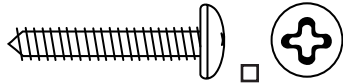

#8 x 1" Pan Head Screw Part Number 295.95, Qty - 5,

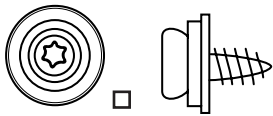

Snap Head Screw, Part Number 200.49, Qty - 3,

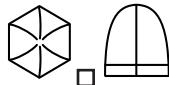

Acorn Locknut, Part Number 427.11, Qty - 3,

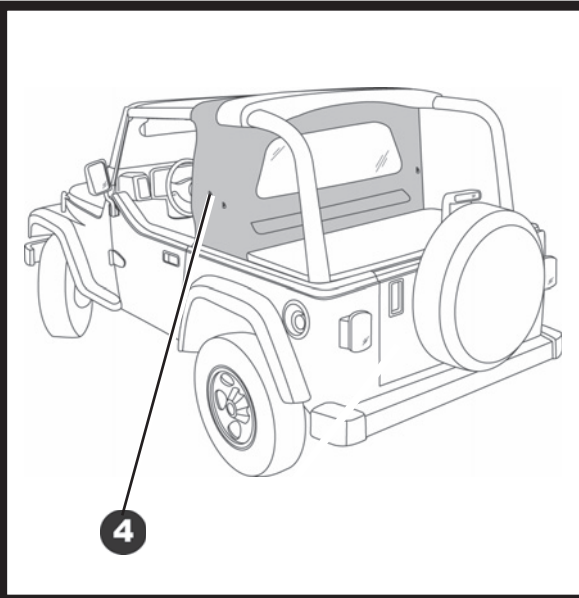

3 Wrap Fabric around Bows

Wrap the top fabric tightly around the bows. Then wrap the legs tightly around the top fabric.

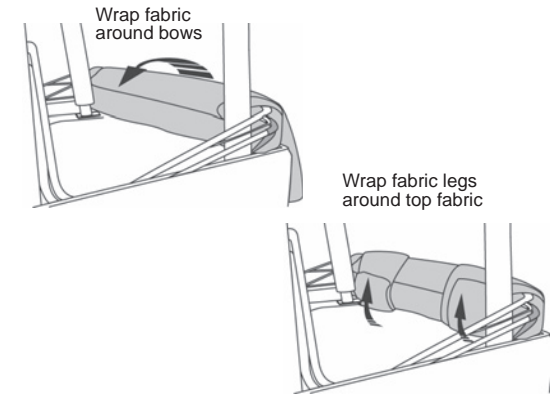

1 Remove Side and Rear Windows

Open the zippers on the Right and Left Side Windows. Remove the windows and store safely (We recommend storing them in Bestop's Window Storage Duffel, 42810.).

Open the zipper on Rear Window. Pull the Tailgate Bar out of the mounts on the vehicle. Slide the Tailgate Bar off the Rear Window and set it aside to be used later.

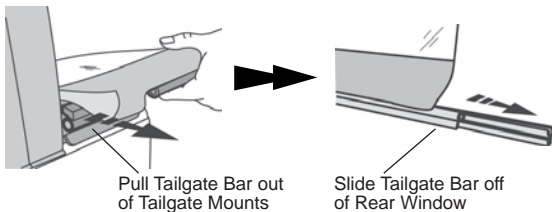

2 Fold the Top Down

Release the front of the top from the windshield and lay the bows down. Refer to owner's manual for instructions.

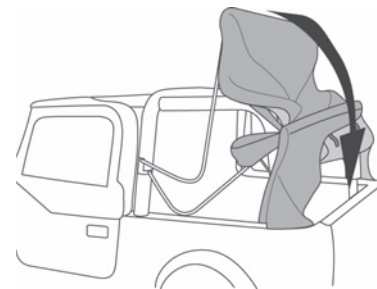

4 Remove Top and Hardware Assemblies

Use a T30 Torx to remove the soft top assembly and the hardware.

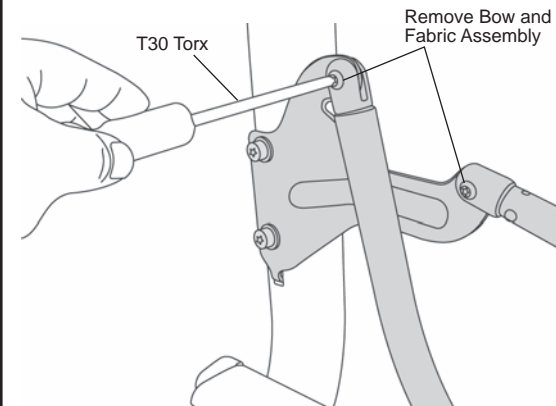

WrapAround™ Windjammer™ – Installation Instructions

5 Cut Slits for Pivot Brackets

Locate the reinforced plastic area on each side of the center glass on the WrapAround™ Windjammer™. Use a utility knife to cut a vertical slit through the center of the reinforcement.

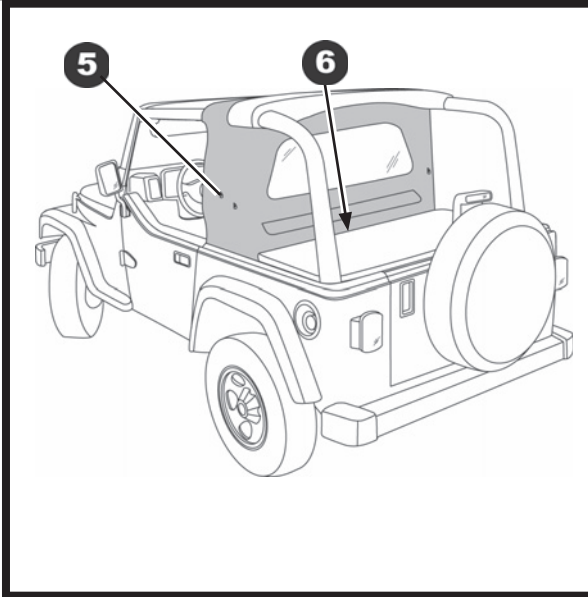
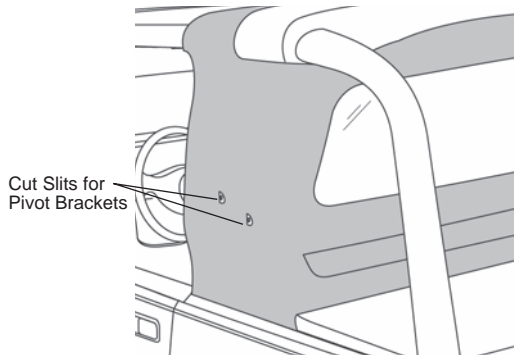

WARNING

Check for wiring and fuel lines before drilling holes in riser.

6 Install "Z" Channel

Fold the front seats forward and locate the "Z" Channel in the parts kit. Orient the channel so that, when installed, the opening will be down. Place the channel on the vertical face of the riser between the front and rear floors, centered in the flat area in the middle of the vehicle. The top edge of the channel should be flush with the top of the riser. Use the holes in the channel as guides to mark, center punch and drill five 1/8" holes. Install the channel using the five #8 x 1" Pan Head Screws from the parts kit.

NOTE It is easier to drill holes by either slitting the carpet with a 1/2" "X" shape to access the sheet metal, or center punch through the carpet, remove the carpet and drill the necessary holes - then add smaller slits in the carpet to access the holes for attachment.

After drilling the holes for the "Z" Channel in the floor riser, put silicone sealer on the holes before installing the channel with the screws.

If the vehicle is equipped with a factory console, it will be necessary to leave the center screw out of the channel.

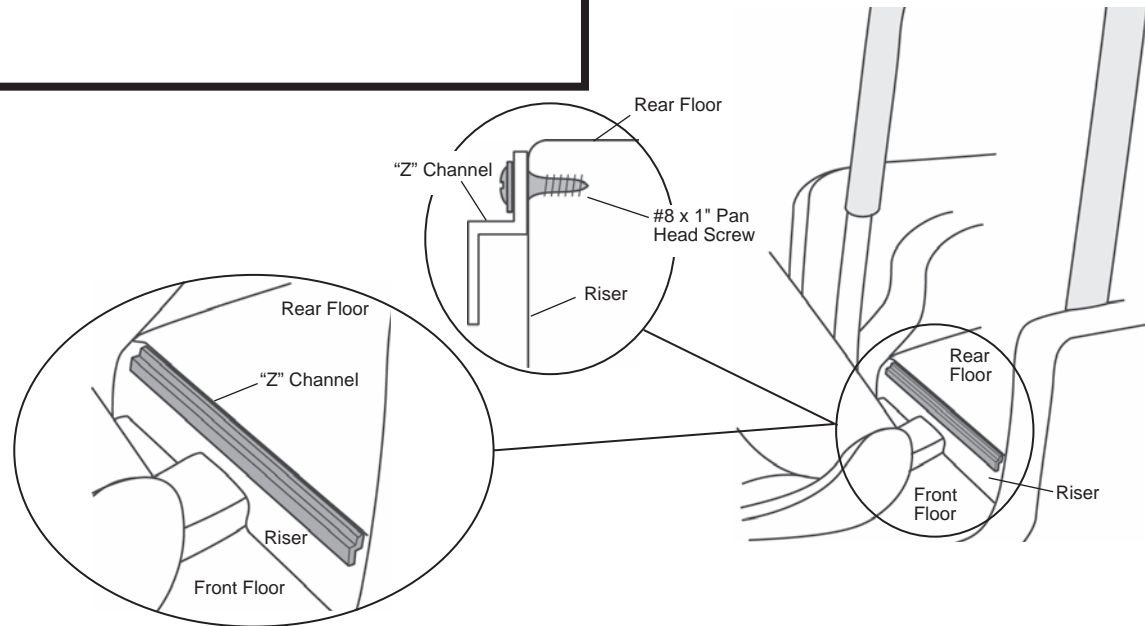

WrapAround™ Windjammer™ – Installation Instructions

7 Secure WrapAround™ Windjammer™ to Door Surround

Loosen the knobs that secure the Door Surround to the vehicle to allow the surround to lean toward the rear of the vehicle.

Roll the plastic strip along the edge of the Wrap-Around™ Windjammer™ into the channel in the Door Surround on each side of the vehicle.

Place the Door Surround back into position and tighten the knobs.

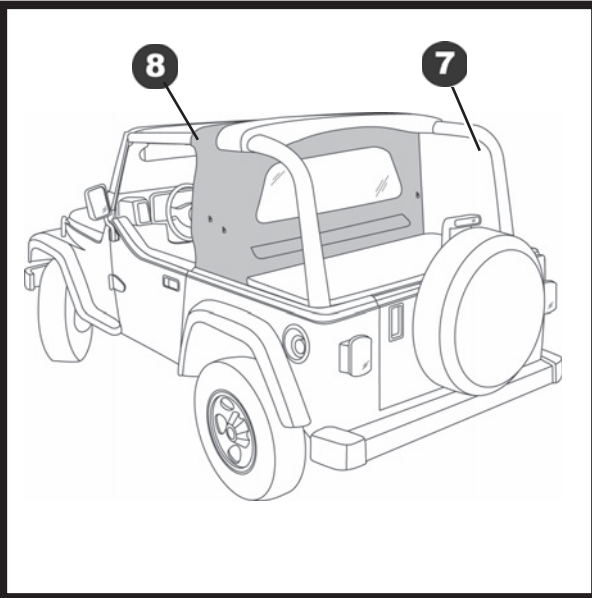
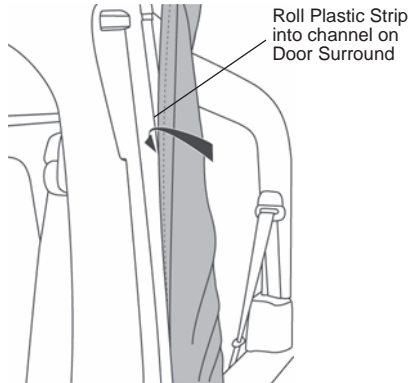

8 Fasten Straps

Orient the Windjammer with the window toward the top and with the vinyl side out, toward the rear of the vehicle. Start with the top straps and wrap the four top straps around the sport bar, between the sport bar and the Sound Bar, if one is present. Then thread the end of each strap through each buckle. Loosely tighten each strap to hold the Screen in position.

NOTE If the vehicle is equipped with a Soundbar, the upper straps must be inserted between the Soundbar and Pad.

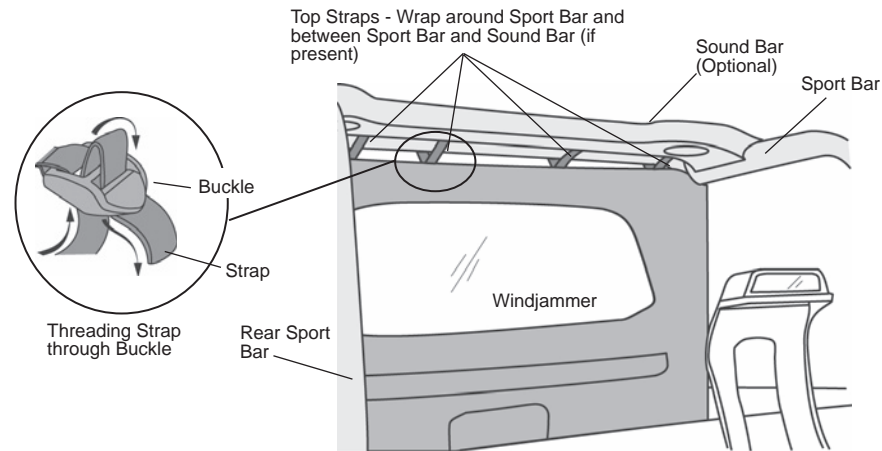

WrapAround™ Windjammer™ – Installation Instructions

9 Secure Windjammer to “Z” Channel

Gently pull down on the bottom of the Windjammer fabric and slip the plastic strip sewn on the bottom of the fabric into the “Z” Channel installed earlier.

Once the plastic strip is in place in the “Z” Channel, fasten the web straps on the door to the loop strips on either side of the opening. Adjust the plastic strip if necessary. Tighten up all the straps including the hook and loop.

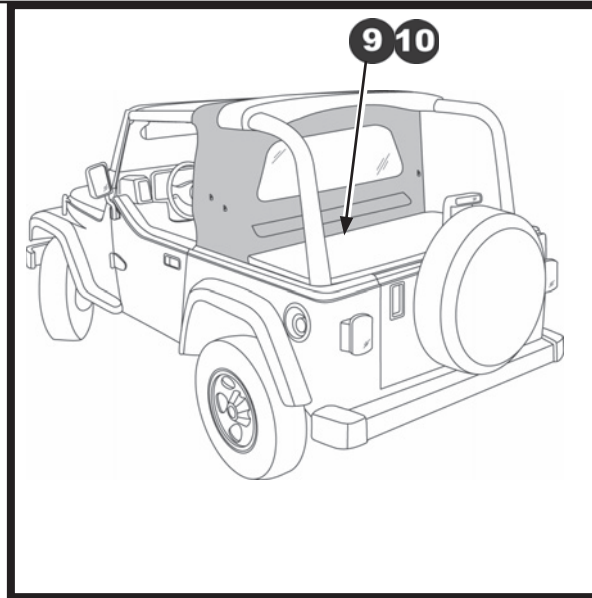
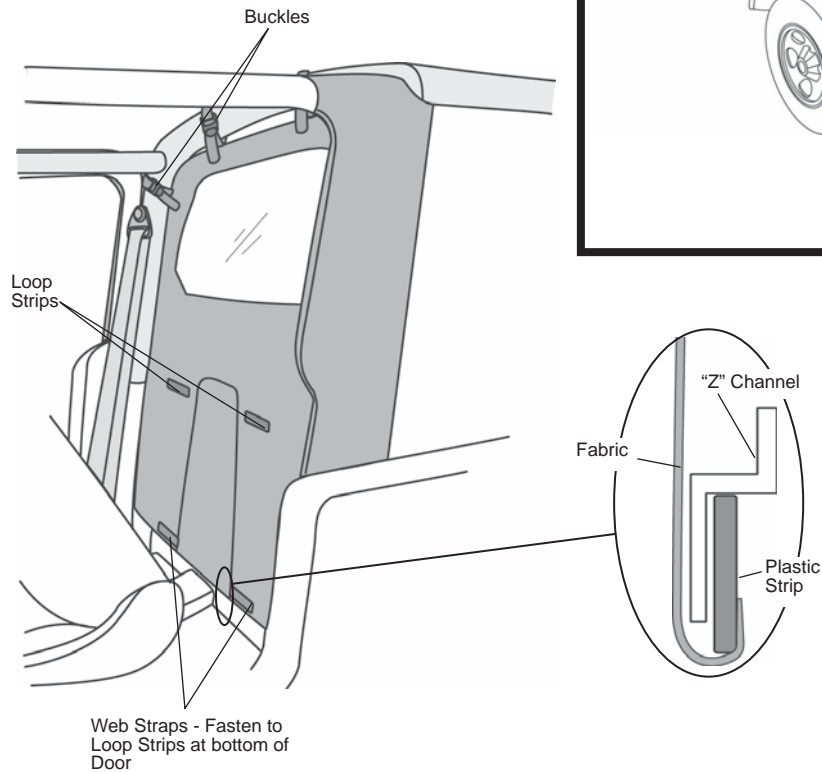

10 To Open the Center Flap

To open the center flap in the Windjammer, pull on the Web Straps at the bottom of the door to release them from the Loop Strips. Roll the door and fasten the Web Straps to the Loop Strips on each side of the top of the door.

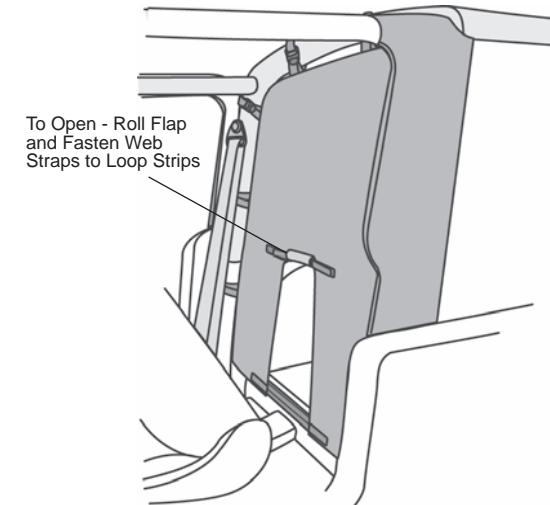

WrapAround™ Windjammer™ – Installation Instructions

Care and Maintenance of your Bestop Product

Your Bestop product is made of the finest materials available. To keep it looking new and for the maximum possible wear, it will need periodic cleaning and maintenance.

Washing: The fabric should be washed often using soap, warm water and a soft bristle brush. Rinse with clear water to remove all traces of soap or use Bestop-recommended Bestop Cleaner and Bestop Protectant. Bestop Cleaner and Bestop Protectant are specially formulated to provide a total cleaning and protection system. Bestop Cleaner will not harm vehicle finish, is biodegradable and environmentally friendly. Bestop Protectant protects against UV-fading, cracking and hardening.

Windows: Keep windows clean to avoid scratching. DO NOT use a brush on the windows! Wash with a water-soaked cloth or sponge and a mild dishwashing detergent or use Bestop-recommended Bestop Vinyl Window Cleaner, which safely cleans and protects vinyl windows while helping prevent UV damage. NEVER WIPE THE WINDOWS WHEN THEY ARE DRY. Be careful when cleaning snow or frost from the vinyl windows since they are easily scratched and may crack at low temperatures. DO NOT roll the sides or rear window in cold weather. The windows become stiff and will crack.

Water: Seeping through at the seams may be stopped by applying 3-M Scotchgard® on the inside of the seams. Rips in the fabric may be repaired with Bondex® iron on patches. Iron the patches to the Inside of the top, carefully following the Bondex® instructions.

LIMITED WARRANTY

We warrant our product to be free from defects in material and workmanship, for the terms specified below, provided there has been normal use and proper maintenance. This warranty applies to the original purchaser only. All remedies under this warranty are limited to the repair or replacement of any item or items found by the factory to be defective within the time period specified. If you have a warranty claim, first you must call our factory at the number below for instructions. You must retain proof of purchase and submit a copy with any items returned for warranty work. Upon completion of warranty work, if any, we will return the repaired or replaced item or items to you freight prepaid. Damage to our products caused by accidents, fire, vandalism, negligence, misinstallation, misuse, Acts of God, or by defective parts not manufactured by us, is not covered under this warranty.

THE WARRANTY TIME PERIOD IS AS FOLLOWS FOR REPLACE-A-TOP™, SAILCLOTH REPLACE-A-TOP™, SUPERTOP®, SUPERTOP® REPLACEMENT SKINS, SUNRIDER®, AND TIGERTOP®: TWO YEARS FROM DATE OF PURCHASE.

THE WARRANTY TIME PERIOD IS AS FOLLOWS FOR ALL OTHER “SOFT GOODS” MANUFACTURED BY OUR COMPANY (USING PRIMARILY VINYL, PLASTICS, AND/OR FOAM): ONE YEAR FROM DATE OF PURCHASE.

THE WARRANTY TIME PERIOD IS AS FOLLOWS FOR ALL OTHER “HARD GOODS” MANUFACTURED BY OUR COMPANY (USING PRIMARILY METALS, PLASTICS, AND/OR FIBERGLASS): ONE YEAR FROM DATE OF PURCHASE.

ANY IMPLIED WARRANTIES OF MERCHANTABILITY AND/OR FITNESS FOR A PARTICULAR PURPOSE CREATED HEREBY ARE LIMITED IN DURATION TO THE SAME DURATION AND SCOPE AS THE EXPRESS WRITTEN WARRANTY. OUR COMPANY SHALL NOT BE LIABLE FOR ANY INCIDENTAL OR CONSEQUENTIAL DAMAGE.

Some states do not allow limitations on how long an implied warranty lasts, or the exclusion or limitation of incidental or consequential damages, so the above limitations or exclusions may not apply to you. This warranty gives you specific legal rights, and you may also have other rights which vary from state to state.



For further information or request for warranty work, please contact:

Bestop Inc., Customer Service
Toll-Free: (800)845-3567
Main: (303)465-1755
E-mail: csbestop@Bestop.com
Website: www.Bestop.com