

Ford SuperCrew Installation Instructions

- Read manual and these special instructions prior to installation.
- Refer to owner's manual to install your Ford SuperCrew TruXedo® kit.
- Follow this instruction sheet to install TruXedo® side rails on your Ford SuperCrew.
- Side rails are notched and pre-bent to conform to pickup bed.

NOTE: Images in this instruction contain rails from an Original TruXedo® cover or a Lo Profile® cover. Both kit's rails are installed in the same way. The difference between the two is shown in step 2.

STEP 1: Position side rail 1/8" higher than bed cap at front of pickup box. Attach two clamp assemblies at front of side rail in pickup box recess on side of pickup box.

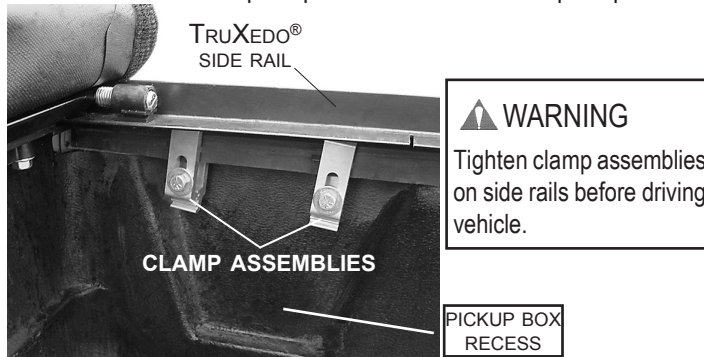

STEP 2: Install clamp assembly as shown with female clamp positioned against top of bed rail. Adjust male clamp as required to level side rail. Tighten clamp assembly.

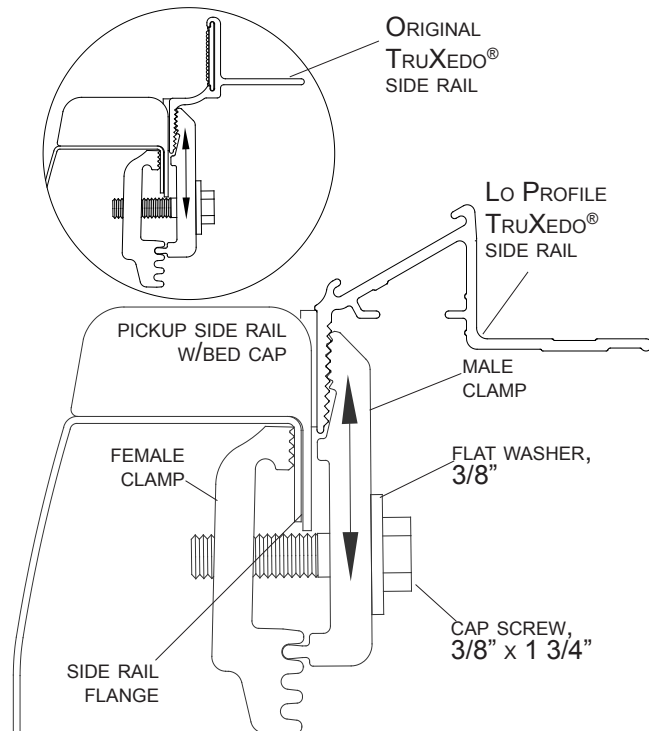

STEP 3: Attach two clamp assemblies at rear of side rail in recess of pickup box. Side rail is notched to fit on top of pickup box post.

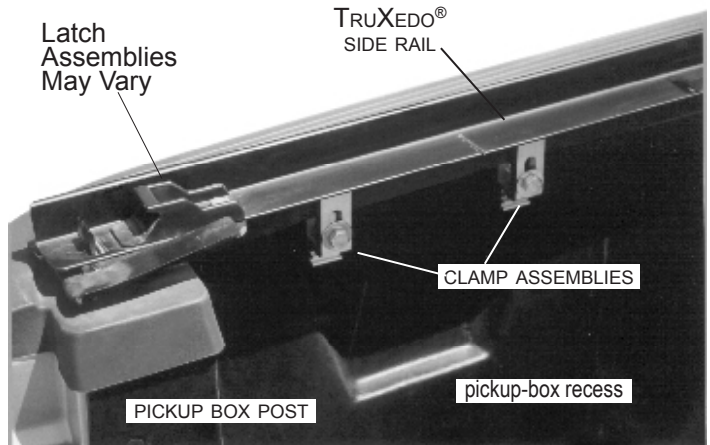

STEP 4: Mount side rail at tailgate end above bed cap as shown. Rear header seal functions best when tailgate is closed and cover is latched on top of tailgate.

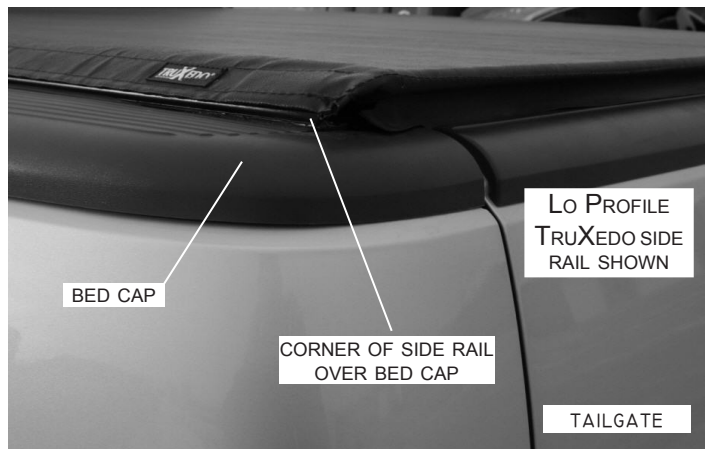

Clamp Assembly

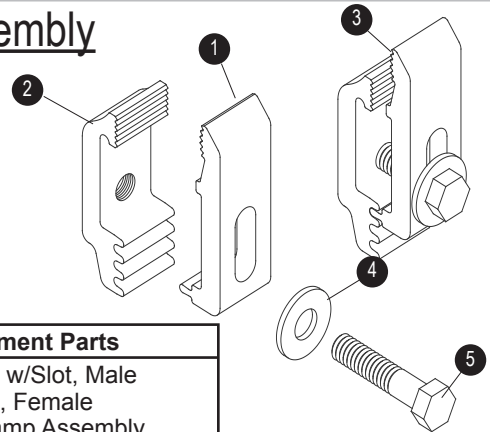

Replacement Parts

- 1 1703254 Clamp w/Slot, Male
- 2 1115184 Clamp, Female
- 3 1115191 Clamp Assembly
- 4 1700429 Flat Washer, 3/8"
- 5 1700369 Cap Screw, 3/8" x 1 3/4"

TruXedo, Inc.

P.O. Box 1078, 2209 Kellen Gross Dr., Yankton, South Dakota 57078 Call Toll Free: 1-877-TRUXEDO (1-877-878-9336)
Fax: (605) 664-9304 Visit Us Online: <http://www.truxedo.com>

TRUXEDO®
Yankton, SD 1-877-TRUXEDO

P/N 1114692 Rev. F