

Read installation instructions in its entirety before installing your Coil-Rite Kit

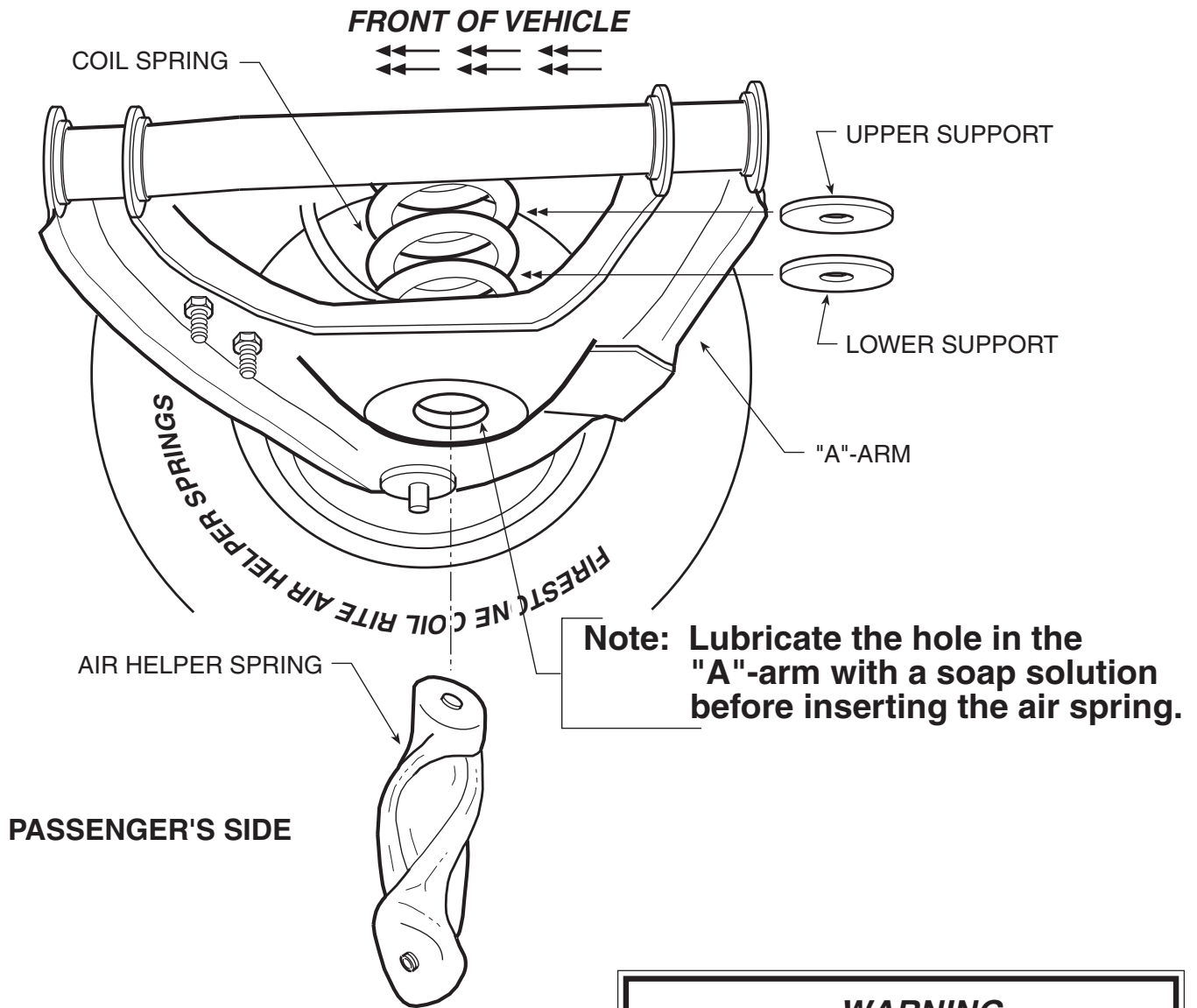

PARTSLIST

DESCRIPTION	QTY.
AIR SPRING	2
SUPPORTS	4
18' AIR LINE	1
NYLON TIE	6
CLIP	2
3/8" -16 x FLANGED LOCK NUT	2
PUSH-TO-CONNECT INFLATION VALVE	2
1/4" X 1/4" ELBOW UNION	2
5/16" FLAT WASHER	4
THERMAL SLEEVE	2

WARNING

Do not inflate this assembly when it is unrestricted. The assembly must be restricted by a coil spring. Do not inflate beyond recommended operating pressures for your specific vehicle. Improper use or over inflation may cause property damage or severe personal injury.

*FIRESTONE INDUSTRIAL PRODUCTS
CARMEL, INDIANA, USA*

RECOMMENDED OPERATING PRESSURES

1/2 TON VEHICLES	4 - 45 psi
3/4 TON VEHICLES	10 - 60 psi
GM P-30 10,000 lb. - 15,000 lb. GVWR	40 - 70 psi
GM P-30 16,000 lb. GVWR and up	60 - 90 psi

COIL-RITE INSTALLATION PROCEDURE

STEP 1 - PREPARE THE VEHICLE

With the vehicle on a solid level surface, chock the rear wheels. Disconnect the negative battery cable. Raise the front wheels of the vehicle using a lift or platform jack rated for your vehicle's weight. Lower the vehicle frame onto jack stands rated for your vehicle's weight, allowing the suspension to hang freely. (DO NOT use wood or concrete blocks to support the weight of the vehicle.)

STEP 2 - REMOVE THE EXISTING AIR SPRING

If the vehicle is not equipped with air springs, proceed to Step 3.

Exhaust the air from the air springs completely. Using an electric drill and a 1-1/2" hole saw *without a guide bit*, remove the center portion of the air spring in the hole in the lower A-arm. Lubricate the hole in the lower A-arm with a soap and water solution so that the air spring can easily be pulled through the hole. Pull the air spring through the hole in the A-arm with a pair of vise grips *see Figure "B"*. Remove the existing support located at the top of the coil spring.

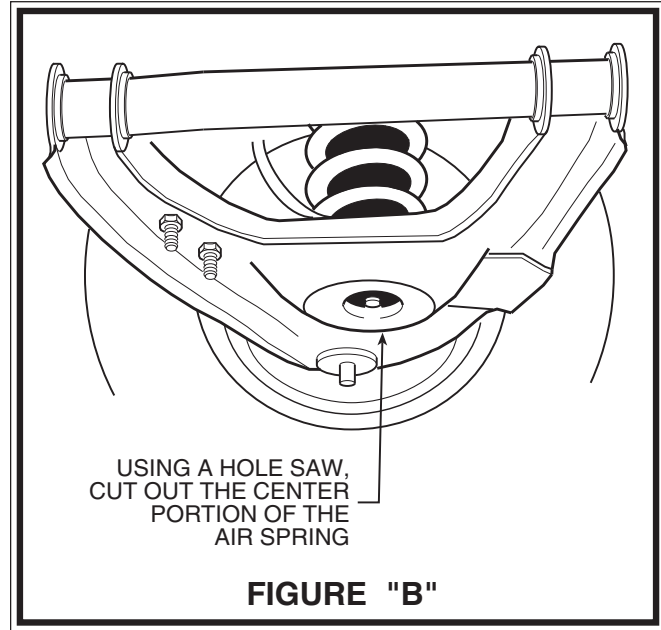

STEP 3 - PREPARE THE AIR SPRING

Cut a section of air line tubing 3 inches long and insert it into the push-to-connect fitting on the air spring. Exhaust the air from the air spring by rolling it up tightly in a twisting motion. After the air has been exhausted, install the plug into the tubing coming out of the air spring. *See Figure "A"*.

STEP 4 - INSTALL THE AIR SPRING

Insert the air spring into the hole in the lower A-arm so that the air inlet is oriented towards the ground *see Figure "A"*. With the air spring still rolled tightly, work it through the hole in the lower A-arm. Rotate the air spring while pushing it through the hole in the A-arm. Push the air spring completely through the hole. Allow the air spring to expand to its normal shape once inside the coil spring, *see Figure "B"*.

Using a blunt tire iron or socket extension, reach through the top of the coil spring and push the air spring downward. Insert the upper support through the coil spring. Place the upper support so that the stud in the upper spring seat inserts into the hole in the upper support, *see Figure "A"*.

Install the lower support in the same manner between the bottom of the air spring and the lower spring seat, *see Figure "A"*.

Remove the plug from the air line and install the elbow union onto the section of air line, *See Figure "D"*.

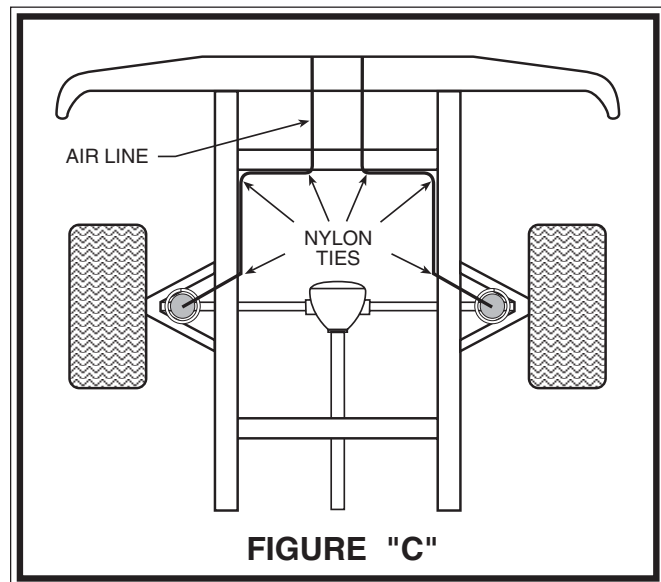

COIL-RITE INSTALLATION PROCEDURE

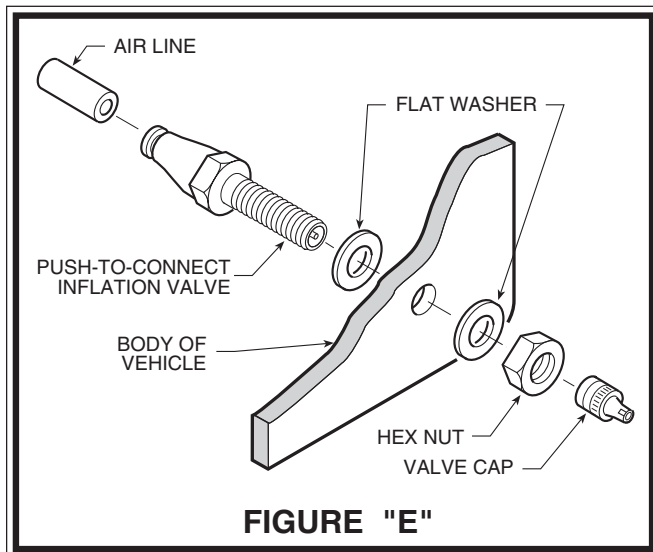
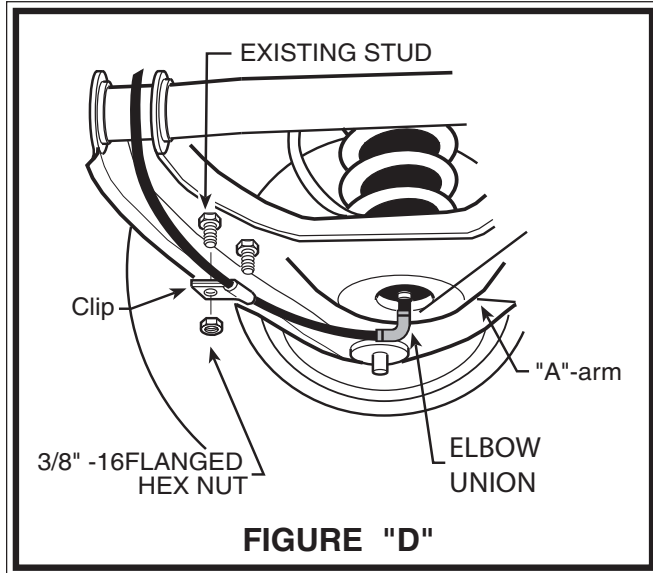

STEP 5 - ROUTE THE AIR LINE

Cut the air line tubing into two equal lengths, making sure the end is cut squarely (a "saw" cut with a sharp knife is preferred). Route the air line from the elbow union to the desired inflation valve location, avoiding direct heat from the exhaust system, radiator, and away from sharp edges, *see Figure "C"*. This should be a protected location, such as under the hood or on the bumper. Do not fold or kink the air line tubing. Insert the air line into the fitting in the air spring. *See Figure "D"*.

Using the supplied nylon ties, secure the tubing to the vehicle. Attach the air line to the A-arm by installing the supplied clip over the existing stud in the A-arm, *see Figure "D"*. Install a 3/8" -16 flanged hex nut onto the stud over the clip. If your vehicle is not equipped with a threaded stud on the A-arm, a 3/8" -16 x 1-1/2" bolt (*not supplied*) can be used.

STEP 6 - INSTALL THE INFLATION VALVE

Drill a 5/16" hole where you wish to mount the inflation valve. Remember to keep the inflation valve in a protected area that is easily accessible. Attach the inflation valve to the bumper or body of the vehicle, *see Figure "E"*.

Cut the excess air line tubing so that it will fit easily into the inflation valve, making sure the end is cut squarely (a "saw" cut with a sharp knife is preferred). Push the end of the tubing into the inflation valve as far as possible.

STEP 7 - INSTALL THE OPPOSITE-SIDE AIR SPRING

Follow Steps 2-6 to install the second air spring on the remaining side of the vehicle.

STEP 8 - COMPLETION

This now completes the installation. Jack the vehicle up and remove the jack stands. Reattach the negative battery cable. Remove the wheel chocks from the rear wheels.

STEP 9 - INFLATE AND TEST

Check the recommended inflation pressure and inflate the air springs to recommended maximum operating pressure (*see page 1 for operating pressures*). With a soap and water solution, check for air leaks around the fittings and valve core. We recommend inflating and deflating in 5 psi increments to find the ideal riding condition for your vehicle.

FOR BEST RIDE use only enough air pressure in the air helper springs to level the vehicle when viewed from the side (front to rear). This amount will vary depending on the load, location of load, condition of existing suspension and personal preference.

*LIMITED WARRANTY FOR
COIL-RITE AIR HELPER SPRINGS AND ACCESSORIES*

Firestone Industrial Products Company warrants that Coil-Rite products will be free from defects in workmanship or materials for a period of 24 months from date of installation. This does not include installation or other service charges for replacement.

For an adjustment under this warranty, contact your dealer or call Firestone.

TO THE EXTENT PERMITTED BY LAW, WE DISCLAIM CONSEQUENTIAL DAMAGES. SOME STATES DO NOT ALLOW THE EXCLUSION OR LIMITATION OF INCIDENTAL OR CONSEQUENTIAL DAMAGES, SO THE ABOVE LIMITATION OR EXCLUSION MAY NOT APPLY TO YOU.

This warranty gives you specific legal rights and you may also have other rights which vary from state to state.

**FOR MORE INFORMATION OR
TECHNICAL ASSISTANCE CALL:
1-800-888-0650**



www.riderite.com